

Sketch-level
Public-Private Partnership (P3)
Service Development Plan

For the Reinstatement of the
Mainstreeter and North Coast Limited | Hiawatha
Route Producing Freight and Passenger Mobility Benefits



Submitted to the
United States Department of Transportation
Federal Railroad Administration, Amtrak Long-Distance Service Study
To Inform Future Study Efforts
October 2, 2023

Contents

Introduction	4
Route Rationale, Goals, and Objectives – Service NEPA Purpose and Need	5
Identification of Alternatives - Service NEPA Alternatives Considered	6
Regional Jet and Hub-to-Hub Jet Service	6
Interstate Highway - Private Vehicles	9
Highway Trip-Time Competitive National Network Rail Passenger Routes.....	9
Average Highway Speeds - Trip Length, Rest, and Time of Day Influences	10
The Importance of a Person’s Trip Length	11
Autonomous Intercity Automobiles.....	12
Effect of Fixed Price Automobile Insurance	13
The Dwight D. Eisenhower National System of Interstate and Defense Highway’s Inherent Leveraging.....	13
Pre-Interstate Legacy Toll Highways are now Hybrid Facilities	15
Future Interstate Highway Investment Needs Projected to Increase Greatly.....	16
Incrementally Alternatives to Interstate Highways	16
Correcting for Highway Trust Fund Leverage with a Simple BCA Metric.....	18
Interstate Highway - Motorcoach	20
Motorcoach Uses in a Coordinated Ground Common Carrier Network.....	22
Corridor Rail Single-service train – With Public Below-the-Rail Infrastructure Coverage	23
Congested Urban Corridor Passenger Rail and Toll Road Infrastructure Investment Models	23
Long-Distance Rail Multi-service train – With Public Below-the-Rail Infrastructure Coverage.....	28
Optimal Size of Intercity Rail Consist:	28
Expanding Intercity Rail Service Types with Product Differentiation	30
Planning Methodology	33
Consider Lessons from the Historical Service Operation and Routing	33
Consider FRA Amtrak Daily Long-Distance Study Routing	35
Improvements to the Origin and Destination Models.....	36
National Parks – Destinations and Onward Journeys	36
Demand and Revenue Forecasts	38
Vehicle Travel Time Savings (VTTS) - Time-Saved Analysis	38
Total Trip - Time-Utility Analysis - Fits Real Traveler Choices	38
Reduced Access Cost Toward and Within Stations.....	40
Operations Analysis	42
Attributes of a Fixed Investment Operator.....	42

Attributes of a Variable Investment Public-Private Partnership (P3) Operator 44

Interstate Competitive Corridor Capacity (ICCC) Public Private Partnership (P3) Governance Structure..... 45

Proposed Reinstated North Coast Limited/Hiawatha – Train Consist, Capacity, and Type..... 48

Proposed Reinstated North Coast Limited/Hiawatha – Operations..... 49

Station and Access Analysis 53

Terminal and Shared Intermediate Stations and Daily Servicing Yards..... 53

Conceptual Terminal and Shared Intermediate Stations and Servicing Yards – Financial Plan..... 53

Intermediate Stations – Route 53

Conceptual Intermediate Route Stations – Financial Plan..... 55

Below-the-Rail Infrastructure - Conceptual Engineering, Capital, Operations, and Maintenance 56

Proposed Railway Infrastructure Investment Rate Equal to Rural Interstate Highways 56

Interstate Highway Cash Flow Analysis used to Calculate Equivalents per Train-Mile 57

Improved Rail Freight Operations on Shared Use Corridor 59

 Domestic Intermodal Rail Freight - Container and Trailer-load Operations..... 61

 Route Characteristics 63

Conceptual Below-the-Rail Route - Financial Plan..... 63

Above-the-Rail Vehicles – Procurement, Capital, Operations, and Maintenance 65

 Private Operator is At-risk for Timely Vehicle Service Entry Allowing for Minimal Reviews..... 65

General Passenger Equipment Improvements 65

 Proposed New Coach Service Equipment for Reinvestment 65

 Why Overnight Rail Travel Works - Reimagining Overnight Service Objectives..... 68

 Proposed New Sleeping Service Equipment for Reinvestment: 69

 Food and Beverage – Multifunction Lounge and Diner Spaces 72

Express Freight Revenue and Traffic Design 74

 Standard Shipping Pallet Based Express Traffic 76

 Standard Truck Trailer Based Express Traffic..... 77

Locomotive Configurations and Fuel Types 79

Conceptual Above-the-Rail Route - Financial Plan 80

Economic Public Benefits Analysis..... 81

 BCA Highway Net Incremental Capital and O&M Metric 81

 Benefits to Rail Passengers 81

 Transport Emissions Reductions 87

 Benefit to Cost Analysis Summary 88

Next Steps in the FRA led Amtrak Long-Distance Service Study 89

Appendix..... 89

Introduction

This Sketch-level Public-Private Partnership (P3) Service Development Plan (SDP) is a conceptual demonstration of the Operational Feasibility, Financial Feasibility, and Value and Merit of a proposed reinstatement of the *North Coast Limited* and *Mainstreeter* service, providing twice-daily service in each direction prior to 1971, or the *North Coast Hiawatha* service operated by the Congressionally funded National Railroad Passenger Corporation (NRPC) doing business as Amtrak until 1979. Particulars of the routes, schedules, maps, and results from earlier proposals are reproduced from publicly funded NRPC¹ or Montana Department of Transportation (MDT)² studies only to serve as a research baseline for this private paper. No endorsement of this report by the NRPC, MDT, other agencies, or the shareholder owned host railroads whose infrastructure over which the route would operate is implied, though the intent is that the proposal provides is a beneficial solution for all parties.

The national level policy purpose of this report is to demonstrate, by means of a worked sketch-level example for this route which may be the most challenging one selected to proceed, how the Federal Railroad Administration (FRA) led Amtrak Daily Long-Distance study may progress in future phases. To do so long-distance passenger rail service is analyzed in the context of the broader aviation program and Surface Transportation Program (STP) financial funding and economic analysis methods. In this analysis a novel parallel type of implementation strategy, using a Public-Private Partnership (P3) as employed as for other modes instead of the series type review-approval programs seen in public led passenger rail projects, is developed to the point of obtaining general results for legislative consideration.

The regional level goal of this work is to serve as a guide for the development of a complete SDP for this route that would hasten new fuel-efficient service, supporting the communities in the interior of the nation. The economic benefits to local communities from a smaller leading federal investment have been sketched out by the Rail Passengers Association³ and the Big Sky Passenger Rail Authority. These economic benefits could be had through the provision of a restored passenger service subject to continuous improvement from a consumer responsive revenue feedback loop as well as improved rail freight service to those same areas, building industry and stable economies as a public good.

The P3 structure proposed in this work builds upon the separation of Above-the-Rail Vehicle Operators and Below-the-Rail Infrastructure Operators that is the goal of competition measures in European democracies where already consumer benefits through better and more expansive service at lower prices are arriving. Yet even though such divisions have existed for some time they are still being practically worked out, led by ALLRAIL EU's efforts, whose contributions to this work are appreciated. The challenge of translating this approach to the United States context is ensuring the proposed public investment metrics allow for infrastructure to remain under the same ownership, with the same integrated freight franchise, while encouraging publicly beneficial improved freight and passenger rail operations supported by better infrastructure. I trust that this proposal will be found to be mutually beneficial for all parties.

Virgil G. Payne, PE

Virgil G. Payne is a professional engineer supporting industry reliant on both highway and railway logistics - where fixed and variable cost functions must be understood. Previously he supported his state DOT coordinating mostly highway projects, such as I-269 from planning to construction. This work followed a period of designing infill buildings, sites, and utilities and a brief stint in railroad operations, yielding a perspective from both sides of the fence on customer needs and transportation projects. The position taken is entirely his own as a call to begin talking consistently about financial costs in order to provide reform to the surface transportation system design and funding mechanism for true resource efficiency and hasten implementation through innovative project structures.

¹ Amtrak, P.R.I.I.A. Section 224 North Coast Hiawatha Study Plan, 2009

² Montana Department of Transportation, 2010 Montana State Rail Plan and Feasibility Report on 2010 Proposed Amtrak Services in Southern Montana, < <https://www.mdt.mt.gov/publications/docs/brochures/railways/amtrak-railstudy.pdf>>

³ North Coast Hiawatha Restoration: A Solid Return for Taxpayers and Business, September 2021, Rail Passengers Association Research Note, <https://narprail.org/site/assets/files/5819/v3_final_north_coast_hiawatha_restoration_a_solid_return_for_taxpayers_and_business_1.pdf>

Route Rationale, Goals, and Objectives – Service NEPA Purpose and Need

Travel Corridors the Study Route is Proposed to Serve

The proposed route is primarily along an East-West corridor between Chicago, IL and Seattle, WA serving at the intermediate points the cities in the southern parts of Montana and North Dakota. The route is most logically thought of as a reinstatement of the *North Coast Limited* and *Mainstreeter* service, which provided twice-daily service in each direction prior to 1971, or the *North Coast Hiawatha* service operated by the Congressionally funded National Railroad Passenger Corporation (NRPC) doing business as Amtrak until 1979.

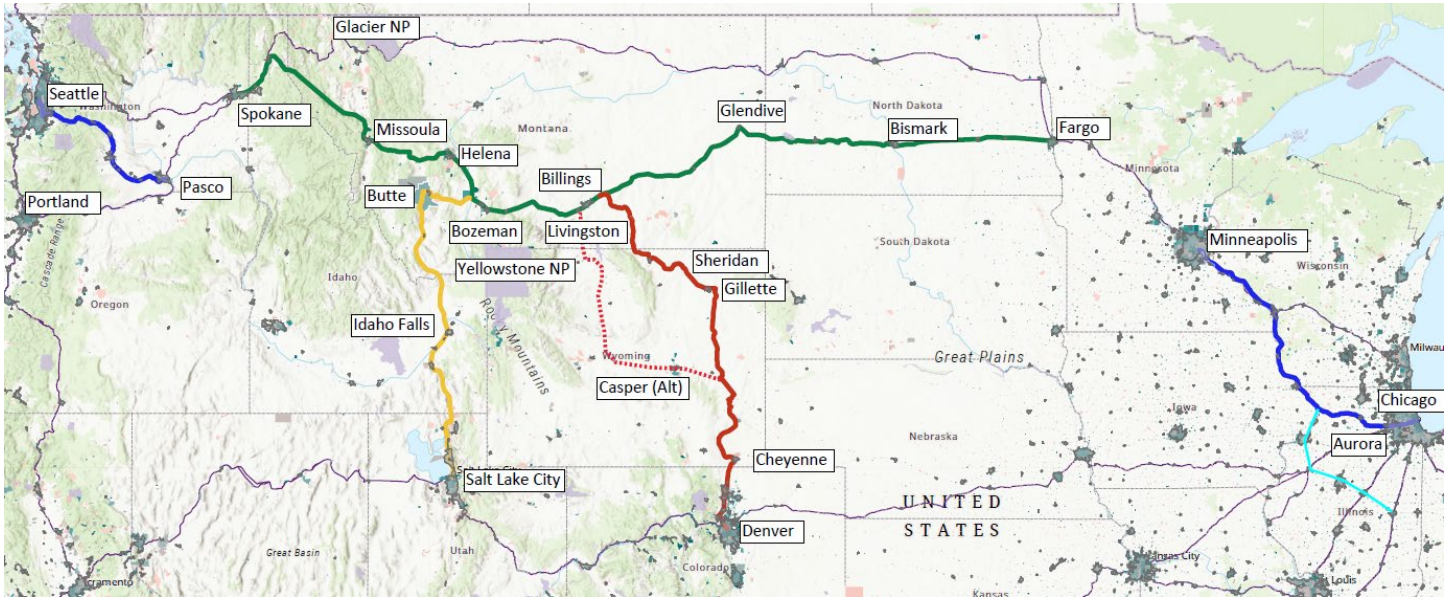

General View of Corridors Considered: Existing Long-Distance Passenger Rail Routes in Thin Purple

- Green: Trunk Route Proposed Minimum Operable Segment (MOS) to Meet Some Objectives
- Blue: Alternative End Terminal Feeder Route
- Red: Denver Feeder Route
- Yellow: Salt Lake City Feeder Route
- Cyan: Major Motorcoach End Feeder Route

Rationale, Goals, and Objectives - National Environmental Policy Act (NEPA) – Proposed Purpose and Need

1. **Improve Intercity transportation service of persons and freight** along the Trunk Route, primarily focused on an underserved band of 200-to-1000 mile trips by persons, often too long to drive efficiently while not long enough to be economically served by commercial aviation, while allowing longer trips to proceed along the Trunk Route.
2. **Advance True Resource Efficiency**, with annual public financial investments equal to or less than those for other modes per person-mile or freight unit-mile transported, so that parallel investments can occur on different modes while reducing uncompensated financial costs of accidents seen by persons.
3. **Support distributed residential, industrial, and agricultural development**, by providing consumer desirable intercity transportation service to smaller cities, inducing skilled persons to desire to reside there and promoting the overall social and economic health of those communities while promoting conservative land development.

The following work seeks to show with reform of the Surface Transportation Program (STP) financial funding mechanisms and economic modeling these objectives can be achieved with the restored intercity rail route by a targeted grant.

Identification of Alternatives - Service NEPA Alternatives Considered

Regional Jet and Hub-to-Hub Jet Service

Commercial aviation has perhaps been provided with the most generous infrastructure investment irrespective of cost recovery as there was no dedicated accounting of airfield costs until the 1970⁴ Airport and Airway Trust Fund, by which time almost all of the main airway infrastructure was in place through conversions of military airfields. Yet still operational cost atop this long established infrastructure is challenged for trips under 1000 air-miles per the chart below.

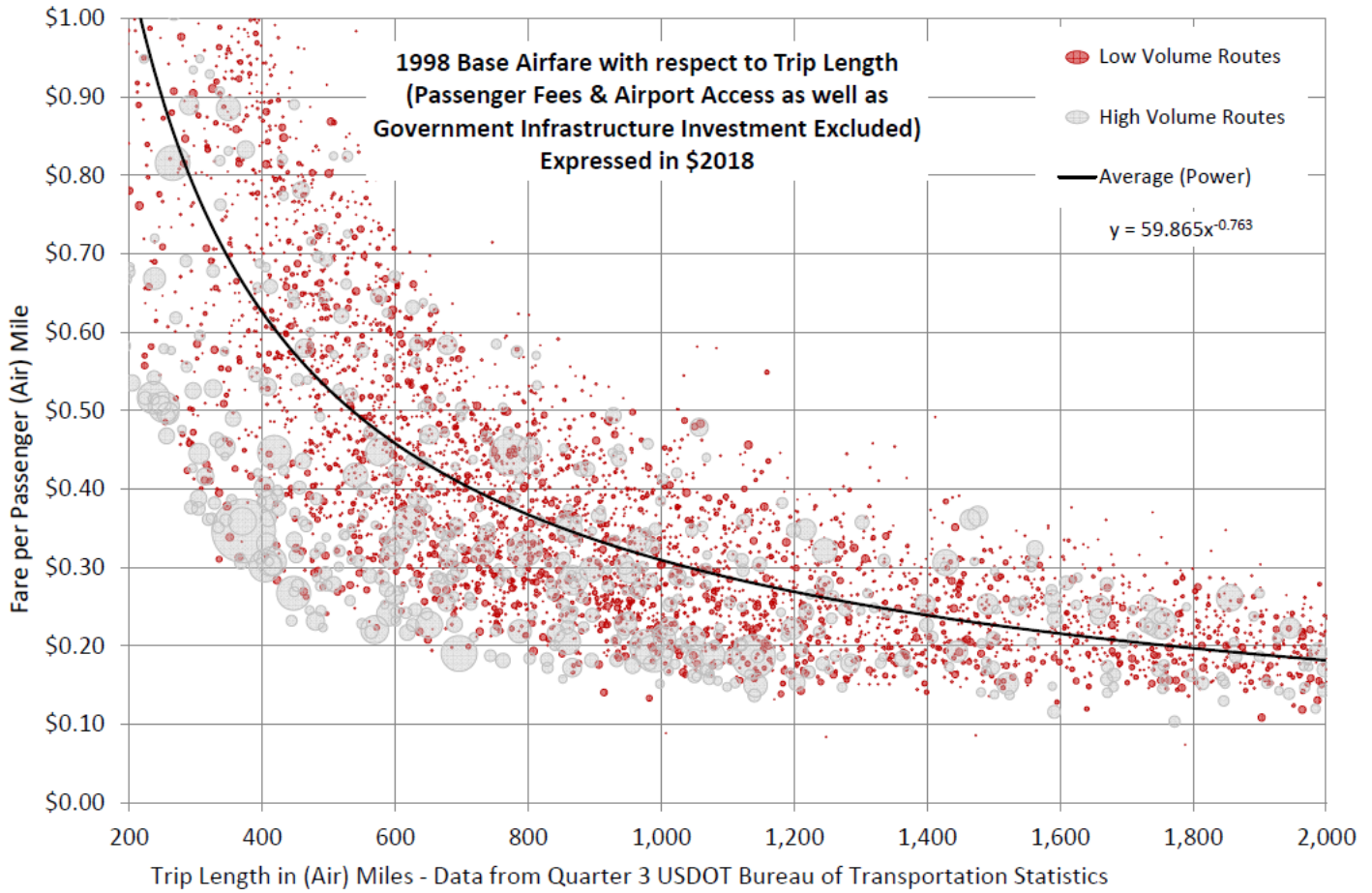

Note that even in the 1998 season of cheap Jet A fuel and new regional jets, illustrated in the 1998 chart above, average ticket prices at a 700 mile trip distance have only changed from around \$0.40 (\$2018) per 1998 passenger mile to \$0.35 per 2018 passenger mile during the route restructurings, but the uncounted costs of additional baggage and change fees, the decreasing size of aircraft seating, and lost time of security screening have perhaps dropped the overall utility of the product in a traveler’s estimation. If one looks carefully the elimination of mini-hub non-stops can be seen between the 1998 and 2018 chart as well as the influence of the one large Intra-California under 400-mile trip airline market.

⁴ FAA. *Budget - Airport & Airway Trust Fund (AATF)*. 2019. <<https://www.faa.gov/about/budget/aatf/>>

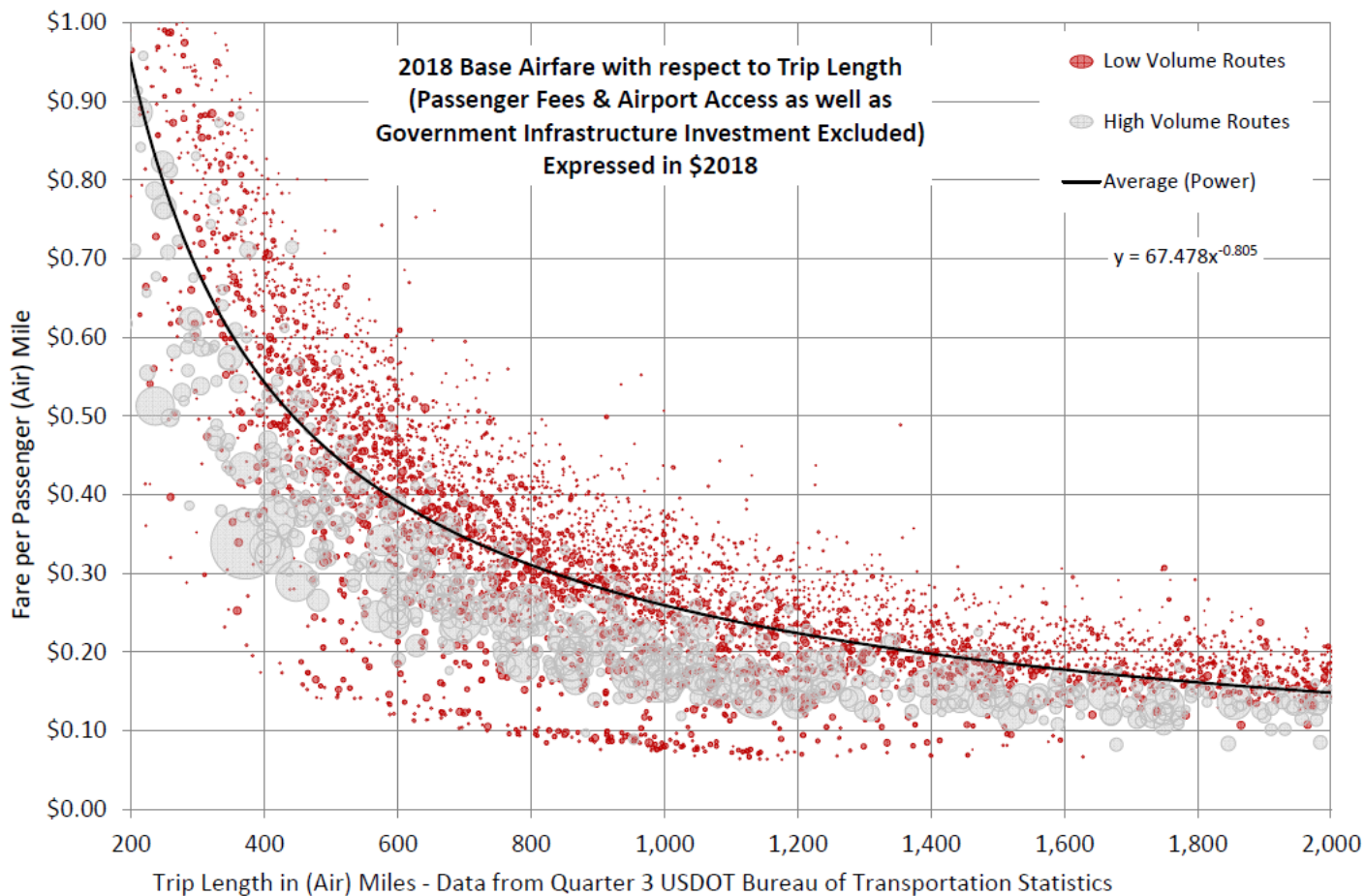

Access time and cost from airports, particularly in large metropolitan areas, combined with the cost curve above, unproductive time, uncertain waiting in hub airport transfers, and the desire to generally arrive in the morning, now limits the utility of regional aviation for shorter trips. It simply appears to no longer be possible to make a same day business trip in the Author’s experience without a direct flight, necessitating at least one hotel night or perhaps two. However, there is an aversion to long-distance highway trips that shows up as a large modal shift away from highways at trip distances approximately that of a full days’ worth of highway driving⁵.

To understand the space between these commercial airfare and long-distance highway driving consumer choice questions for 200-to-1000 mile individual trip lengths, several worked examples using a proposed Time-Utility economic analysis methods are outlined later, including special worked studies under a modified BUILD grant framework using experimental values.

Can commercial air transport function on less than 400-to-600 mile low volume routes with some level of subsidy for the operation of the vehicle? The solution used to be the regional jet, but the pullback due to higher jet fuel prices has been well documented⁶, but even still low stage length is the real challenge for any size aircraft. Despite the large amounts of non-user capital invested prior to 1971 into runways and terminal buildings, operational costs are still too high under current fuel costs. The total trip time for a two-segment flight, when connecting through a hub and spoke terminal, can take 5-7 hours each way, making a same day business trip impossible, but this would only apply to travel between mid-sized cities.

⁵ Schafer, Andreas. "REGULARITIES IN TRAVEL DEMAND: AN INTERNATIONAL PERSPECTIVE." MIT, 2000. <<http://citeseerx.ist.psu.edu/viewdoc/download?doi=10.1.1.454.5721&rep=rep1&type=pdf>>

⁶ Wittman, M. D., & Swelbar, W. S. (2013). Trends and Market Forces Shaping Small Community Air Service in the United States. MIT.

At a 260 mile stage length a CRJ-700, seating 70 passengers gets 27.0 PM/KG at a 78% load factor. At a similar stage length, a E-195 seating 122, gets 33.0 PM/KG, increasing to 48.7 PM/KG at a 675 stage length⁷. However, one must recognize that most of the mid-sized city pairs served by intercity rail would require at least one transfer if flown by air. So the average stage length is going to be half the full trip distance. At a 0.97 energy density ratio for Kerosene Jet A to Gasoline and a 1.4 person average occupancy of a longer intercity automobile journey, the equivalent automobile gasoline mileage would thus be 24.3 MPG for the 260 mile stage length of the larger E-195 regional jet.

However, even after the large amount of non-user capital invested in airport infrastructure prior to 1971, one can see that operationally, only for stage lengths above 650 miles do the financial characteristics of airline travel become acceptable, though comparatively high if more than one traveler is in the party. This range also seems to be comfortably past the airport increased security induced, airline-automobile breakeven rule of “six hour” drive time, 350 miles, that many business travelers use for trips away from congested areas. Given that most flights to medium sized towns will require two segments along with the difference in air and ground miles, the weighted average trip length where it makes sense to seek common carrier alternatives to airlines for those trips below 800 miles.

But there is still the question of if we can expand the airport infrastructure going forward in a financially responsible way. At the 50+ large metro areas it certainly makes sense to use the existing slots for larger aircraft, flying longer stage lengths as this is where they perform well. To the degree that shorter flights can be served by other common carrier modes, substantial financial savings can be had in the system.

The lack of adequate infrastructure capacity – airports and airspace – and the rapidly growing costs of maintaining and expanding this infrastructure are two of the most critical problems for the future of air transportation, nationally and internationally. The prospects for substantial relief on the capacity front are not good – at least in the medium term (next 10 years). While the FAA and other air navigation service providers around the world have been working, with some success, toward increasing the capacity of the en route airspace, the real bottlenecks of the air transportation system are the runway systems of the major commercial airports in North America, Europe and Asia and the terminal airspace around them.

The only clear way to increase the runway system capacity at these airports substantially, i.e., at rates similar to those at which demand is growing, is through the construction of new runways at existing airports or additional airports in the same metropolitan areas. But obtaining approval for and eventually opening additional runways and new airports is an extremely difficult and time-consuming proposition in most developed countries. Barring these, airports and national civil aviation authorities may have to resort to increasingly stringent “demand management” measures, such as slot restrictions, congestion pricing, and even the auctioning of access to major airports.⁸

⁷ Owner's & Operator's Guide: E-Jet Family. (2009, June/July). Aircraft Commerce

⁸ MIT-GAIP website, 2013, <<https://dspace.mit.edu/handle/1721.1/34280>>

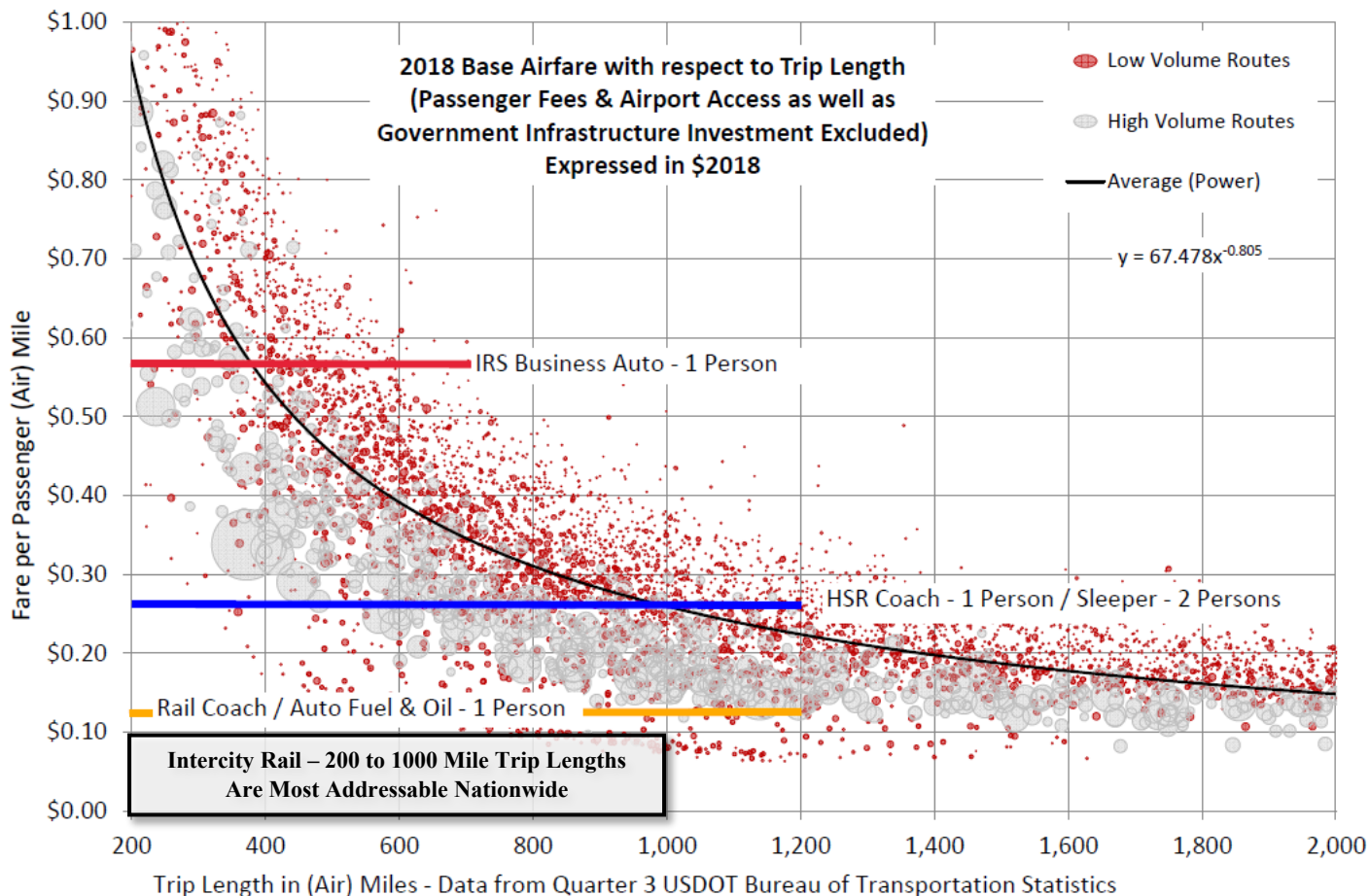

A combined ground network consisting of up to a 100 mile automobile trip on one end combined with an overnight passenger train can outperform regional airline travel when considering the total trip cost including lodging for many individual trip lengths less than 800 miles, or even trips up to 1000 air-miles that require an airport hub connection. This is due to the price curve (nearly representative of a cost curve in a competitive market with low barriers where governments own all the infrastructure) which has strongly increasing average per-mile values below 1000 air-mile trip lengths.

Conclusion

For the purpose of Identification of Alternatives since additional capital for airport construction would be required to support the demands for landing space from smaller regional jets at a much higher rate than seen currently and the operation of regional jets serving local markets has already peaked and vastly pulled back as fuel costs have increased, further expansion of service for this alternative beyond the current operations is removed from consideration.

Interstate Highway - Private Vehicles

Highway Trip-Time Competitive National Network Rail Passenger Routes

Due to the inherent leveraging of highway infrastructure from taxes on the use of locally financed streets, travel by the Interstate Highway system is the intercity travel option that occupies the largest modal share of intercity trips in the United States. Hence it is reasonable to compare actual trip times by highway to those offered for trips under the apparent 1000 air-mile pricing breakpoint noted later for commercial aviation. Amtrak by statute is to consider benchmarking their service provisions against intercity trip times such as the highway trip curves below that include rest and meal stops, yet has largely ignored the overlapping trip options on through running National Network rail passenger

routes, particularly comparisons against long distance driving for departures at the end of the day after productive time at the destination.

Average Highway Speeds - Trip Length, Rest, and Time of Day Influences

While overall trip times are important, even individual trip lengths over 200 miles not terminating in a large metropolitan area can be highly competitive for intercity passenger rail due to the “lost-time” factor of spending too much unproductive time driving which the Time-Utility methods explores. However, to do so train stations need to embrace efficient automobile rental and parking options that are linked to the ticket. Such links broadly fit within the push for Mobility-as-a-Service (MaaS) many automakers are pursuing as a future market.

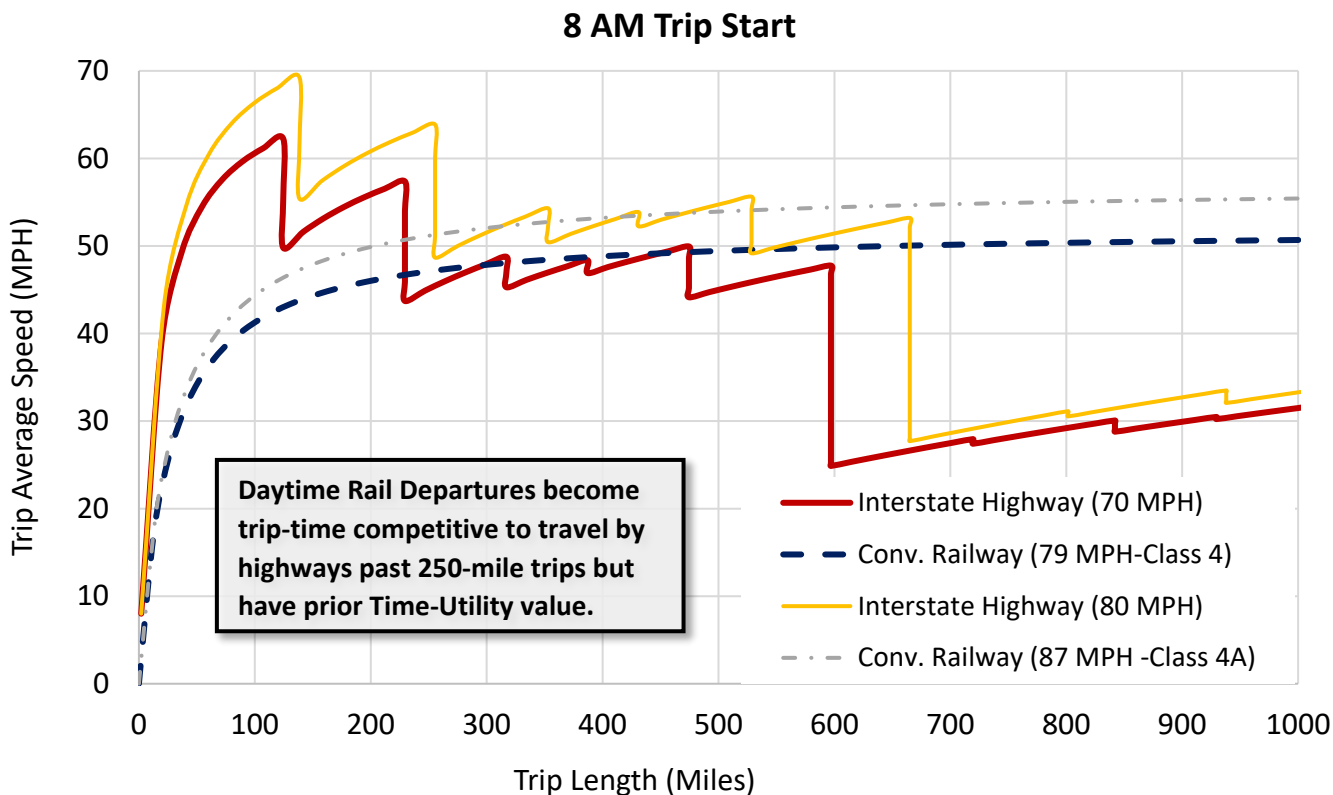

For this route a daytime ability to use MDT 80 MPH Interstate Highways⁹ is compared with either existing Class 4 79 MPH passenger train speeds and a conceptual Class 4A 87 MPH middle-ground before the Class 5 90 MPH track standards. With the use of Positive Train Control (PTC) the limiting consideration for higher speeds shifts to the track maintenance tolerances which correlate to the square of the speed. Conceptually 87 MPH / 140 KPH would fit within existing track maintenance standards, providing an economical 10 % speed boost relative to Class 4 track standards.

The intent would be to explore if this higher speed option could be used on the middle daytime segment with a slower operational speed overnight.

⁹ MDT Interstate Highways have Automobile speed limits of 80 MPH, < <https://www.mdt.mt.gov/visionzero/roads/speed-limits.aspx>>

4 PM Trip Start

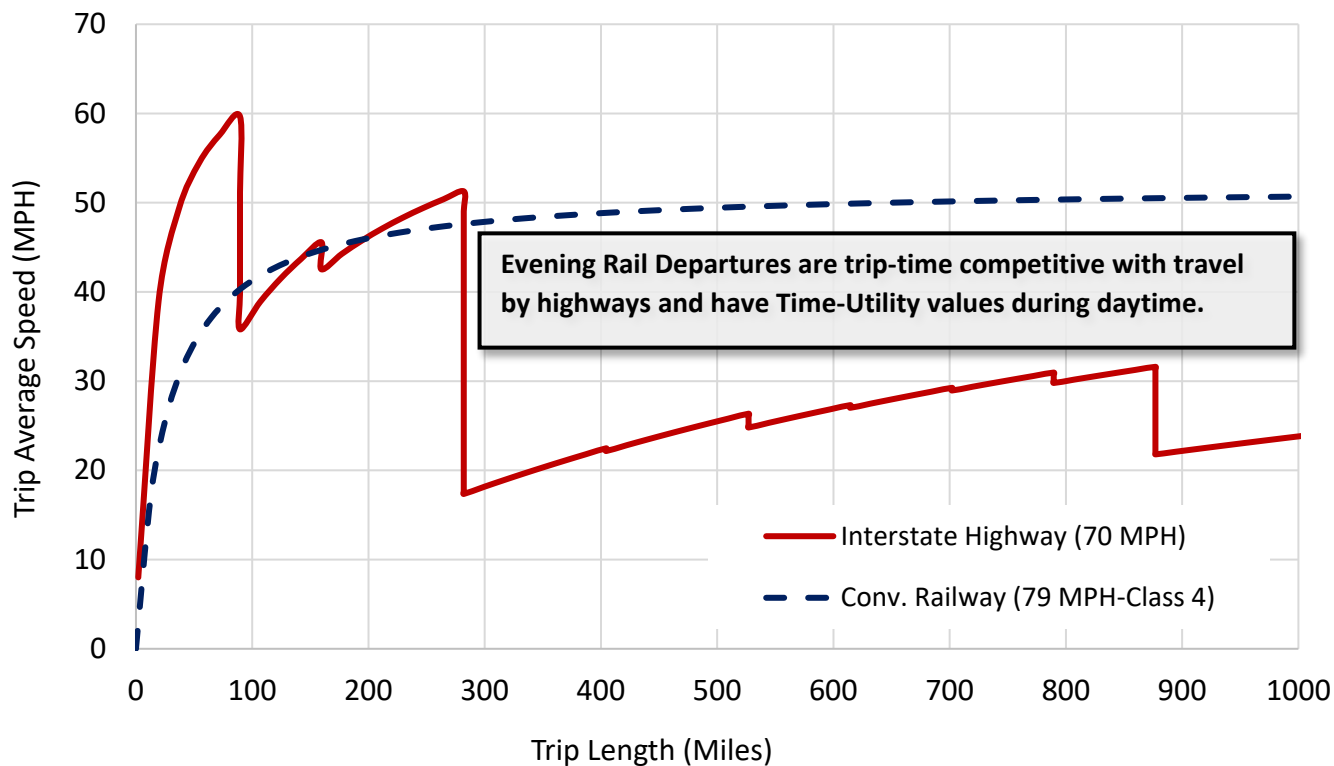

From the two charts it can be seen that in a geography with relatively less congestion and unpriced parking it is likely that intercity trips will not become purely trip-time competitive until the individual’s trip length reaches around 250 miles, however from the consumer’s standpoint productive use of time not dedicated to driving is likely had for trips that require at least one intermediate rest stop while driving which would be about 140 miles. As a rough screening benchmark, 200 miles is a logical starting point for non-repetitive intercity trips outside congestion regions where parking is not priced. Later in the aviation analysis the question of an upper bound for trip length by individuals is considered.

The Importance of a Person’s Trip Length

Commonly the total vehicle miles traveled on all roads is cited as a comparison to common carrier’s share of the marketplace. However, one must recognize that very few long automobile trips are taken on the interstate network as a percentage of total trips, and consequently vehicle miles. Around 2/3rds of all private automobile vehicle-miles operated on the Interstate Highways are actually daily commuting miles which skews intercity analysis if one doesn’t account for these trips. The new six-hour (350 mile) air-drive breakeven seems to hold from the chart below, but there is still demand for longer trips. Within the Economic Benefit to Cost section additional models dealing with this trip time question are proposed.

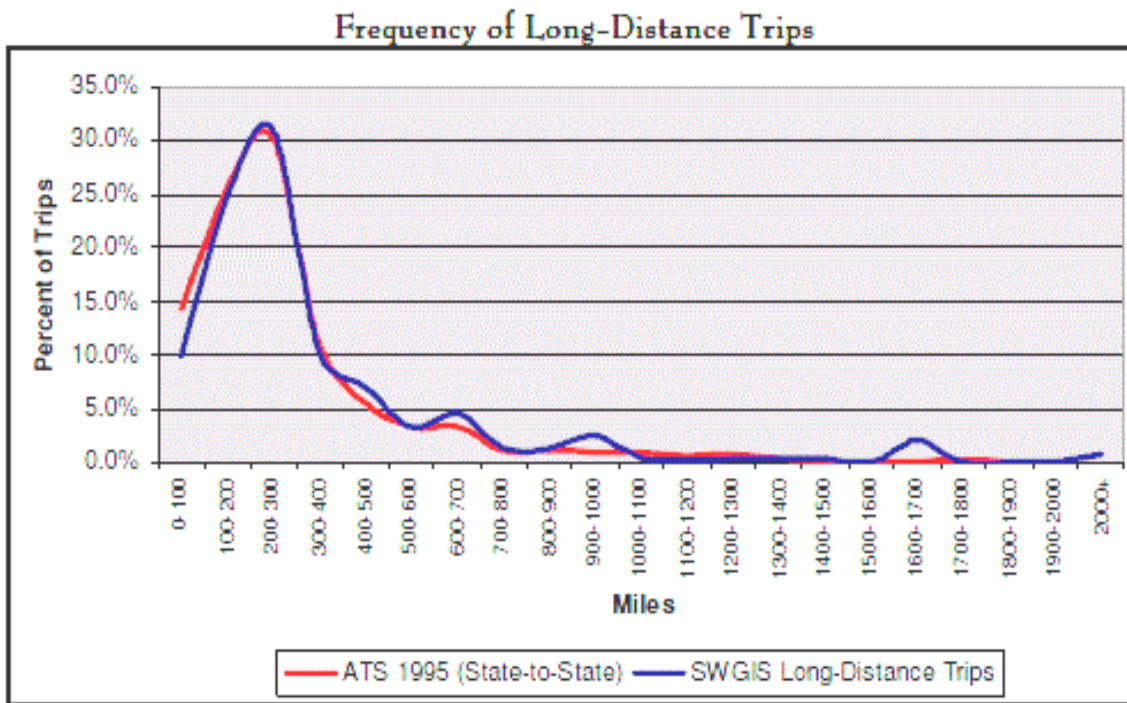

Reproduction of South Georgia Interstate study chart¹⁰

Autonomous Intercity Automobiles

Recently, there has been a push to suggest that autonomous automobiles might just be the solution to bringing the interstates up to modern standards of safety as thought the technology is a near term option. Winston recently made a claim that such a move could be used to reduce urban congestion by allowing for the narrowing of lane widths and hence more lanes on the same Right of Way. However, such a proposal does not recognize the financial cost of building a new dedicated lane structure for such an operation, as there would surely have to be a reservation against general traffic.

Some have suggested such automobiles could function out in rural areas on existing shared interstate routes. But a robot car won't stop a running deer coming through the windshield at 70 mph as happened to the author or dodge objects falling out of a trailer ahead. Sometimes it is just outside of the laws of physics to maneuver to avoid such random occasions. And of course, there will still be the people who want to go faster than the speed limit so they will be piloting their own cars treating the robots like road cones.

In a darker view, perhaps teenagers would play a game where they harass those in robot cars by pulling in front of them and forcing the robot car to slow down multiple times till the driver intervened and retaliated. After all we do live in a society where a portion of the population view insurance accident scams as a viable means of income, with little remorse for the risk.

For long distance commuting, the whole autonomous concept sounds intriguing. Perhaps one could check office emails on the way to work. But this idea is tempered with the fact that congestion will just go up as the time use disincentive is removed. People will simply attempt to live even further out with a greater burden to supply road capacity to those users who are already underpaying by a variable measure. This shift would work for the early adopters using existing roadways if automation can be trusted; until such a time as large-scale use might occur at which time new traffic congestion patterns would likely develop. More than likely a wave of start stop congestion would develop down the roadway, shortly after the point where drivers took the automobiles off automatic control and entered the passing lane

¹⁰ GDOT Southwest Georgia Interstate Study - Technical Memorandum Development of Travel Demand Model. PBS&J., 2009

once the rightmost lanes become congested. With no financial mechanism to afford any expansion the extra drivers would be trapped far from business centers as this effect developed over time.

However, the reality of the automobile is that all liability is ultimately assumed by the user. The main financial advantage to automobiles is that you don't count the costs of your own mistakes, perhaps through a lack of humility, but when they become a courtroom decided liability no corporation will take on the risk in the analysis of this author unless they are getting \$0.15-0.20/VM or more in compensation. The author does not see that being a valid financial model as other options become cheaper.

Effect of Fixed Price Automobile Insurance

The conceptual problem in a society wide financial analysis is insurance is assumed to be constant per year in the AAA analysis above and in consumers decisions. This is of course how the current markets are set up in many instances, but insurance is a proxy for risk, which is highly correlated to the VM traveled. For a larger financial system, without controlling for this effect, the market can get to the point where the yearly entry point to driving is unaffordable.

This explains the difficulty encountered by governments in dealing with the problem of un-insured motorists. At the lower end of the employment scale, requiring and individual by law to buy automobile insurance, when free cash is tight, sets up governments to deny access to practical employment within the system that has been created or asking them to give up some consumer good. Clearly, some form of pay-at-the pump liability insurance would be preferable, but we also want to keep consumer fuel prices low.

To a degree automobile insurance offers some discounts on a self-reported mileage basis. But one is not expected to actually pay extra per mile prior to a trip or ever once the higher mileage bracket is entered. Further, automobile insurance only pays a portion of total accident costs, particularly when a severe accident happens. Any Personal Injury lawyer will tell that a mixture of Automobile as well as Private and Public Health, Disability, and Life Insurance pays out in a severe accident.

The author could not get a quote for more than \$100,000 of medical coverage on his automobile policy, which would not be sufficient in severe accident. Since Common Carrier ground travel is up to 16 times as safe¹¹ as Intercity Automobile travel per passenger mile some financial accrument to society would occur in a marginal shift to the safer ground modes of intercity rail and bus. Whether this is a financial or economic savings is an open question. To an automobile insurance company, one's decision to take a common carrier instead of driving is a financial savings but to the one paying the fare it is a financial cost.

The Dwight D. Eisenhower National System of Interstate and Defense Highway's Inherent Leveraging

The funding of infrastructure investment in what many view to be the default travel option, the Interstate Highways, has always been a slippery concept. Generally, a broad federal level excise "gas" tax was placed on the existing use of a vast network of greater than 3.3 million miles of existing local streets, neighborhood lanes, and city boulevards, which are largely locally funded through city taxes or constructed with private property development mortgages. It would be like taxing food purchases at all cafes, coffee houses, convenience stores, groceries, and restaurants to build a new restaurant, offering an inexpensive buffet, while just painting the walls elsewhere with the funds. Such a scheme could obliquely be called a "food user fee" for "food infrastructure yet it obviously tilts the market. Then formulaic programs direct the funds largely to only limited access intercity highways or wide suburban arterials. The very high publicly funded financial gap between incremental fuel excise tax and fee revenue and the financial costs of construction, maintenance, and accidents upon such Interstate Highways is generally not seen by the users for this reason.

¹¹ National Safety Council, Injury Facts, 2011

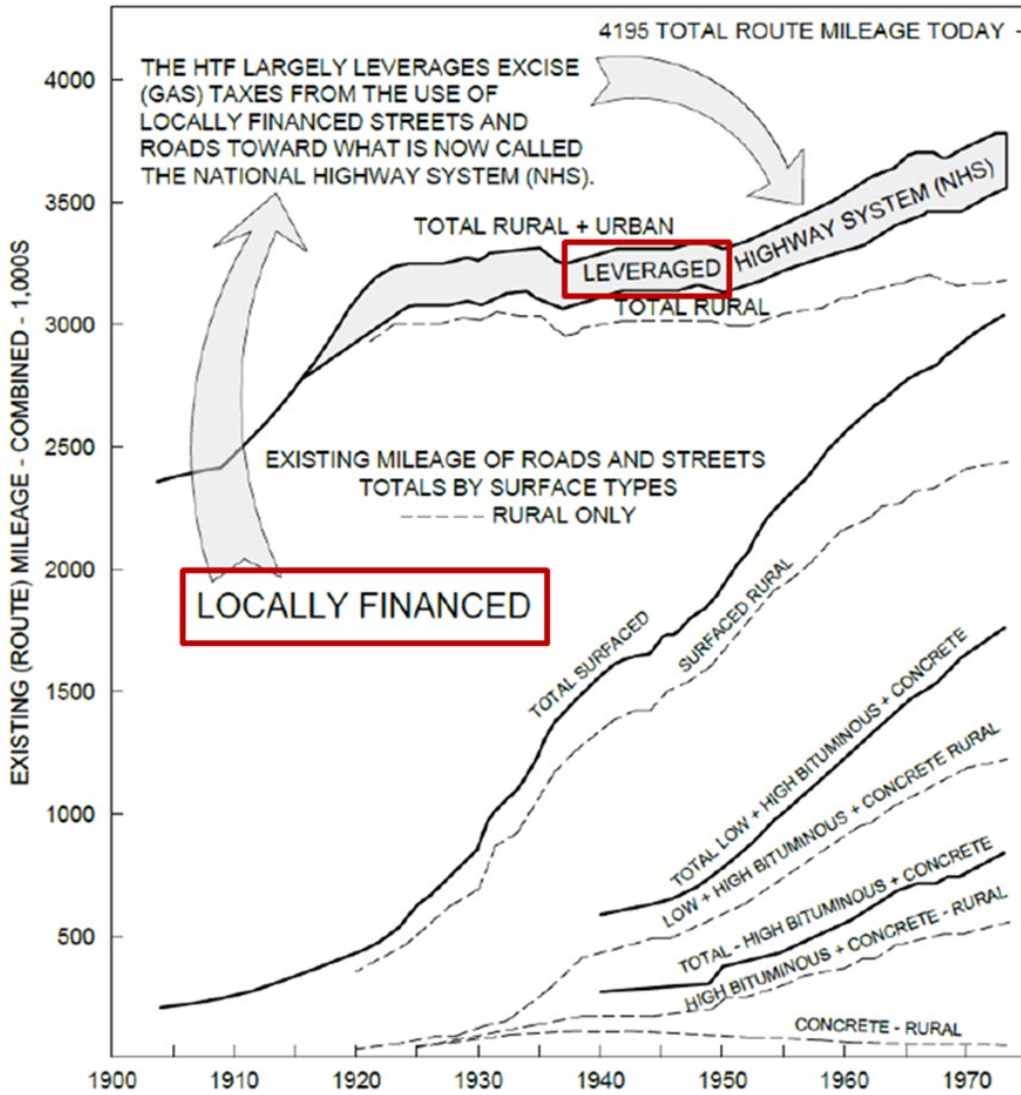

Chart of Historical Sources for Leveraging by Gas Tax on Use of Existing Roads – Author

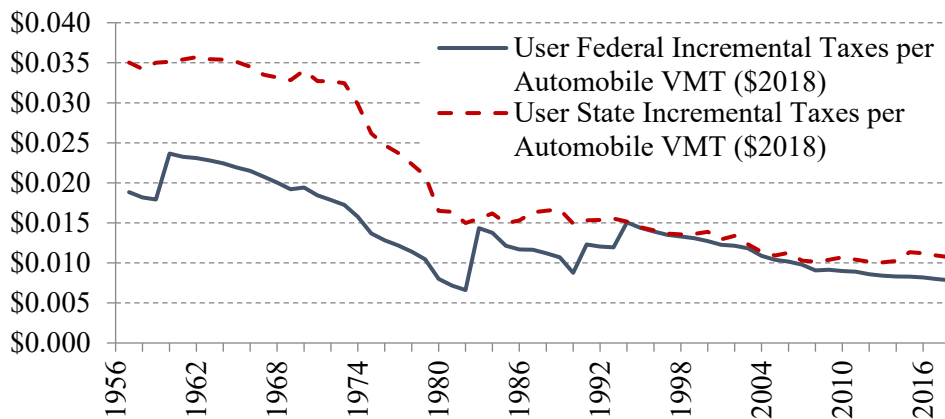

Chart of Incremental Gas Tax Federal and Average of 50-States Gas Tax Revenue per Mile Traveled – Author

Pre-Interstate Legacy Toll Highways are now Hybrid Facilities

For the pre-1956 legacy toll routes it must be remembered that States were reimbursed for some of the original cost and future 4R capital maintenance through the 1991 ISTEA¹², so that they are in effect now operating as a hybrid facility as part of the cost-sharing premise of ISTEA, though from a fixed pot of funds. Even the Pennsylvania Turnpike, the earliest facility of the main east-west chain cutting through the Appalachian Mountains, benefited from direct grants of 40%¹³ of costs through Depression era funding as well as government risk assumption on the remaining borrowing. However, with the nationwide marketplace expectation for user payments on highways set so low, by six-decades of practice, one has to conclude that adding large scale tolling would not gain political acceptance in the United States outside of bottleneck urban areas.

Toll Facility	Facility Length (miles)	2-Axle Vehicles		Effective Truck Multiplier			
		Full-Length Toll		Toll per Mile		5-Axle Truck	
		ETC	Cash	ETC	Cash	ETC	Cash
Indiana Toll Road	157	\$10.75	\$10.70	\$0.07	\$0.07	4.0	4.0
Kansas Turnpike	236	\$10.60	\$13.75	\$0.04	\$0.06	3.0	2.6
West Virginia Turnpike	88	\$3.90	\$6.00	\$0.04	\$0.07	4.2	3.4
Ohio Turnpike	241	\$12.75	\$18.75	\$0.05	\$0.08	3.1	2.7
Oklahoma Turnpike	477	\$29.55	\$32.80	\$0.06	\$0.07	3.5	3.4
Will Rogers Turnpike	87	\$4.50	\$4.75	\$0.05	\$0.05	4.0	4.0
Turner Turnpike	86	\$7.15	\$7.65	\$0.08	\$0.09	0.0	0.0
Cimarron Turnpike	59	\$3.30	\$3.75	\$0.06	\$0.06	3.8	3.5
Indian Nation Turnpike	105	\$6.20	\$7.00	\$0.06	\$0.07	3.2	3.0
HE Bailey Turnpike	86	\$5.10	\$6.15	\$0.06	\$0.07	3.0	3.0
Muskogee Turnpike	53	\$3.30	\$3.50	\$0.06	\$0.07	3.1	3.1
Illinois Toll Roads	640	\$53.08	\$83.95	\$0.08	\$0.13	6.1	4.8
Jane Addams Memorial Tollway (I-90)	76	\$3.95	\$7.90	\$0.05	\$0.10	8.7	4.3
Reagan Memorial Tollway (I-88)	96	\$5.10	\$10.20	\$0.05	\$0.11	8.6	4.3
Tri-State Tollway (I-94/I-294/I-80)	78	\$3.20	\$6.40	\$0.04	\$0.08	8.6	4.3
Veterans Memorial Tollway (I-355)	33	\$3.80	\$7.60	\$0.12	\$0.23	6.9	3.4
Pennsylvania Turnpike	360	\$37.03	\$51.85	\$0.10	\$0.15	5.2	5.2
Northeast Extension	110	\$10.16	\$15.00	\$0.09	\$0.14	5.8	5.5

Chart¹⁴ of 2018 Toll Rates on Legacy Toll Highway Facilities (Now Only Partially Revenue Funded)

It is instead intended that a hybrid bridge between leveraged public investments and shareholder led operations can be mediated by the historic investment rate found for interstate highways as congestion increases in urban areas prior to a future full market restoration of urban land prices and parking rates. For some time the investments structure could follow the arrangement shown with a certain average cost public investment, atop which project sponsors either structure operations to generate enough revenue or come to an agreement for a private developer, state, or local

¹² US. "Public Law No: 102-240 Intermodal Surface Transportation Efficiency Act, Section 1012 Toll Roads Bridges and Tunnels (4R IM funds) & Section 1014 Reimbursement for Segments of the Interstate System Constructed without Federal Assistance (Legacy Pre-1956 Toll roads)." 1991. <<https://www.govinfo.gov/content/pkg/STATUTE-105/pdf/STATUTE-105-Pg1914.pdf>>

¹³ US Secretary of Commerce. "Progress and Feasibility of Toll Roads and Their Relation to the Federal-Aid Program." 1955.

¹⁴ MNDOT. "Minnesota Tolling Study Report Modern Tolling Practices and Policy Considerations." 2018. <<https://www.dot.state.mn.us/govrel/reports/2018/tolling-study-report.pdf>>

contribution for certain projects that need innovative Design Build approaches with risk management. However, all other highway projects would use a metric derived from the study of public Interstate Highway investment as a reformed HTF for their funding source, inevitably filled with non-fuel tax General Fund dollars for political reasons.

Future Interstate Highway Investment Needs Projected to Increase Greatly

Studies from 2019 on the future needs by the National Academies have pointed out the inflection point at which we have arrived. Even after the \$141 Billion additional investment, the Interstate highway network is falling behind in its ability to provide today's level of service into the future. Estimates of around an additional \$36 Billion¹⁵ annually of investment over a period of twenty years have been sketched out to meet just population growth levels of additional travel, though around a half of the vehicle miles traveled on the system are in fact commuter trips, not interstate trips.

Conceptually, this study also demonstrates that future Interstate Highway congestion will spread beyond urban corridors, stretching far into rural areas. A true twenty-year plan from the USDOT should consider the question of a citizen's ability to choose a different option to long-distance driving. These needed investments would increase the historical highway revenue gap by about a nickel a mile, to about eighteen cents per rural automobile mile traveled but perhaps new alignments should be separated from the averages to explore how investment rates that are two to three times the average rate, around forty cents per automobile mile traveled, can fit the needs of citizens in congested regions.

However, of late funding is shifting further still to direct Federal General Fund transfers. The general misunderstanding of this leveraged highway cost gap and the political messaging of "user fees" paying for all is why toll highway facilities seem rather overpriced relative to public expectations when proposed. Of course, we need widespread and dependable investment in all infrastructure for national connectedness.

This political challenge of declining real (inflation and fuel economy adjusted) incremental highway fuel tax revenue is fraught as the flow of Federal General Funds into the HTF becomes more challenging to provide.

Incrementally Alternatives to Interstate Highways

For six decades it has been understood that all mobility needs cannot be met by highways, but a steady financial funding mechanism has not been put in place perhaps due to a lack of understanding of Highway Trust Fund leveraging, where toll roads are essentially an occasional solution to a limited bottleneck. We now have the experience to see the need for sustained dual investment program.

These program changes would allow for railway investments to occur in parallel to highway investments, in small incremental steps so as to improve the network gradually in a more efficient manner where engineers could plan for multi-year projects. The need for such a dual approach was known around and shortly after the 1956 Interstate bill, as President Eisenhower who had called for the Interstate Highways funding to be "self-liquidating... through the assured increase in gas taxes"¹⁶, appointed General Bragdon to a Study Committee¹⁷ on city mobility and urban highways. The full report questioning urban highway applications was not issued in 1960 due to lobbying supporting a highway only solution.

Certainty in investment would serve to redevelop links to the potential of the heartland of the country, supporting prosperity by distributing opportunity to the interior cities that citizens there might be engaged more effectively in the wider economy for our joint prosperity.

¹⁵ The National Academies of Sciences Engineering Medicine. "Renewing the National Commitment to the Interstate Highway System: A Foundation for the Future." PG 158, 2019. <<https://www.nap.edu/download/25334>>

¹⁶ FHWA. Ike's Grand Plan - Notes from President Eisenhower's 1954 Governor's Conference Speech. n.d. <<https://www.fhwa.dot.gov/infrastructure/50grandplan.cfm>>.

¹⁷ Mertz, Lee. The Bragdon Committee - Highway History. n.d. <<https://www.fhwa.dot.gov/infrastructure/bragdon.cfm>>.

For this reason the grant would be funded at an equivalent level to the Interstate Highway System’s true cash-flow derived six-decade-average consumer cost gap¹⁸ (the difference between pro-rated fuel taxes and Long-Run financial cost - hidden by leverage) so as to allow for those entities operating trains in the corridor, host railroads for freight and a competitive passenger operator, to provide consumer responsive service to a greater volume of traffic competitively while highway renewal continues in parallel.

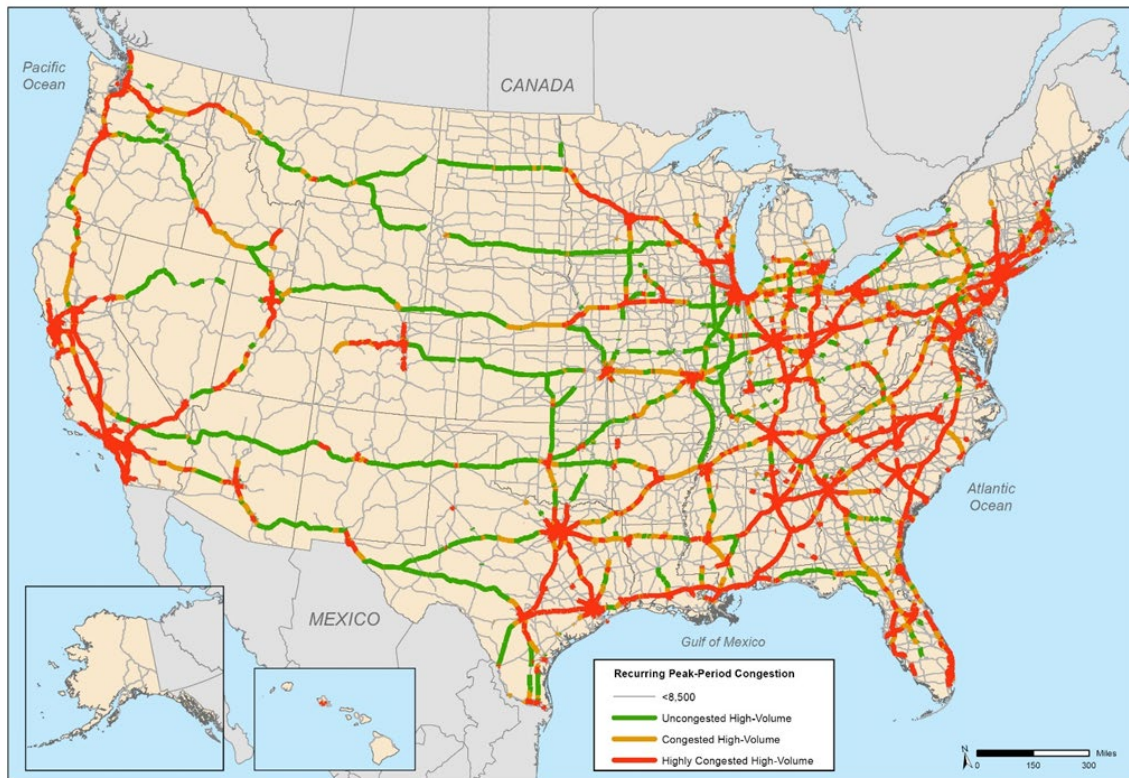

Peak-Period Congestion on High-Volume Truck Portions of the NHS: 2040 FHWA National Statistics and Maps



Rural Interstate Highway Backup – Author

¹⁸ Payne, Virgil, "Reforming Surface Transportation for Long-Term Sustainability", Competitive Enterprise Institute, Issue Analysis 2020 No. 10, November 2020. <https://cei.org/news_releases/report-urges-reforming-surface-transportation-for-long-term-sustainability/>



I-80 Multiple Truck Involved Wreck, 2021

Equal Citizen Accessibility in Federal Programs

Within Federal transportation planning there does need to be a consideration of equal access to funding. Consider the example of the grandparents who have spent many years of their life in a community, building a business, donating, educating, and contributing to the development of the wealth of the city's tax base that largely finances local infrastructure. Currently, the Federal government is providing somewhat stable funding in most instances only for the highway option from an excise (gas) tax on the use of the large base of locally financed streets, with no transportation planning consideration for the actual needs of people who desire to make longer trips between the heartland interior cities.

Why shouldn't this couple expect the Federal government to devote a prorated, equal amount of investment in a passenger train route to accommodate a physical limitation, an immutable personal characteristic, such as declining eyesight? They could be just fine driving around town during the day, but have difficulty making long trips by automobile, particularly at night or in poor weather. Once the financial reality of a near parity in required external investment rates between Interstate Highways and Intercity Railroads, as discussed herein is understood, other legal accessibility considerations for Federal decision making become significant questions to answer in setting public policy or upon judicial review of decisions.

It is also important to consider that rail transportation has been tasked by Federal legislation and rulemaking to provide public transportation vehicles with geometries that most closely approach the architectural standards for accessible buildings, far exceeding¹⁹ space requirements in public use Motorcoaches and Aircraft. These accessibility provisions extend to all aspects of travel for those with partial accessibility concerns, such as restrooms available in transit, resting, sleeping, and food service facilities. To the degree that there is a choice between equal financial investment levels for a public service that provides greater transportation accessibility, the sponsoring department may need to conduct a formal review to assure that intercity passenger rail route and amenity eliminations do not reduce the equity required under law.

Correcting for Highway Trust Fund Leverage with a Simple BCA Metric

The last major United States Department of Transportation (USDOT) Amtrak route reevaluation has an interesting side story, starting in 1973 department critiques that cast Amtrak as inefficient relative to Interstate Highways. Congress eventually passed legislation clarifying the public service mission of Amtrak and requested a study. The Interstate

¹⁹ United States Access Board. "Update of the Guidelines for Transportation Vehicles." 1991-2016. <<https://www.access-board.gov/guidelines-and-standards/transportation/vehicles/update-of-the-guidelines-for-transportation-vehicles>>

Commerce Commission (ICC) conducted public meetings, identified benefits to keeping the routes, and published a 1978 report²⁰. But the USDOT still released their final 1979 report²¹ with criteria largely premised on rail passengers paying for both vehicles and infrastructure, a position unique amongst other modes. The root of this same misunderstanding, that the leveraged gas taxes are said to incrementally pay for highway capital, is seen in guidance to this day.

How, one asks, modern era Benefit to Cost Analysis (BCA) methods are supposed to evaluate past and future public funding for transportation projects to select for true resource efficiency? Unfortunately, USDOT policy lacks a nationwide metric for Highway Trust Fund (HTF) formulaic financing that never passes through a modern BCA economic evaluation gate. This is a large effect as the HTF leverages fuel taxes, collected during the use of an almost fifteen-times larger preexisting base of locally funded streets and county roads, towards intercity highway projects, as discussed earlier. When these financial flows fund projects at rates not subject to a BCA throttle, they enable the depression of the market price for transportation, leaving intercity rail able to charge less in a competitive marketplace thus inducing Net losses from depressed Ticket Revenue and higher Operating and Maintenance costs per lesser capacity produced.

Benefits in the BCA process are meant to distinguish specifics of alternatives, not correct for imbalances in programmatic modal funding. For nearly 50 years USDOT guidance has taken that user fees incrementally pay for rural Interstate Highway capacity capital, ignoring that the HTF was specifically set up to leverage when a nationwide toll highway program to fund capital was determined unworkable²².

This 50-year USDOT embargo by guidance, where grants for capital and maintenance of existing intercity railroad infrastructure are routed through a lengthy BCA grant approval process but highway 4R²³ funds are programmatically distributed, needs to be removed for both intercity freight and passenger rail infrastructure funding, or the ongoing USDOT Amtrak Long-Distance Study will likely face the same fate as the 1979 study.

It is up to the USDOT to revise the guidance upon which Congress relies, particularly the BCA Modal Diversion commentary on Price-Demand curves, were no nationwide highway net capital and maintenance deficit is noted. Instead it obliquely notes *“the generalized costs for using the competing alternatives from which an improved facility draws additional users are already incorporated in the demand curve for the improved facility or service.”*²⁴ But if incremental user fees were increased to eliminate the net capacity financial cost, the demand for highway travel would decline, as has been seen when gasoline prices spike, affecting economic models.

As highway projects suppress the market clearing freight and passenger price, pure toll highways for congestion management become nearly impossible except at bottlenecks. The simplest nationwide solution, absent a true market price, is to include a highway incremental financial cost reduction benefit in rail project BCA economic models.

²⁰ Interstate Commerce Commission, Rail Service Planning Office. Evaluation Report of The Secretary of Transportation's Preliminary Recommendations on Amtrak's Route Structure. Washington, DC : ICC, September 1978.

<<https://railroads.dot.gov/elibrary/evaluation-report-secretary-transportations-preliminary-recommendations-amtraks-route>>.

²¹ United States Department of Transportation. Final Report to Congress on the Amtrak Route System, USDOT, January 1979. Washington, DC : USDOT, January 1979. <<https://railroads.dot.gov/elibrary/final-report-congress-amtrak-route-system>>.

²² U.S. Secretary of Commerce. Progress and Feasibility of Toll Roads and Their Relation to the Federal-Aid Program. Washington DC : s.n., 1955. <<https://catalog.hathitrust.org/Record/000968419>>.

²³ Ironically the highway 4-R act involved the beginning of federal funding for maintenance of Interstate Highways previously only given capital grants and substantial resurfacing, restoration, rehabilitation and reconstruction of existing highways, while the railway 4-R act involved a plan to downsize the eastern mainlines so the remaining traffic under Conrail could cover both the long-run capital requirements and maintenance from freight revenue without public investment while placing the commuter mainlines under Amtrak's public expense bracket.

²⁴ United States Department of Transportation. Benefit-Cost Analysis Guidance for Discretionary Grant Programs. Washington DC : s.n., 2022. <<https://www.transportation.gov/mission/office-secretary/office-policy/transportation-policy/benefit-cost-analysis-guidance>>.

The leveraged fuel tax capacity financial metric and intersecting BCA economic metric proposed is termed **Highway Net Incremental Capital and O&M**. The calculation of an intercity rail equivalent value is explored in more detail in the Below-the-Rail Infrastructure section. While this figure does include pavement damage incorporated in some BCA models, its largest component is a capital repayment deficit, the financial net between incremental taxes and fees collected by governments and the long-run infrastructure costs over the last six decades for Interstate Highways. If both Interstate Highway and Railway projects used the incremental cost of dealing with a future capacity constrained state the BCA economic tools could find the most innovative project in terms of safety, emissions, and energy use and crucially forge a plan to improve both types of infrastructure in parallel instead of picking one project or the other.

Conclusion

For the purpose of Identification of Alternatives, the long-run average financial non-user funding of Interstate Highways is to be used as the baseline for evaluating the Financial investment level for the preferred alternative by means of the Highway Net Incremental Capital and O&M metric, which is also used as a Benefit to Cost Analysis Economic metric. The investment program will facilitate a dual investment in the majority use Interstate Highway alternative and the preferred alternative on a nearly equal basis so that the differing needs of traveling persons and economical freight traffic identified will be met.

Interstate Highway - Motorcoach

Much was made during the 1960's of intercity motorcoaches being able to provide for all the common carrier transportation needs outside of those met by airlines. The assumption was that the service could be scalable for all needs and fit under the already accepted interstate financial program. The author will certainly affirm that in several cases intercity motorcoaches fit certain shorter routes.

Intercity buses already benefit from the high capital cost infrastructure of the Interstate highway and less than full maintenance payments through the \$0.17/gallon federal rebate on diesel fuel excise taxes. In comparison, the typical intercity passenger train pays about \$0.65 per equivalent bus mile for use of the rail right of way, but intercity buses are only paying around a total of \$0.015 to 0.05 per mile depending on the state, representing a 4-16% infrastructure cost recovery. This is the difference in operating on a right of way that is owned by the investor held railroads instead of by the government at less than cost. To be on an equivalent cost basis, intercity buses would need to pay an additional \$3 to \$4 per gallon for fuel.

However, the author's best guess for the ongoing cross-subsidy for just using the Interstate highway, outside of the Section 5311(f) intercity bus operating and capital grants, is a bit more than \$0.01 per Automobile Vehicle Mile Equivalent (AVME). This is certainly less than the AVME metric for automobiles proposed as the public infrastructure investment baseline. But the service standards such as space and ride characteristics are significantly different relative to automobiles or other common carriers, limiting the attraction of market volume.

So currently motorcoaches are probably the least cost financial option to governments, but only when supported by the much broader automobile cross-subsidy, which bears much of the capital cost for roadways so as to enable a lower prorated charge to motorcoaches. This was very important prior to intercity rail nationalization, but in the marketplace we have now it would make sense to eliminate all fuel taxes for intercity motorcoaches as they are already paying such a low percentage of their total infrastructure costs that the collection of the charge and rebating a portion is inefficient.

However, motorcoaches have limited market appeal due to the vehicle characteristics. To expand the market volume possibilities, by being on an equivalent user comfort level, intercity buses would need to seat half the current average and provide food service options that allow one to keep traveling uninterrupted. Such a change would radically alter the service economics and resulting ticket price to the point where it would be uncompetitive. The relative space per passenger when compared to an automobile or train speaks to why the price elasticity for motorcoaches is so low under the existing service offerings.

As to fuel efficiency, to begin approaching the seating density of an intercity motorcoach, a single level railcar would need to seat a bit more than 104 people whereas the current standard is 60, eliminate the handicapped bathroom for in-route use, and eliminate the food service car. Even if one full food service car and each rail coach's handicapped bathrooms were kept but the seating moved to 104 passengers per coach car, the average fuel efficiency of 12 car intercity train would be an impressive 218 Passenger Miles (PM) per Diesel Gallon (DG) at a 55% load factor.

For a single level bus seating a maximum of 55, efficiency is 190 PM/DG at a similar occupancy. The new to the US double deck intercity buses claim up to 486 PM/G at 100% load factor so at 55% this would be 267 PM/DG²⁵. However, this bus has a 67" tall upper deck and a 71" tall lower deck and at full capacity the luggage weight is axle weight limited.

But the intercity train mileage was based on an average of 0.24 Diesel gallons a railcar mile. The incremental consumption to add additional cars to a train beyond the 12 assumed above is 0.15 a mile as the frontal air resistance does not increase. Hence the incremental mileage would be 349 PM/DG far greater than any motorcoach. At a 1.09 energy density ratio for Diesel to Gasoline and a 1.4 person occupancy of an intercity automobile the equivalent automobile gasoline mileage would be 229 MPG for incremental rail coaches added to a train, far greater than any possible automobile fuel efficiency target hybrid or not, no matter what the cabin size.

Ideally the existing Section 5311(f) program, with its 15% setaside for intercity motorcoaches, should consider the vital distribution function of motorcoaches in creating a linked common carrier network along with airlines or intercity rail serving as the longer haul backbone. However, even now this principle is being eroded as service to smaller cities by network motorcoach providers has pulled back markedly. The continued entry of the non-stop curbside carriers, which will garner the higher margin fare between larger cities due to lower trip times, might force the elimination of stops by the network carriers in smaller cities as they try to compete financially to maintain their market share of through traffic²⁶. From annual reports the current state of the fares for curbside carriers seems to be related to running "investment mileage" and assigning costs to other units within the company holding governmental contracts. It remains to be seen if the lower fares are the long term stable trend or a market share protection measure.

In summary, there needs to be a means to protect the low cost bus service from the effects of competing in a marketplace with the interstate cross-subsidy. At the same time the motorcoach service is always going to be hard pressed to meet the expectations of the larger travel market due to the vehicle space characteristics and so by default people will then choose automobiles which have a much higher government accident and capital cost. It is preferable to allow Intercity Rail to experience a lower level of cross-subsidy than the automobile as this will result in lower government costs.

The Bureau of Transportation Statistics (BTS) has at times interpreted FHWA provided data²⁷, which does not consider who pays for the overall Interstate Highway costs that are actually funded through leveraging atop excise (gas) taxes on the use of the broad base of locally funded streets or government borne accident costs. The FHWA studies typically only look at the percentage each vehicle class is paying incrementally relative to the low percentage of the total costs of highway infrastructure that are incrementally paid for by excise (gas) taxes garnered between exits. The BTS then uses this data misunderstanding to indicate that there is very little public external investment, or in BTS terms "Net Federal subsidies... the excess of expenditures over revenues", for motorcoach²⁸ highway travel erroneously which may be the source of this type of proposal.

²⁵ VAHPOOL. (2011). TD925 Double Deck Intercity Coach - Specifications & Features.

²⁶ CDOT. (2013). Statewide Intercity and Regional Bus Network Study.

²⁷ FHWA. *Cost Allocation Study Final Report*. 1997. <<https://www.fhwa.dot.gov/policy/hcas/final/>>

²⁸ Bureau of Transportation Statistics. *Federal Subsidies to Passenger Transportation*. 2004.

<https://www.bts.gov/archive/publications/federal_subsidies_to_passenger_transportation/index>

Besides ignoring the overall leveraging of highway infrastructure, another layer of leveraging is applied in such studies and their trade group derivative reports²⁹ by using vehicles as the denominator when determining incremental costs of highway infrastructure as opposed to persons, relying on the much broader base of automobile travel on highways to further dilute the apparent cost of infrastructure for motorcoaches.

Given the relatively low rates of infrastructure recovery and patchwork of state and federal fuel tax rebates anyway it would be better to rebate all fuel taxes for motorcoaches and focus on policies that find the best fit for such vehicles within the marketplace as otherwise the undisclosed limitation in the scope of the FHWA Cost Allocation study data and the resulting BTS interpretation is then in turn used to indicate financial preference. This curious series of conclusions can be traced back to the six decade old narrative regarding limited access highway funding that now has the nation at a crossroads as highway facilities grow older with no clear source of revenue for significant rebuilding.

To balance these tradeoffs intercity motorcoach common carrier operators could be granted access to the large loss insurance pool proposed for Passenger Rail investment and that the ticket prices of intercity rail services be held to a point where they are not less than those of intercity motorcoaches by a certain margin. Given that motorcoaches already use publicly funded infrastructure, whose capital was funded by leveraging allowing a much lower fuel tax on which other reductions have been made, only large scale accident risk coverage would extend to these operations under the proposed grant for full equivalency with private vehicles that benefit from federal insurance programs covering costly auto accidents. However, given the relatively smaller seat space relative to passenger rail and the historic loss of market share to private automobiles for longer trips they would likely serve as feeders to a higher time-utility intercity passenger rail route.

Motorcoach Uses in a Coordinated Ground Common Carrier Network

Conceptually, there is still a demand for solutions to the missing band of intercity travel that has seen motorcoaches used experimentally to fill attempts at even uprated overnight travel in stacked beds, but the inherent rougher ride of a large vehicle, on stiff suspension over variable pavement³⁰ has challenged long term success. Even for daytime use only the relatively much narrower seat widths and higher levels of lateral and vertical acceleration and vibration do not promote comfort, or Time-Utility, on long motorcoach journeys.

The best role for motorcoaches in a coordinated system appears to be as feeders at either the beginning or end of an individual person's trip not a mid-point gap filler due to the way that passengers view the Time-Utility of a transfer when looking for overall productive uses of blocks of time. This is particularly true when the transfer would otherwise occur during early or late hours.

Conclusion

For the Motorcoach alternative it is proposed the publicly funded grant financial framework rebate all of the remaining already fuel taxes paid by motorcoaches due to the already very low amount of infrastructure cost coverage. Additionally, the publicly funded grant financial framework would cover Motorcoach operators using accessible terminals with large-loss risk insurance to provide certainty to both consumers and independent operators who would then enjoy unhindered access to Interstate Highway infrastructure to make the best use for the benefit of persons desiring to take shorter lower volume trips or connect to other transportation modes by motorcoach.

²⁹ Damuth, Robert. "Federal Subsidies for Passenger Transportation, 1960-2009, Focus on 2002-2009." n.d.

<<https://www.buses.org/assets/images/uploads/general/Report%20-%20Modal%20Subsidies%20-%20ABA.pdf>>

³⁰ Rudick, Roger. Cabin Sleep Bus is in Hibernation. 2019. <<https://sf.streetsblog.org/2019/01/17/cabin-sleep-bus-is-in-hibernation/>>

Corridor Rail Single-service train – With Public Below-the-Rail Infrastructure Coverage

As part of rail planning the Montana Department of Transportation (MDT) and Amtrak earlier considered a connection to the existing Empire Builder rail service stations, but one that appeared to require a walking transfer as opposed to a through routing of train cars. The variability of this arrangement leads to a corresponding drop in potential revenue along the route.

While this arrangement is less costly to operate, with just one coach and one food-service car, the initial screening analysis showed an annual ridership of just 15,300 people and annual revenue of \$381,000 against an annual operating cost of \$12,600,000 after a \$159,050,000 capital investment. In this case spending less for the operation of a simpler service produced a larger net loss per person-mile.

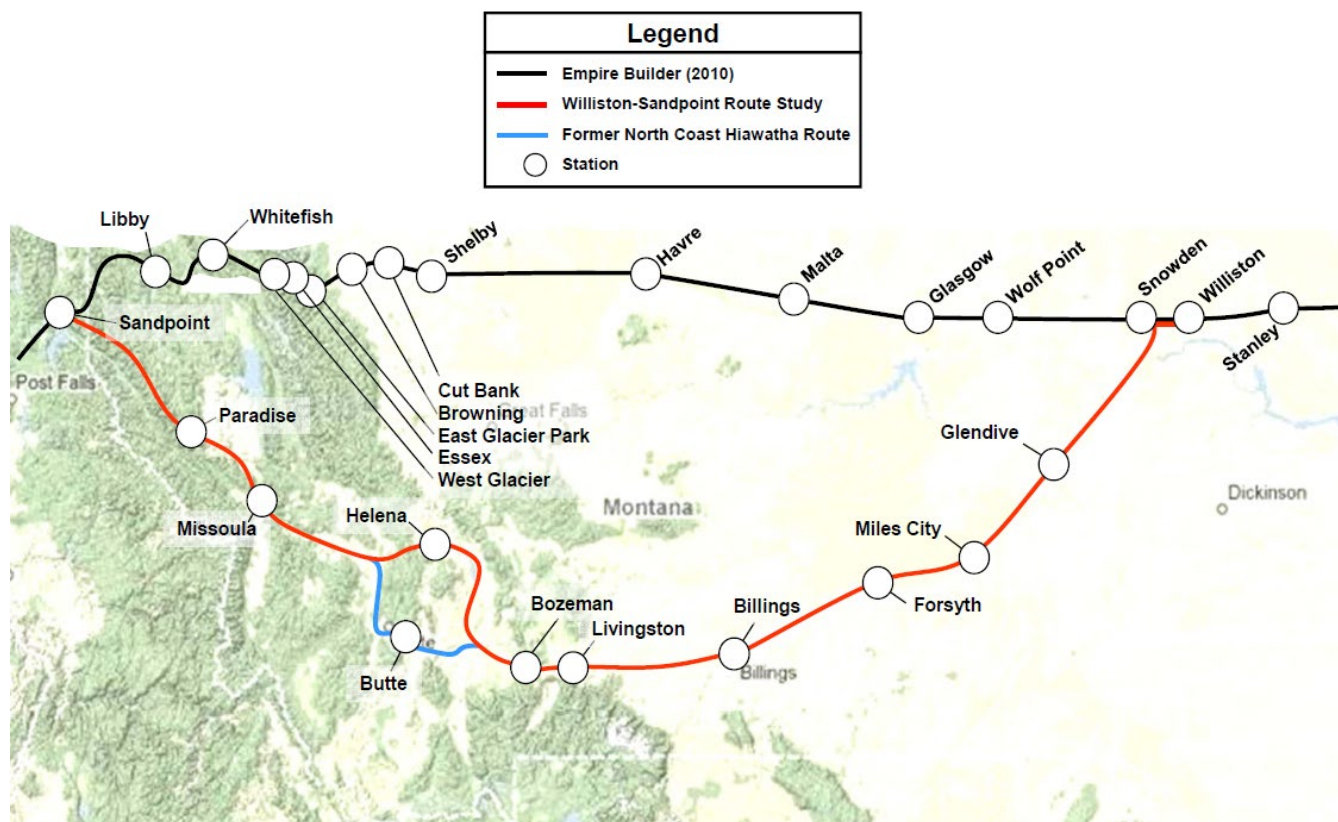

Map of Proposed Rail Corridor without through Traffic

The results illustrate the challenging financial value for the money case for a shorter rail route without supporting through revenue when the route is not serving a congested urban area such as the end points of the longer reinstated *North Coast Limited/Hiawatha* route considered. The next section offers a complete view of situation where a shorter route is justified and how such a route would interact with a Toll Highway for the purpose of considering alternatives that might fit the corridor.

Congested Urban Corridor Passenger Rail and Toll Road Infrastructure Investment Models

It is important to note that the investment metrics proposed have been structured to support a full spectrum of operations between shorter, hourly, urban feeder corridor routes and longer, one to three times daily, National Network connected corridor routes without discrimination. Sometimes the argument is made that a large percentage of Amtrak users travel less than 200 miles in each individual trip, so thus the routes should be shorter. However, without one overwhelming destination, as exists on the NEC with New York, each individual trip will need to overlap atop each other

to produce efficient volume. Consulting the airfare price to distance curve, the competitive breakpoint just on ticket price alone is far beyond the typically quoted 200-400 mile trip distance for rail passengers, stretching to almost 1000 miles for a single traveler once connections are considered from non-hub airports. Numerically, the route itself should be designed to be two to three times the average trip distance to allow for an overlapping of trips by building efficient passenger volume per train-mile.

However, getting back to the larger numbers of travelers making shorter trips, if a person is making the same 200 mile trip say 100 times a year, then federal capital to support 20,000 ground passenger miles is being requested, which is a far greater financial investment than another person's typical usage on the national network routes. An equitable basis must exist for persons in federal investment along with efficiency incentives for whichever operator controls the service.

For this reason the train-mile metric was added, as both corridor and National Network operations would shift toward efficiency under this standard, yet the investment level would be too small to prop-up underutilized train operations, with low passengers per train-mile counts, thereby self-correcting inefficiency through marketplace feedback.



New Build Brightline - Virgin Trains Corridor Rail Passenger Route Miami Terminal – Image Courtesy [Visit Florida](#)

The characteristics of the Brightline - Virgin Trains USA new build corridor deserve consideration as they probe potential nationwide marketplace interactions in the next twenty years with the Interstate Highway system absent massive unchecked general fund investment. From the Virgin Trains USA LLC prospectus³¹ the unique circumstance the Florida Ridership and Revenue Study unveiled is in essence the same consumer economic evaluation of time quality or expressed negatively, disutility of time that the author is pointing to by another name, unpleasant highway travel time, combined with better absolute travel time for many door-to-door airline or highway trips.

Investors were advised that the alternative is a *“Challenging Intercity Trip — At a distance of approximately 235 miles, the journey from Orlando to Miami is relatively short for air travel (with total travel time disproportionately long for the distance given airport security and delays) and relatively long for an auto trip, where traffic congestion can make the four to five hour trip unpleasant and unreliable. Travel volumes on key highways connecting Central and Southeast Florida are expected to exceed capacity by 2030, resulting in further delays and reduction in reliability.”*

Though the most competitive highway route from Miami is a toll road, whose charges of around \$0.07 per mile help the Brightline - Virgin Trains rail route fund itself in a competitive consumer marketplace, some of the intermediate coastal destinations along I-95 served by the new service will be competing against inherently leveraged Highway Trust Fund (HTF) funded highways, where users do not see anywhere near the average cost of infrastructure, as the use of local roads, those funded by local cities and property development mortgages, is taxed through a fuel proxy, then leveraged toward highway investment.

³¹ LLC, Virgin Trains USA. "SEC Form S-1." 2018. Page 91

<https://www.sec.gov/Archives/edgar/data/1737516/000114036119002524/s002218x12_s1a.htm#tIAR>.

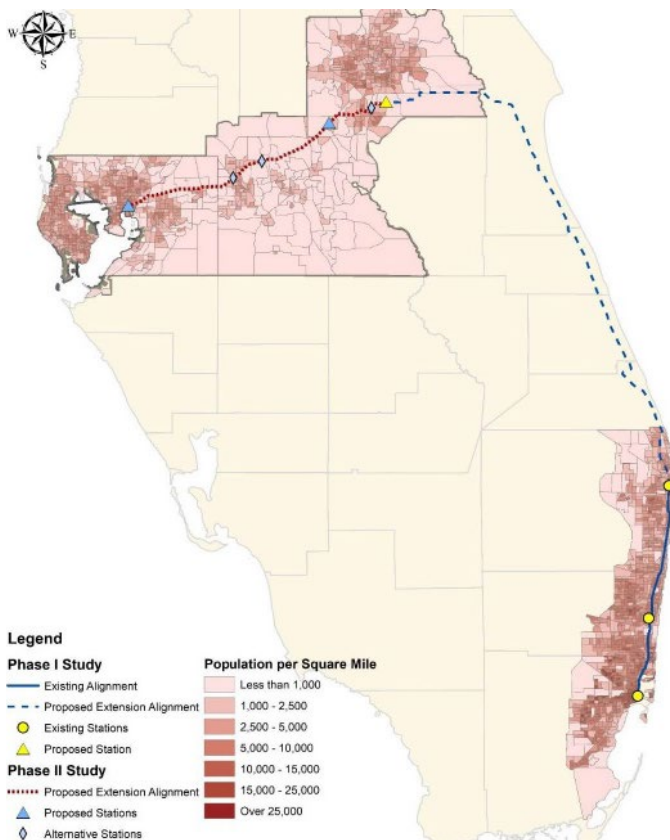

Population Density³² Brightline – Virgin Trains Route

Florida Toll road Segments³³ – Some Partly HTF Funded

However, the nationwide question of HTF scope is providing headwinds to this approach, as recent work to extend toll roads into central Orlando during the I-4 Ultimate (Rebuild) Program demonstrated that even managed lanes providing free flowing traffic through dynamic tolls, have a very difficult time self-funding very large urban Interstate reconstruction programs. Thus some type of solution is going to have to be worked out where projects are ranked by financial efficiency when drawing from the HTF pot, perhaps similar to the author’s per-mile concepts, as otherwise the general lanes will be left unmovable and without significant reconstruction as current and future managed toll lane buildouts in existing right of ways need partial HTF assistance to make these expensive projects happen.

During the I-4 Ultimate proposal phase to reconstruct the urban Orlando area I-4 highway some far reaching projections were performed to see what dynamic toll rates would be justified under future congestion. The I-4 Planning-Level Traffic and Revenue Study³⁴ suggested that by 2045 toll rates would need to be around an all-day average of \$0.60 per

2045 Toll Amounts and Rates per Mile for the 75th Percentile Risk Curve (2010 Dollars)

Description	Length (miles)	Toll Amount by Period							
		AM		Mid-day		PM		Night	
		WB	EB	WB	EB	WB	EB	WB	EB
Eastern Section (Downtown to east of S.R. 434)	12.5	\$9.59	\$7.21	\$3.85	\$4.87	\$6.02	\$7.28	\$2.35	\$2.58
Western Section (West of Kirkman Road to Downtown)	8.6	\$9.06	\$7.11	\$3.85	\$4.67	\$6.14	\$7.28	\$1.46	\$2.43
Full-length (West of Kirkman Road to east of S.R. 434)	21.1	\$18.65	\$14.32	\$7.70	\$9.54	\$12.16	\$14.56	\$3.81	\$5.01

³² The Louis Berger U.S., Inc. "Brightline Ridership and Revenue Study." 2018.

<https://www.sec.gov/Archives/edgar/data/1737516/000114036118043289/s002218x4_ex99-1.htm>.

³³ SunPass. All Florida Toll Roads. 2019. <<https://www.sunpass.com/en/about/whereToUseSunPass.shtml>>

³⁴ FDOT. "I-4 Planning-Level Traffic and Revenue Study." 2012. <https://i4ultimate.com/wp-content/uploads/2012/10/draft-2012-i-4-ml-technical-memorandum_100212.pdf>.

automobile mile on the managed toll lanes to allow for free-flowing traffic in those lanes relative to the overall general lane demand.

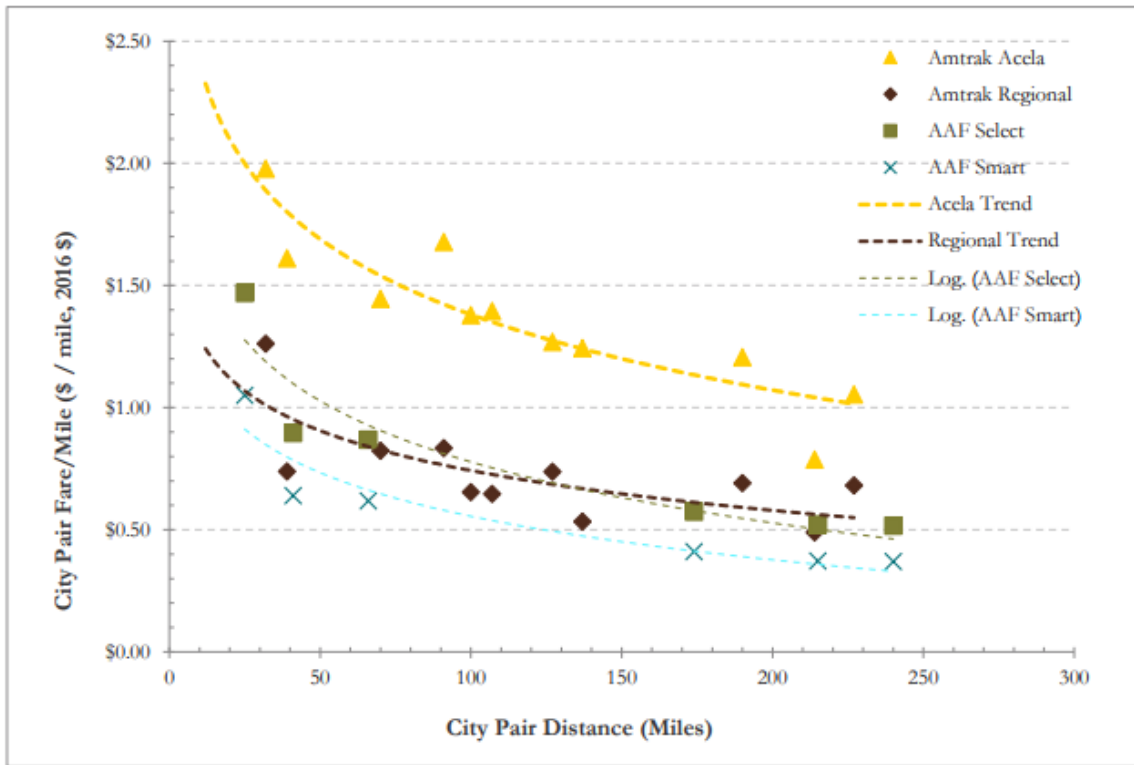

Source: Louis Berger, 2017

Chart of Projected AAF/Brightline (Virgin Trains) Bond Package Passenger Revenue Rates per Mile³⁵

But for this result to be true in a marketplace, the general access un-tolled lanes, largely rebuilt using HTF monies, would be at a near standstill. The author supports beneficial rebuilding of highways though these results demonstrate why this is becoming more difficult in constrained right of ways as well as how the market response signals are going to be gradually restored.

It is also worth noting that any rail passenger route is competing against the federal severe accident cost backstop, provided to highway users though General Fund social programs such as Social Security Disability and Medicaid, that ground common carriers must self-fund. In the case of passenger rail, a \$295 Million large loss insurance policy must provide that backstop. While the amount of the highway backstop is not more than 8% of the total Above-the-Rail cost of the Orlando to Miami rail passenger service, this cost is greater than the entire yearly equipment capital cost for the rail passenger route, which represents one of the more distinctive consumer facing items for revenue generation.

Hybrid Transportation Infrastructure Project Funding Structure =
Public Leveraged Base Funding (Fixed Investment Rate per Mile) +
P3 Managed Toll or Passenger Ticket (At Performance Risk)

³⁵ "Florida Development Finance Corporation Surface Transportation Facility Revenue Bond (Brightline Passenger Rail Project — South Segment), Series 2017." <<https://emma.msrb.org/ER1107449-ER866075-ER1266758.pdf>>

Under the proposal in this corresponding Public investment paper³⁶ the private rail operator should be able to receive coverage from the proposed USDOT large-loss liability backstop. There is also the question of cost responsibility for ancillary improvements, such as street grade crossings, as the HTF is providing many of the funds needed in the I-4 project to revise local roads and existing general purpose Interstate lanes outside the toll cost structure while in contrast the Brightline project is fronting many of the costs for existing crossing improvements and only asking for certain maintenance to be accepted in the future by public authorities, for which they have been sued by various counties for alleged inequality.

Corridor Rail and Mid-Route Bus Bridge - Increase Operational Costs that could Instead Fund Infrastructure

In 2018 Amtrak proposed to revise the Southwest Chief route to include a mid-route motorcoach bridge for which some details were provided on August 8, 2018, suggested to meet their own operating limitations atop the long standing Federal Railroad Administration standard for PTC exemptions. A summary chart of the options is reproduced below, with Option #1 being the existing through routed Southwest Chief. This case study is useful to consider why a mid-route motorcoach bridge is a poor financial and service provision option.

Option #1		Option #2		Option #3	
	FY18 Base	FY18 Base	Estimated route P/L	FY18 Base	Estimated route P/L
Total Revenue	\$53.023	\$53.023	\$24.167	\$53.023	\$23.277
Total Frequency					
Variable Cost	\$55.828	\$55.828	\$35.953	\$55.828	\$38.105
Total Route Variable Cost	\$23.042	\$23.042	\$22.106	\$23.042	\$22.106
Variable Operating Contribution	-\$25.847	-\$25.847	-\$33.892	-\$25.847	-\$36.934
Ridership	363,269		238,900		240,500

Option #1 Existing Passenger Rail Through-route has Lowest Investment versus Bus-Bridge Options #2 & #3³⁷

Amtrak suggested route cost figures are showing that the total variable cost of the 2018 Southwest Chief is \$78.87 M on 1.649 Million train-miles, or \$47.83 per train-mile, which typically excludes some equipment capital, but counts the track and terminal access as an operational cost instead of infrastructure capital as done for the owned Northeast Corridor route. The noted variable investment required after revenue for this very long route works out to \$15.67 per train-mile by Amtrak’s numbers, or about \$0.11 per automobile equivalent mile, less than the six-decade leveraged Interstate Highway investment rate derived from taxes on the use of locally funded streets as detailed in this study.

The Amtrak proposal to convert the middle section to a motorcoach bridge is actually shown to increase the operating loss even using optimistic remaining revenue numbers. The suggested additional \$11.09 M yearly operating loss should the middle section be converted to a bus bridge would be able to self-fund a present day capital infrastructure

³⁶ Payne, Virgil G. Renewed Consumer Relevance of the General Railway System. *Railway Age*. 2021, <<https://www.railwayage.com/news/renewed-consumer-relevance-of-the-general-railway-system/>>.

³⁷ Amtrak 8/18/2018 Presentation to stakeholders – Proposals #2 & #3 for Bus-bridge now on hold indefinitely

investment of \$145 M at the 2018 20-year US bond rate of 3.4% plus a 1.0% loan premium. This \$145 M equivalent present value is much more than Amtrak's suggested capital cost of keeping the route operating as a through route, absent the recent suggestion of an expensive sole use full-PTC installation not found to be required by Federal Railroad Administration rule making and risk analysis. Additional grant programs have already been approved to further defray Amtrak's portion of the route infrastructure costs with limited matching funds. Later in this work, much more economical means to obtain almost all the safety benefits of full PTC are outlined.

The bus bridge as proposed in 2018 by Amtrak would not work due to the reality that the seating area per person is much more constrained on a motorcoach to around 17" as is typical on commercial aircraft around half that found on current train coaches. The analysis in Benefits section is a conceptual explanation through an objective seating area analysis of the preference that many surveys have found for a passenger train over a motorcoach for common carrier ground transportation. Asked another way, more than 50% of current train passenger would drive instead should the train go away as an option against 10% who would ride a substitute motorcoach³⁸. On a larger scale, as passenger trains were curtailed people shifted to automobiles³⁹ as the next most logical and preferential ground transportation choice over motorcoaches.

However, the revenue estimates for the long Motorcoach Bridge Options #2 & #3 seem to overestimate remaining revenue. By analyzing the city pair segments and applying Time Utility derived loss factors for each transfer, it appears that Options #2 & 3 would only retain about 63% of the ridership, 48% percent of the passenger-miles of transportation, and 37% of the total revenue, around \$16.3 M, instead of \$23.3 M, while 76% of costs, \$60.2 M, would continue to be reported, potentially yielding a \$18.0 M increase in funding required annually, further available to offset capital investment.

Conclusion

For the purpose of Identification of Alternatives, due to the particulars of this route geography the various forms of Corridor Rail Single-service operations without through car revenue discussed are removed from consideration though such a service would fit other high-volume corridors.

Long-Distance Rail Multi-service train – With Public Below-the-Rail Infrastructure Coverage

Optimal Size of Intercity Rail Consist:

A 1959 ICC hearing on the Railroad Passenger Train Deficit did not draw any conclusions on the question of optimal rate policy but did state "*... that the railroads are best suited to volume carriage and that in order to put passenger travel on a paying basis they must devise ways of encouraging volume travel.*"

Space is cheap on trains, the high cost-elasticity relative to other modes for intercity rail demonstrates that there is a limit on the numbers of passengers willing to choose bus or aircraft that have not already done so due to mode characteristics. However, many are willing to use the train as a substitute good if the price decreases relative to the private automobile.

There are substantial financial costs in running any type of train over the existing shared infrastructure at moderate speeds. This is due to the fact that the line is optimized for heavier haul at lower speeds. The way to counter this is of course to generate volume to cover those costs or invest capital in new facilities as was done for aviation and highways. But without recognition of this fact and given the marketplace cross-subsidies in place it is difficult to impossible to generate the capital needed for equipment to start this effect of lowering prices and gaining volume. The following

³⁸ Rail Passengers Association. How would passengers travel without trains? 2019. <<https://www.railpassengers.org/happening-now/news/blog/how-would-passengers-travel-without-trains/>>.

³⁹ Thompson, G. L. (2011). Public Policy or Popular Demand? Why Californians Shifted from Trains to Autos (and Not Buses) 1910-1941.

model illustrates the lowering of the financial average costs to levels much below the marketplace cross-subsidy for the Interstate network.

Elasticities of Demand for Intercity Passenger Service				
(Percent)				
	Automobile	Bus	Rail	Air
For Vacation Trips				
Cost	-0.45	-0.69	-1.20	-0.38
Travel Time	-0.39	-2.11	-1.58	-0.43
For Business Trips				
Cost	-0.70	-0.32	-0.57	-0.18
Travel Time	-2.15	-1.50	-1.67	-0.16

Source: Steven A. Morrison and Clifford Winston, "An Econometric Analysis of the Demand for Intercity Transportation," *Research in Transportation Economics*, vol. 2 (1985), pp. 213-237.

Illustration of Elasticity. Note the highest willingness to use Rail of those not so doing now if Price declines.⁴⁰

One might object to an expansion of such a service if recent history was not consulted. Even up until the late-1980's several routes operated with much more revenue space than today, though less than proposed. Since then, significant regional population increases have occurred. Congress ultimately rejected the proposal to re-equip the single level long distance trains using 1200 cars put forward during that era. Once the inherited fleet began to wear out, the resulting service volume cuts hurt the ultimate bottom line, but few noticed as the policy had been turned toward high-speed short-haul corridors.

Previous National Network Passenger Rail Route Eliminations Have Not Saved Costs

"I will be as straight as I can, Senator. First of all, I do not play politics with trains. The elimination of the Pioneer preceded me as the president of Amtrak, and I cannot speak to what the basis was for that decision. I will tell you, though, that generally, in retrospect, all of those eliminations back in 1995 and 1996 ended up costing the company more in lost revenue than we were able to take out in the way of expenses, given the fixed cost nature of the operation." Statement of Former Amtrak President Mr. Warrington in 2000 to the US Senate⁴¹

For intercity rail a long history of trying to reduce incremental expenses on the National Network of Long-Distance Amtrak routes through cuts in both onboard amenities and the 1979, 1995, and 2005 route reductions, has led to increasingly poorer results, while leaving behind both interstate travelers and the high fixed costs of the remaining NEC urban congestion relief network.

Each round of cuts was typically preceded by a decision not to invest in equipment suitable for longer trips and cutbacks in onboard food amenities on the long-distance trains that drive ticket revenue through Time-Utility gains for consumers. Instead, these routes should be evaluated atop a base investment set at the same rate of Federally coordinated, leveraged investment above and beyond the direct (gas) excise taxes collected on Interstate Highways, with the investment set at a fixed rate per train-mile for Below-the-Rail facilities and infrastructure. Atop this fixed base investment, internal Amtrak metrics should consider incremental financial revenues and expenses to guide a business

⁴⁰ CBO. (2003). The Past and Future of U.S. Passenger Rail Service.

⁴¹ Senate Hearing Committee on Commerce, Science, and Transportation 106th Congress. - OVERSIGHT HEARING ON AMTRAK, 2000. <<https://www.govinfo.gov/app/details/CHRG-106shrg85968/CHRG-106shrg85968>>

case for revenue funded operations and equipment reinvestment, the same standard to which other public intercity transportation modes are held.

1969 Interstate Commerce Commission Cost Study

The Interstate Commerce Commission (ICC), the predecessor to the Surface Transportation Board (STB), began to change toward the end, determining the avoidable expense of running passenger trains on routes similar to long-distance routes to be \$6.7 per train-mile in a 1969 ICC report⁴² to Congress, equivalent to \$48.7 per train-mile in (\$2018), yet Amtrak reports a Total Assigned Cost of \$62.5 per train-mile for today’s much smaller capacity, simpler to maintain trains, in turn reporting large losses from these assigned numbers to cover infrastructure elsewhere and overhead.

Undoubtedly, some of the difference reflects real diseconomy of scale in a single daily train in each direction, but the Total Allocated Costs reported by Amtrak for such routes include many fixed costs prorated to the route that would not be eliminated with the discontinuance of the route or segments of such. The exhaustive ICC study provides an independent collaboration of the financial model levels which show that passenger trains have a declining average cost curve with respect to increased volume at the current operating levels, providing a revenue to cost solution should rail infrastructure investment be understood in light of the highway investment leveraging from taxes on locally funded streets.

TABLE 3. -- Avoidable operating expenses per train mile

Carrier	Train miles	Avoidable operating expenses	Avoidable operating expenses per train mile
AT&SF	8, 642, 825	\$57, 913, 822	\$6.70
SCL	7, 436, 061	48, 539, 753	6.53
UP	6, 622, 129	41,040, 983	6.20
C&O-B&O	4, 506, 432	28, 933, 668	6.42
GN	4, 045, 483	26, 201, 749	6.48
SOU	4, 032, 099	25, 229, 477	6.26
IC	3, 559, 984	23, 375, 010	6.57
MP	1, 820, 169	8, 113, 216	4.46

Summary Figure from ICC Report - Investigation of Cost of Intercity Rail Passenger Service, 1969

Expanding Intercity Rail Service Types with Product Differentiation

Absent sufficient revenue from different passenger accommodation tiers and express, a long-distance passenger train can be like a 4-engine regional jet, with high fixed costs and skimpy revenue per mile.

Since additional space is cheap on trains it makes sense to offer coach options that provide for more personal space. One option would be to offer 2-1 seating plans as a business class coach that would become the standard for reserved travel. In this arrangement a pair of two seats is on one side of the aisle while a single seat is on the other. At the time the reservation is made, the passenger would be assured that they would only have a seatmate if they so desired, through selecting a guaranteed private seat pair or not. If the operator would price either the single or double seat pair

⁴² Interstate Commerce Commission. "Investigation of Costs of Intercity Rail Passenger Service." 1969. <<https://babel.hathitrust.org/cgi/pt?id=mdp.39015004568708;view=1up;seq=49>>

at near the incremental cost of operating an automobile, they would markedly expand the volume of passengers on each route.

A single traveler would gain a lot of utility from not having to worry about the quality of their trip time due to a seatmate while maintaining the social aspect of the trip, and the overall occupancy factor could be booked closer to 100% without worry of customer dissatisfaction. Such a single level car would have a capacity of 58 passengers at a 38" seat pitch, equal to airline business class, though with wider seats.

To compete for budget travelers, a 2-2 seat arrangement, two seats on either side of the aisle, would allow for 96 passengers per single level car at a 32" seat pitch, yielding more personal space than that provided on a quality motor coach.

Convertible flat pod beds that provide 2-2 seats during the day but then a pair of those seats becomes a pod bed are another way to provide additional options. The key is to provide for as many different market segments as possible in a single train to generate financial returns through volume.

As to food service amenities, or really any amenities, a Long Distance overnight train can be thought of as a hotel that maintains a lobby filled with couches and a seated dining room, but only to attract customers. Once provided, many choose based on marginal cost to use cheaper café or self serve food options, but they made the decision to book the hotel based on the amenities. An expanded volume base to place these costs on improves cost effectiveness to the point where fixed costs for the amenities are minimal compared to revenue gains. Most of the need for subsidy is just in the act of running any train on the existing infrastructure without capital improvements.

There would also be an opening for a mid-distance overnight Auto-Ferry, serving the 400-600 mile trip lengths. Such a service could represent a fully marginal revenue addition on existing trains, providing an extended range for business trips as well as superior consumer surplus and cost to a two-hop regional jet trip, connecting through a hub terminal, hotel, and rental car. Alternately, it could operate as a standalone service along with plate van trailer-based freight intermodal in the same consists as the passenger cars but with fewer intermediate stops, particularly during overnight hours.

There could also be a market for pallet-based freight, using advances such as the automated pallet handling equipment already developed so that only a single loading and unloading spot could be employed to exchange pallets from several cars. Innovations such as these, if adopted, would allow the per passenger mile cross-subsidy figure to drop to well below the Interstate equivalent.

Lessons should be learned from the primary competition for long highway trips, SUV's, which feature greater in-cabin quality measures derived from the higher seating position that allows for better viewing and larger cabin volume and plan. To add this preferential revenue stream to what is a relatively thin amount of travel between origins and destinations along the corridor the train operation needs to explore enhanced food and beverage service and a mix of coach, flat-pod beds, and private sleeper accommodations for travelers whose details are explored in the Above-the-Rail section. By combining service levels in each train, many more rural routes are profitable Above-the-Rail at lower volumes.

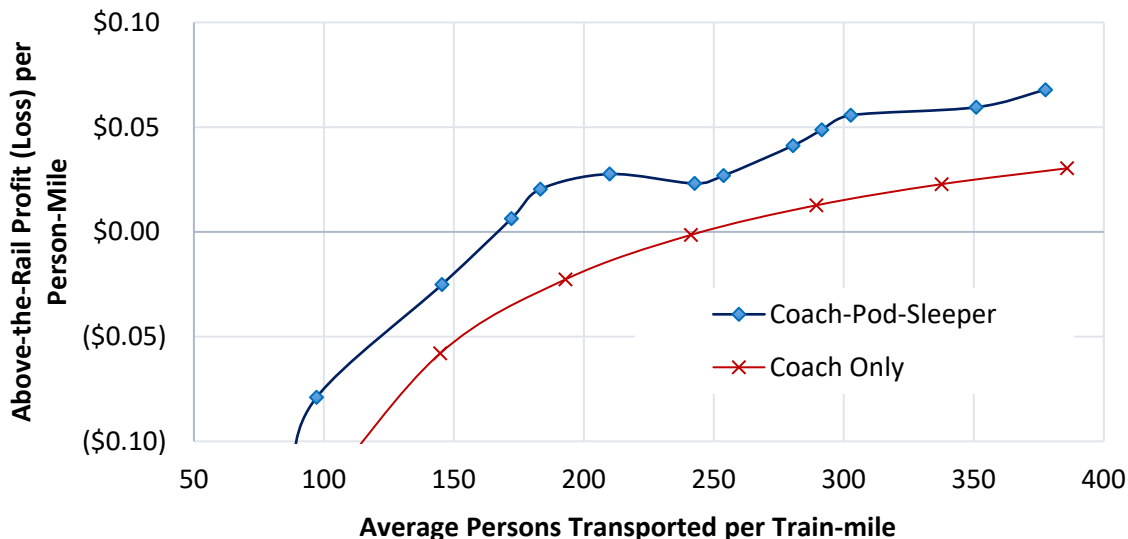

Profitable Volume Point for a P3 Passenger Operator with only Above-the-Rail Responsibility based on Service Type

A multiple market service long-distance train has the unique ability to serve a rural route that generates relatively less potential revenue by supporting itself from customer revenue when Below-the-Rail Infrastructure is provided at an equivalent investment to that of Interstate Highways. The particulars of the proposed Above-the-Rail Vehicle Operations are considered in later sections.

Conclusion

For the purpose of Identification of Alternatives, the Long-Distance Rail Multi-service train – With Public Below-the-Rail Infrastructure Coverage paired with Motorcoaches providing short connections at the start or end of the trip, is selected for further development to meet the proposed NEPA Purpose and Need.

Planning Methodology

Consider Lessons from the Historical Service Operation and Routing

The point of considering the historical service is to try to replicate the amenities that kept the *North Coast Limited* and its schedule mirrored companion daily train the *Mainstreeter* running until the beginning of Amtrak in 1971 as well as consider the routing and connecting revenue opportunities.



North Coast Limited in the Montana Rockies, 1969, Steve Brown⁴³

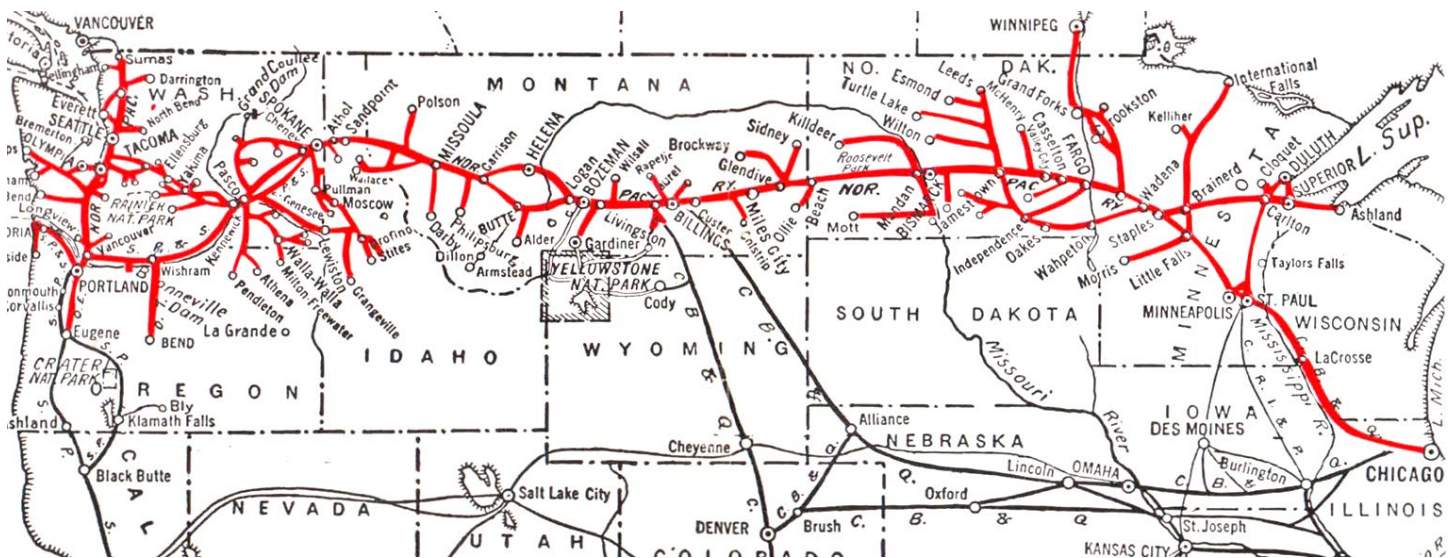

Combined Mainstreeter and North Coast Limited Through Route and Connections - 1966⁴⁴

⁴³ Riding the North Coast Limited, Flickr Album, <<https://www.flickr.com/photos/sjb4photos/sets/72157606072881534/>>

⁴⁴ Northern Pacific Spring 1966 Timetable, From Streamliner Memories Collection, <<http://streamlinermemories.info/?p=5556>>



North Coast Limited in Butte, Montana, 1969, Steve Brown



Morning at Mandan - North Coast Limited, 1970, Steve Brown

Consider FRA Amtrak Daily Long-Distance Study Routing

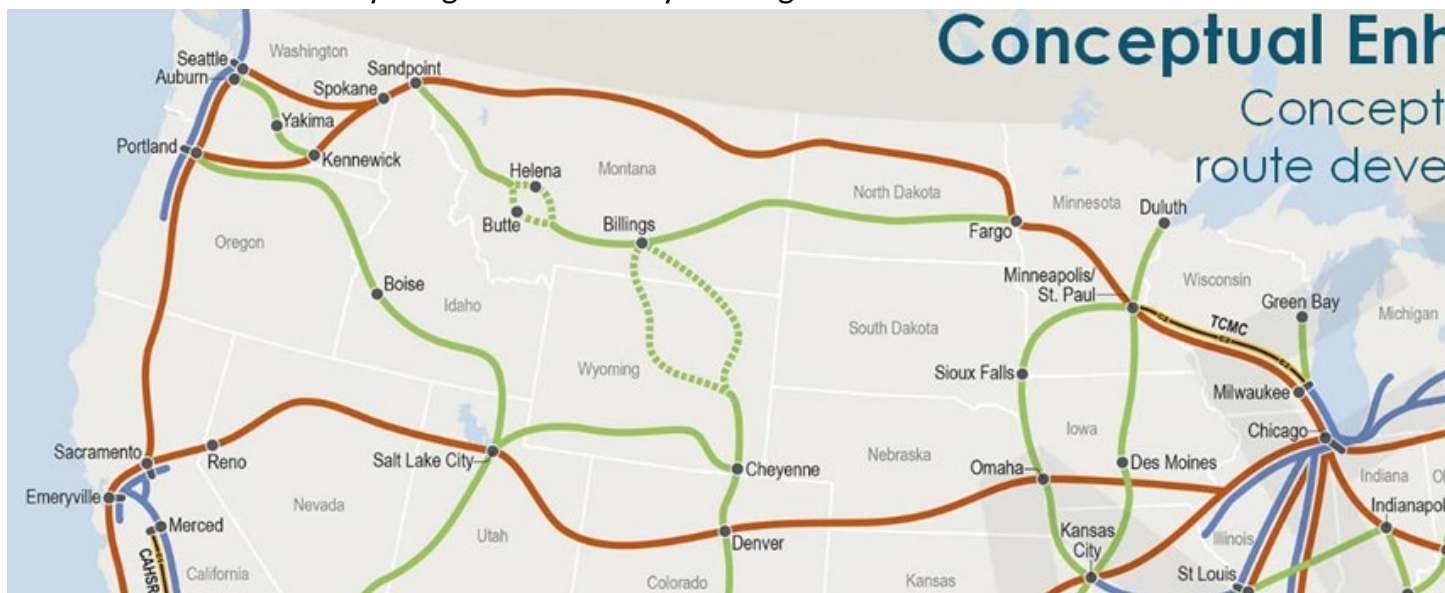

Detail Map of Western Study Routes in Amtrak Daily Long-Distance Study, Conceptual Enhanced Network⁴⁵



General View of Corridors Considered: Existing Long-Distance Passenger Rail Routes in Thin Purple

- Green: Trunk Route Proposed Minimum Operable Segment (MOS) to Meet Some Objectives
- Blue: Alternative End Terminal Feeder Route
- Red: Denver Feeder Route
- Yellow: Salt Lake City Feeder Route
- Cyan: Major Motorcoach End Feeder Route

⁴⁵ FRA Amtrak Daily Long-Distance Service Study, 2023, <<https://fralongdistancerailstudy.org/>>

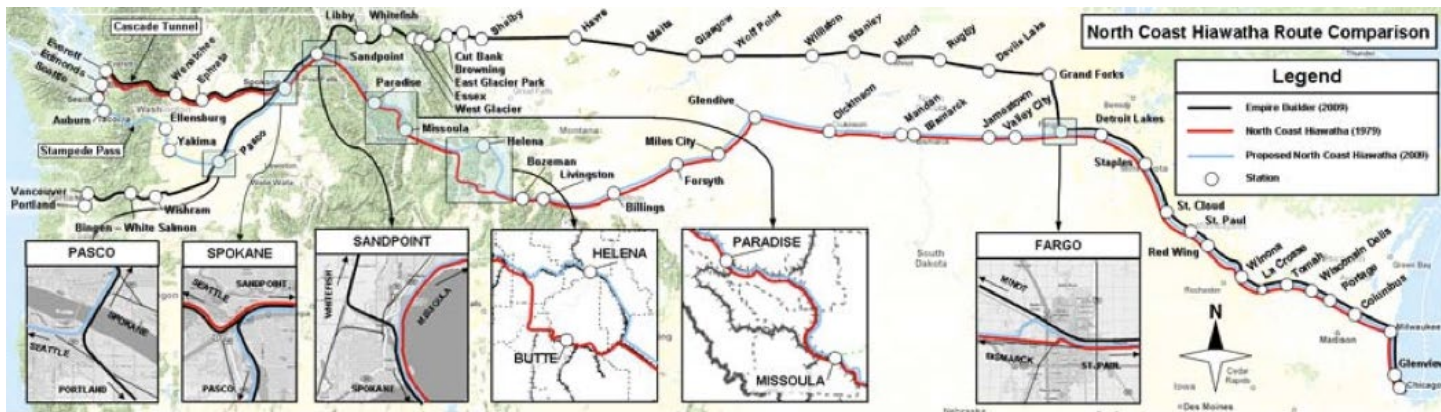

Map of North Coast Hiawatha Routes from 2009 Amtrak Study

Improvements to the Origin and Destination Models

To date none of the methods employed in the studies seem to have considered the time of day for trips, either the available departure time or the desired arrival time. Instead, the amalgamated trip tables have been used that just provide the trips per day by mode. However, this approach is missing the ability to consider feeder motorcoach or rental car opportunities or conversion of highway traffic to overnight rail that really cannot be understood without a very tight origin and destination boundary correlated to these times.

Modern anonymous cell phone data allows for geofencing around points of interest and the ability to put together a picture of what a full trip looks like. Once driving exceeds a daytime journey, the intended Origin and Destination results are likely skewed. The full SDP should collect data and tabulate it for bidders as well as apply it to the Time-Utility revenue model detailed in the Demand and Revenue Analysis section.

National Parks – Destinations and Onward Journeys

The full P3 SDP should consider journeys that proceed on a north-south axis through Yellowstone National Park by encouraging an integration into the park’s concessionaire’s reservation booking platform⁴⁶ and providing connecting motorcoach and one-way automobile rentals. This would necessitate private agreements over revenue sharing and cross-marketing but would likely generate significant consumer revenue to the route that would allow for the twice-daily in each direction model to provide economical service to intrastate trips within Montana, Idaho, and Wyoming.



Xanterra Operated Yellow Bus Tour⁴⁷

⁴⁶ <https://www.yellowstonenationalparklodges.com/>

⁴⁷ <https://www.yellowstonenationalparklodges.com/connect/yellowstone-hot-spot/the-coolest-way-to-tour-yellowstone/>



Historical Timetable Showing Yellowstone National Park Access Routes – Coordinated Packages



Conceptual Feeder Route Circle around Major Western Parks from Domestic/International Gateway Airports

On a larger scale cross-marketing should be considered in the P3 fully developed SDP for through ticketing from the larger domestic and international hub Gateway Airports with overnight travel substituting for a hotel.

Demand and Revenue Forecasts

Vehicle Travel Time Savings (VTTS) - Time-Saved Analysis

Consumers have demonstrated, through real world high-occupancy-toll road purchases (revealed preferences), a willingness to pay only around \$7 per hour for travel time-savings (although this will vary by region),⁴⁸ much less than the conventional U.S. Department of Transportation value of \$19 per hour.⁴⁹ However, they also have shown a willingness to pay around \$22 per hour for reliability savings not tied to higher speeds. This is concerning from a design rationale standpoint, as these theoretical time savings typically account for most of the public benefits in a transportation economic benefit-cost analysis. Other studies of actual toll transactions have reported willingness to pay at around \$2 to \$8 per hour of travel time savings among all users, based on the majority deciding against use of the tolled managed lanes and the minority using the lanes being willing to pay much more. The latter calculation might be the more reliable estimate in this author’s estimation.⁵⁰

This overemphasis of speed to gain time savings overwhelms safety benefits in current models and limits the exploration of reliability and connectivity benefits that could occur with different network designs and target speeds.

Current models presuppose that we highly value just a few net seconds saved from driving faster, yet farther, on a wide 50-mph urban arterial collector instead of on a connected 35-mph street.⁵¹ This is assumed in value of travel time-savings (VTTS) methods (despite the potential public discontent regarding the unavailability of a local street grid onto which to detour in the event of accident backups). Concentrating urban daily traffic onto large at-grade arterials—where all traffic is concentrated at surface intersections instead of bridging over—is the default option resulting from road-widening projects pursued at high cost instead of developing grids of many streets. This has been a recipe for unreliability for the same reason that a wire rope is made of many strands, not just one.

Urban designs are being advanced for the wrong reasons under VTTS metrics. Instead, given that the construction is actually financed by local property taxes, time-utility economic metrics should be used to design facilities for greater interconnectivity of local travel and enhancement of property values.

Total Trip - Time-Utility Analysis - Fits Real Traveler Choices

Conceptually, we all know that time has different positive and negative values in an economy. We actually pay for the privilege of sitting in a coffee shop “wasting time” away. Even our recounting of the quality of an experience suggests different values. If we say “*We had such a great time at dinner last night, the time just flew away...*” then the perceived cost of that time was low. If we say “*The line inched along behind the accident backup, the time drag on forever...*” then the perceived cost of time was high, so that it could be measured as an economic disutility to that person, relative in

⁴⁸ “We estimate that VOT [or Time-Savings/VTTS] is only \$7/hour for the preferred specification while VOR [or reliability as a part of Time-Utility] is over \$22/hour. In aggregate 68% of the benefits to HOT users are from increased reliability.” Austin Gross and Daniel A. Brent, “Dynamic Road Pricing and the Value of Time and Reliability,” Working Paper 2016-07, Department of Economics, E.J. Ourso College of Business, Louisiana State University, June 2017, p. 5, http://faculty.bus.lsu.edu/papers/pap16_07.pdf.

⁴⁹ U.S. Department of Transportation, “Benefit-Cost Analysis Guidance for Discretionary Grant Programs,” January 2020, https://www.transportation.gov/sites/dot.gov/files/2020-01/benefit-cost-analysis-guidance-2020_0.pdf.

⁵⁰ “Another reason for the low value of travel-time savings, as used in this paper, is that only a small percentage of trips by transponder-equipped vehicles, approximately 7 percent, chose to pay to use the MLs [ed. Managed Lanes are HOT/Toll lanes]. For those 7 percent of trips, the average VOT was \$39.65 per hour, a fairly high willingness to pay. However, when combined with the 93 percent of travelers not willing to pay the toll, the average VOT dropped to between \$1.96 per hour and \$8.06 per hour.” Mark Burris, Cliff Spiegelman, A. K. M. Abir, and

Sunghoon Lee, “Travelers' Value of Time and Reliability as Measured on Katy Freeway, Final Report,” PRC 15-37 F, Texas A&M Transportation Institute, Transportation Policy Research Center, September 2016, p. 18, <https://static.tti.tamu.edu/tti.tamu.edu/documents/PRC-15-37-F.pdf>.

⁵¹ A collector is a type of road between arterial and street.

both cases to what one wanted to be doing at that time of day. There is always a difficult task to model the financial result of just the value of time, what one would pay with cash, but it does affect a consumer's choice of an overall product very much, hence the use of economic models.

But what if the economic models traditionally used for transportation fail to capture values for long-distance travelers?

Herein is another overlooked key to designing a transportation network. The conventional USDOT approach, originating from 1950 era transportation planning methods, is to use an economic benefit-cost analysis to judge transportation projects, using set values of in-vehicle time savings, known as Value of Travel Time Savings (VTTs), that are largely the same across various types or modes of ground transportation, which are then compared to infrastructure financial costs. Further still even to this day US modeling completely ignores time of day drivers in trip generation calculations.⁵² Contrary to many experiences where the first question asked in planning a trip is when will we get there.

While it is largely true that say consumers will pay not much more for a slightly more comfortable airline seat, as they perceive almost all of such experiences to be nearly the same, bearing the same utility; it is not true that options that enable significantly different beneficial activities to occur are disregarded by consumers, say a flat-bed airline seat.

For example, friends of the Author would wake up very early to start a long car trip, with the goal of driving while their young children were still asleep. They gained more net utility of time from driving overnight in that they could talk quietly and continue the trip peacefully. In this case the government still invested at the same average financial value for the below-the-road infrastructure, but based on consumer economics they choose a different product so to speak, a partly overnight car trip. As another example, do consumers buy crossover because they are faster or cost less, or because the time spent is more enjoyable within them due to the interior volume and seating position? Perhaps aspiring after high speed rail is not the only solution to the problem, though a long-distance train operating at 90 MPH over several connected segments is perhaps already a very good compromise between though route speed, comfort, and access to population centers.

Passenger rail operators outside the US have explored Quantifying true consumer preference for utility of time onboard, terming it a Value of Comfort (VoC)⁵³ planning metric, which explores productive use of time for mobile work, rest, dining, drinks, and other hospitality services which could extend into the beginning and end experience of the entire trip, such as through sheltered taxi drop offs, onward local transportation, or short duration rental cars booked at the same time as the ticket purchase. These type of consumer evaluations can be compared to relatively expensive mainline speed improvements to achieve reduced times in just the main segment that consumers may not view as highly if other parts of the trip are disagreeable.

Ideally, for daytime corridors this could take the form of a circular slow speed distribution run around the metro area so that intercity passengers could board at a close by station and have a one seat ride with few transfers as proposed as a "Metro Flyer", instead of one central station connected by a non-stop high-speed rail link. For overnight National Network long-distance trains it means various ways to allow the trip to start and conclude at highly demanded times, through twice daily operation of a mirrored interregional through line schedule or by through car lines set-out at major en-route station sidings for desirable boarding and alighting times.

⁵² Federal Highway Administration. "Foundational Knowledge to Support a Long-Distance Passenger Travel Demand Modeling Framework Part A: Final Report." 2015. <https://www.fhwa.dot.gov/policyinformation/analysisframework/docs/national_model.pdf>

⁵³ KiM Netherlands Institute for Transport Policy Analysis. The Value of Comfort in Train Appraisal - English Summary. 2016. <<https://english.kimnet.nl/publications/papers/2016/10/5/the-value-of-comfort-in-train-appraisal-kopie>>

Sketch-level P3 Service Development Plan – Demand and Revenue Forecasts

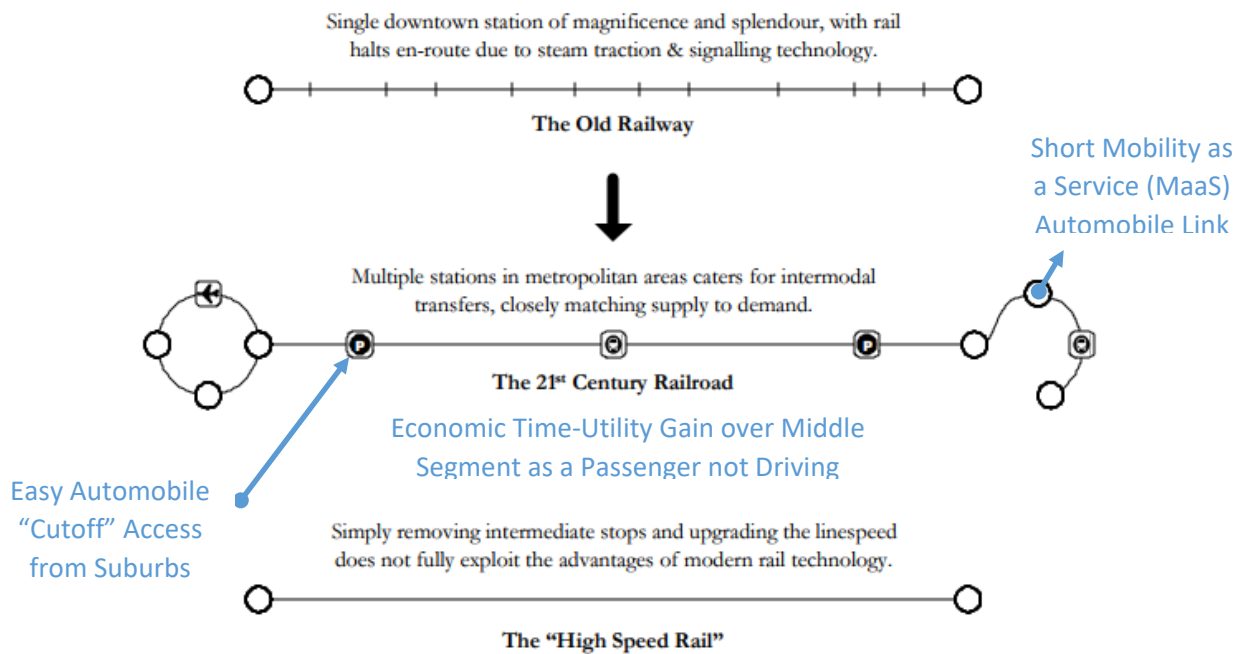

Automobile Access shown on Chart from MetroFlyer Proposal of Dr. Martland and Dr. Lu.^{54,55}

As an example minor schedule revisions could produce more attractive arrival times into the Los Angeles metro area on the Southwest Chief route. After all, more utility to a traveler is had arriving at 8 AM after an overnight trip than arriving earlier at 6 AM, before being forced out to a waiting room before other businesses open. Consumers generally look for travel options that allow them to accomplish the same daily activities they want to do at near the same time that they would do them otherwise, while aspiring to gain the benefits of leisure or business travel. Along the way, consumers of ground transportation often make choices for more expensive, but more comfortable arrangements.

This approach will require incremental rebuilding the existing network at a much lower cost than building just a few high speed routes, as the name of the game is broad network coverage at reasonable cost. Local networks of general system rail around urban areas would support both intercity rail, commuter rail, and ideally domestic freight intermodal terminals, which would all combine for efficiency.

Pricing Approaches

Prices should be set on travels parties, with costs increasing only slightly as the party increases, equivalent to automobile costing. This is a better way to segment the marketplace between Business and Leisure travel, particularly for families. So in this way the advance pricing for groups of coach passengers that could fit in a single automobile would begin to level off as it approached the \$0.40 per mile variable cost measure for automobiles. Groups of sleeper passengers would see the cost level for a combined suite of bedroom accommodations level off below the \$0.80 per mile full cost of a full SUV. Atop this pricing index advance purchase discounts could be set in the reservation system to manage demand.

Reduced Access Cost Toward and Within Stations

Coordinated one-way daytime automobile rental segments added to ticketed itinerary from an off-line community to a station could serve to expand the market reach for premium long-haul multi-city services and for those who might not

⁵⁴ Alex Lu, Dalong S. Shi and Carl D. Martland. "The Vital Role of Metropolitan Access in Intercity Passenger Transportation." MIT, 2002. <<http://www.mit.edu/~uic/metro-TRBv3.6.1.pdf>>.

⁵⁵ Lu, Alex. "From the Limiteds and the Zephyrs to the 21st Century MetroFlyer." MIT, 2003. <<http://www.mit.edu/~uic/TRB-handouts.ring.8.1.pdf>>.

have an automobile available to can make a long trip reliably. Conceptually, this would allow smaller city rental agencies to cycle rental stock to larger cities for auction and replacement while also supporting downtown automobile rental agencies near to a station that are in turn needed for allied convention and visitor traffic at nearby hotels and eateries.

In this way a prospective intercity traveler could enter a city to city zip code search and get actual priced results that combine the flexibility of an automobile for shorter distance daytime driving with productive non-driving time over the longer middle segment as an intercity rail passenger. Ideally, such pricing would also include group insurance coverage.

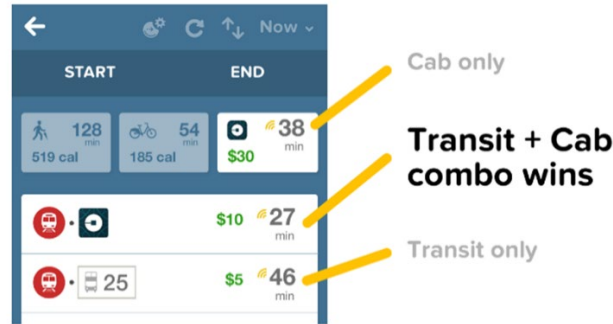

Image of Integrated Automobile (Self Driving, Cab, or Ride Share) and Transit trip planner Courtesy of [Citymapper](#)

Station franchises could also serve as a means to reduce direct operating cost while making the station area more attractive. Examples of this are combined coffee shop, express package pickup, and operator neutral rental car locations, all Amtrak branded under a franchise type arrangement. The physical passenger platforms adjacent to the tracks would still remain the responsibility of NRPC due to their special railroad construction, design, and maintenance requirements.

Operations Analysis

Attributes of a Fixed Investment Operator

Within the context of the United States Department of Transportation, Federal Railroad Administration (FRA) Long-Distance Service Study, the study routes presented to date outline a great opportunity to serve citizens in our interior cities but the remaining study effort must propose improved financial and governance metrics for these routes. The existing paradigm of placing fixed and variable costs in one bucket, then seeking to minimize the bucket’s total cost, hamstringing efforts to achieve true efficiency on a per person-mile traveled basis found in following declining Long-run Average Cost curves towards greater capacity and service.

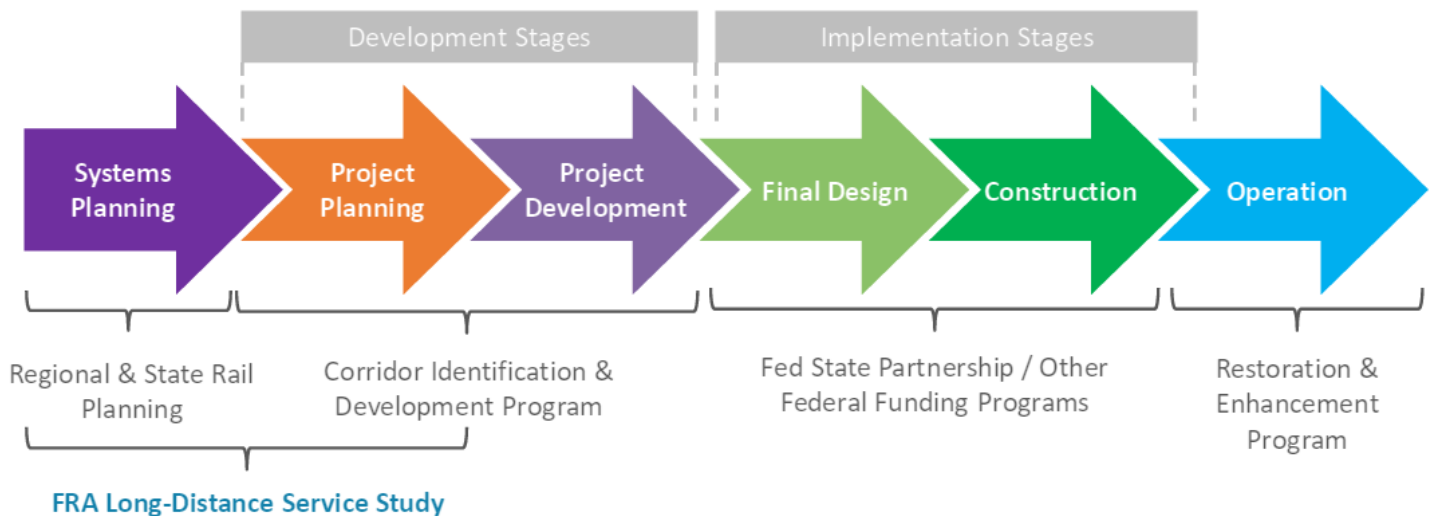

FRA Long-Distance Study / Corridor ID Program, 7-14 Year Long Series-Step Approval Program

Design engineers examining alternative project designs understand that dollars are fungible between capital and operations using a discount rate, however there is always the temptation to “capitalize” ongoing items. Transportation Secretary Volpe’s original 1970 plan for Amtrak⁵⁶ relied on future Federal capital for high-speed corridor routes which could in turn float an operational gap for reduced national routes. Thus no annual funding was provided equivalent to the rate of Interstate Highway leveraging atop excise (gas) taxes on the use of locally funded streets. This was prior to the Reagan era change in capital policy when Federal annual funds were first provided to support re-paving maintenance. Trying to parse between capital and operations of common infrastructure eventually leads to problems.

What happened thereafter was likely a focus on the Northeast Corridor after a 1973 Penn Central bankruptcy court ruling that Amtrak was the majority user of the Northeast Corridor⁵⁷, hence responsible for the majority of the costs as well as various reform concepts from the USDOT that focused more on short corridors fitting the congestion relief model⁵⁸ and less on demonstrated consumer demand leading up to the 1979 route cuts. Likely the general rise in violent crime in large cities from the mid-1970’s to the late-1980’s also suppressed ridership though it is difficult to break this effect out entirely. Further, restoration of large stations such as Washington Union Station also bring about increased ticket sales.

⁵⁶ Library of Congress - Congressional Research Service. "Amtrak Profitability: An Analysis of Congressional Expectations at Amtrak’s Creation." 2002. <<http://research.policyarchive.org/1446.pdf>>

⁵⁷ ICC 342 Finance Docket 27353. Trustees of the Property of Penn Central Transportation Co, Debtor - Compensation for Passenger Service. 1973. <<https://babel.hathitrust.org/cgi/pt?id=mdp.39015024020268;view=2up;seq=2>>.

⁵⁸ Runte, Alfred. "The Last Train To Grand Canyon: How Amtrak Fails The National Parks—And America." 2018. <<https://www.nationalparkstraveler.org/2018/08/essay-last-train-grand-canyon-how-amtrak-fails-national-parks-and-america>>.

Obviously, the slower National Network Long Distance routes incur greater operating labor costs but equally as obvious the faster Northeast Corridor routes incur greater infrastructure cost.

To the extent that operational numbers, such as the leftmost beige portion of the chart below, are presented for Amtrak business lines excluding reoccurring infrastructure costs, the analysis is incomplete. Recent letters from Amtrak to support their focus have excluded around \$1.57 Billion in infrastructure Route Costs that when apportioned by areas of infrastructure ownership, as on the rightmost green chart portion, demonstrate a sustained need for investment for the NEC core. The operational numbers are confusing when what are really capital leases to use the shareholder owned railroad lines are termed operating instead of infrastructure costs. To downgrade onboard amenities contributing to Time-Utility in order to meet these definitions is counterproductive particularly when the relative rates of investment are considered by passenger-mile metrics.

“Buying time” through either higher speed infrastructure or amenities that allow for increased Time-Utility while en-route should be equally considered at the Federal level according to an Average Cost metric that considers both capital and operations as fungible dollars when converted to annual equivalents using a discount rate.

Route Operations in Amtrak's Business Lines stated by Amtrak's definition of Operations that largely excludes NEC Infrastructure but includes Infrastructure for the National Network					All Business Lines (Including Ancillary, Commuter Access, and Carryover)
\$ Millions (FY2018)	Northeast Corridor	State Supported	Long Distance	Total Operations	
Adjusted Ticket Revenue	\$1,243.50	\$513.80	\$441.20	\$2,198.50	\$3,386.70
Food & Beverage Revenue	\$45.60	\$25.70	\$69.40	\$140.70	
State Funding	\$0.00	\$233.80	\$0.00	\$233.80	
Other Revenue	<u>\$26.80</u>	<u>\$15.00</u>	<u>\$12.80</u>	<u>\$54.60</u>	
Operating Revenue	\$1,315.90	\$788.30	\$523.40	\$2,627.60	
Operating Expense	(\$791.80)	(\$879.40)	(\$1,066.70)	(\$2,737.90)	
Adjusted Operating Earnings	\$524.10	(\$91.10)	(\$543.20)	(\$110.20)	
Ridership	12,123,643	15,079,135	4,513,474	31,716,252	

Amtrak Operations Centered Presentation using semi-EBITDA⁵⁹ for FY2018 and Gap in All Business Totals

Amtrak has long sought survival in a federal policy blind to highway trust fund leveraging, reporting Route level Operational Earnings in the red chart that largely exclude 1 ½ Billion⁶⁰ of NEC annual infrastructure costs⁶¹. While the NEC is treated consistent with highway and aviation policy the National Network should be treated similarly with costs parsed between Below-the-Rail Infrastructure and Above-the-Rail Operations there too so as not to assign as

⁵⁹ EBITDA is currently in vogue - Earnings before Interest, Taxes, Depreciation, and Amortization - but is somewhat incomplete when infrastructure is involved as it strips out the cost of capital investments like property, plant, and equipment when owned but not when expensed to operations hence the call for a clear division between infrastructure and operations to find a balance between capital and expense work

⁶⁰ The infrastructure cost for just the NEC and NEC Branches is roughly \$1.5 billion annually of Amtrak's \$1.9 billion in Below-the-Rail infrastructure costs, comprised of Infrastructure Asset Line - Steady State Program costs of \$374 million for Track, \$424 million for Bridge and Building, \$97 million for Electric Traction, and \$111 million for Communication and Signaling from: Amtrak, Five Year Infrastructure Asset Line Plan, FY2020 to FY2024, 2019. <<https://www.amtrak.com/content/dam/projects/dotcom/english/public/documents/corporate/businessplanning/Amtrak-Infrastructure-Asset-Line-Plan-FY20-24.pdf>>. To this value is added an estimated \$500 million NEC portion of facilities infrastructure support, station, risk, policing, and environmental that is logically Below-the-Rail infrastructure from the APT breakdown in Appendix C.

⁶¹ “Part of the reason that services on the Northeast Corridor appear more profitable... is Amtrak treats a significant portion (60 percent) of the cost to maintain track in the Northeast Corridor as fixed cost and therefore excludes them for the measures of avoidable (Ed. Operations) costs.” US Government Accountability Office, "Financial and Operating Conditions Threaten Amtrak's Long-Term Viability", 1995.

<<https://www.gao.gov/products/RCED-95-71>>.

operational costs⁶²⁶³ the infrastructure costs for shareholder owned track or public terminal use. Allocating fixed infrastructure costs to routes obscures resource efficiency. This explains why cutting around 33% of total and 50% of long-distance train-miles was estimated to generate but 10% operational cost savings and little capital savings⁶⁴.

Reorganizing in a Below-the-Rail Infrastructure and Above-the-Rail Operations manner would have Amtrak’s Long-Distance - Route Variable Costs covered as infrastructure investment, freeing prices to reset and efficiently grow volumes⁶⁵ to dilute operational fixed costs, setting the stage for consumer revenue to cover Above-the-Rail operations and equipment costs with only minor local (station area) sponsorship of station buildings and crossings. Importantly with such an arrangement the operator would have a very good shot at a profit - giving motive to advance service innovation and delivery - as the infrastructure costs would be borne in the same proportion as highways.

Est. Person-Miles (Millions)	1984	1920	2616	6,520	Per Analysis of FY18 APT cost centers, Amtrak actually spent in Below-the-Rail Facilities Infrastructure about \$1,925 Million vs. \$2,185 per FY18 Financial Report
Est. Train-Miles (Millions)	8.970	12.600	14.341	35.91	
Est. Operations Expense (Above-the-Rail) Only	\$629.8	\$327.6	\$372.1	\$1,329.5	
Equipment Capital-Depreciation (Above-the-Rail)	\$233.1		\$193.9	\$427.0	
Reimb. Equipment Capital-Depr. (Above-the-Rail)		\$128.3		\$128.3	
Est. Variable Infrastructure & Risk (Below-the-Rail)	\$498.7	\$78.1	\$88.9	\$665.7	
Est. Fixed Infrastructure & Eng. (Below-the-Rail)	\$1,001.3	\$138.6	\$157.8	\$1,297.7	
Est. Long-Run Infrastructure (Below-the-Rail)	\$1,500.0	\$463.4		\$1,963.4	
Common Costs (Allocated from Corporate)	\$337.3	\$206.8	\$254.0	\$798.1	
Est. Total Federal Investment at Low Volume Ops.	\$1,384.3	\$91.1	\$543.3	\$2,018.7	

Extended Fungible Capital and Operations Analysis of FY2018 Amtrak to find true Resource Efficiency

Amtrak as a P3 Vehicle Operator

Nothing should prevent a sub-entity of Amtrak from bidding to be the Above-the-Rail Vehicle Operator under the Interstate Competitive Corridor Capacity P3 grant discussed in the next section. But to do so the Amtrak sub-entity would need to financially separate out operations for the sub-entity per the infrastructure operator and vehicle operator divisions needed to ensure competition and provide reimbursement to the parent company for existing vehicle depreciation and terminal costs at the same rate offered other competing Above-the-Rail Vehicle Operators. This amicable solution can be found for Amtrak as nearly all of the FY18 & FY19 federal grant actually went to the green highlighted Below-the-Rail facilities infrastructure, security, and risk costs seen in the chart above so there should be no financial burden.

Attributes of a Variable Investment Public-Private Partnership (P3) Operator

No level of FRA oversight will ever improve upon on-the-ground decision makers locally enabled to daily better service hence it is most desirable to create a contract structure that does so by means of a consumer centric feedback loop after the public infrastructure investments are made of a variable basis by train-mile operated.

⁶² “How Do Long Distance Trains Perform Financially?”, Amtrak, Accessed October 2020.

<<https://www.amtrak.com/content/dam/projects/dotcom/english/public/documents/corporate/position-papers/white-paper-amtrak-long-distance-financial-performance.pdf>>.

⁶³ Amtrak states - “15 long distance (over 750 miles) routes... receive a disproportionate share of Amtrak’s federal funding because they account for most of Amtrak’s operating losses (\$475 million in FY 2019) and the federal government is their only source of capital funding...” yet does not mention federal funding of unallocated NEC infrastructure costs of almost three times this amount – See: Amtrak, “Stakeholder FAQs”, Accessed 2020. <<https://www.amtrak.com/about-amtrak/amtrak-facts/stakeholder-faqs.html>>.

⁶⁴ Operational Expenses estimated to be \$3026 Million in FY21 versus \$3352 Million in FY19 with no change in Capital, “Amtrak FY2021 Supplemental Grant Request”. May 25, 2020.

<<https://www.amtrak.com/content/dam/projects/dotcom/english/public/documents/corporate/reports/Amtrak-FY2021-Supplemental-Grant-Request.pdf>>.

⁶⁵ Passenger trains have a declining average cost curve with respect to increasing volume on each train

This study should seek ways to support them as they seek the best production point at the intersection of the Consumer Price curve and Production Cost curve in a productive feedback loop. Only by devoting sufficient study effort now towards defining conceptual financial and performance governance metrics to meet the law’s SEC. 22214 (a)(5) identify Federal and non-Federal funding sources... including- (B) options for entering into public-private partnerships (P3s) ... could such a beneficial feedback loop be created.

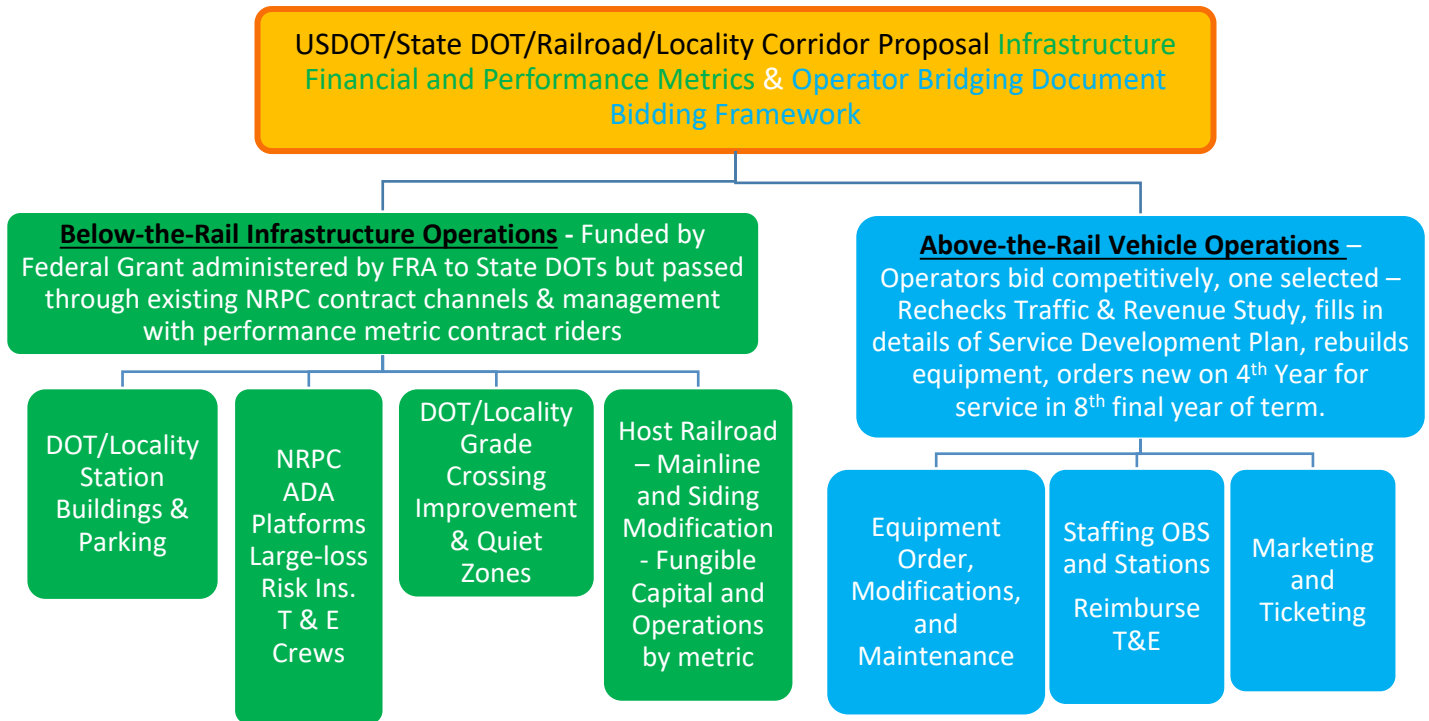

Proposed Interstate Competitive Corridor Capacity (ICCC), 2-4 Year Long Parallel Implementation Program
 Interstate Competitive Corridor Capacity (ICCC) Public Private Partnership (P3) Governance Structure
 To hasten new fuel-efficient service and provide for enhanced operations on a shared use railway corridor, a corridor grant framework is needed that relies on distance-traveled metrics to distribute annual Federal investments, applied to fungible infrastructure capital or operational shifts judged by enhanced performance metrics to guard public funds after which the consumer market finds the most efficient production point.

To obtain true resource efficiency on a shared-use railroad corridor, this grant structure would consider transportation of both persons and freight. Thus, the infrastructure improvements would be earned annually under the terms of the grant by existing and improved intermodal freight and industrial access carload freight operations according to performance metrics that support domestic industry and by new or improved passenger rail operations. In both cases, the funds would flow to the owner of the infrastructure. This can be done when funding is proportionate to the true highway cost gap that is unique United States in its size to allow for intermodal competition and rehabilitation of highways.

Separating Infrastructure Cost and Recognizing it to be Fixed under a P3 Infrastructure Operator:

This full SDP study should further define a separate Below-the-Rail Infrastructure Operator, who would remain the FRA through the National Railroad Passenger Corp. (Amtrak) with Federal investment flowing only to infrastructure, be it terminals, mainlines, risk, and boarding platforms and then distributed through to existing means to host railways with P3 contract riders. To do so the study should determine an average level of investment in railway infrastructure required – both capital and operational - using parametric freight and passenger shared mainline capacity curves, compare it to that

for highways, and propose a structure that treats all such Below-the-Rail expenditures as a fixed cost public investment with respect to train-miles operated except for large metro terminals.

Conceptually the P3 grant funding divisions would be structured so that all the Below-the-Rail P3 Infrastructure Operations (mainline access and terminal access, terminal platforms, large-scale accident risk coverage, and security) would be acquired through NRPC and funded by the Federal grant with seamless interregional connections that do not require a transfer between cars.

The alternative where a Capital Lump Sum value for upgrades to shareholder owned railway infrastructure is first sought may take years when contested by railroads trying to negotiate the best one-shot agreement as the delay performance metrics may be used to vary investment values massively. Instead, an amicable access agreement, according to shared annual freight and passenger infrastructure public funding metrics and delay performance, might be inked in months when the P3 has capacity funding, enabling engineers to then complete efficient designs within the framework.

Benefit to Cost Analysis (BCA) Includes both Freight and Passenger Benefits:

Using parametric average curves could allow for the BCA to include both freight and passenger benefits, avoiding the trap of trying to justify investments from passenger benefits alone which is like seeking to justify an Interstate Highway with only motorcoach passenger benefits. Notably by combining the two, that both need a resilient mainline, significant emission reductions benefits are had.

This comment reviews the financial reality of a significant Interstate Highway cost gap between incremental taxes and fees and the average costs to governments from original research. The same Long-Run Average Cost financial metric could guide both highway and railway programs in a future reauthorization to rebuild all infrastructure in parallel.

Providing Options for a separate P3 Vehicle Operator:

The statutory text can only be understood in terms of some type of P3 involvement with a vehicle and/or intermediate station operator. While this could be sub-division of Amtrak the new paradigm of removing the fixed infrastructure costs in proportion to the highway revenue to cost gap would allow whichever operator to fund vehicles, maintenance, consumables, and operations largely from Consumer revenue. Worked examples are included in this comment to demonstrate how this division or responsibility achieves better service to interior cities. These examples should be expanded upon in future stages of the study using Time Utility metrics not just Time Saved metrics to demonstrate this potential to Congress.

The P3 metrics proposed herein to achieve these goals have been described as out-of-the-box by industry insiders accustomed to lengthy reviews, clunky execution with no clear party driving forward, and overly complicated engineered plans that struggle to make the best use of superannuated infrastructure when operational changes might suffice. Importantly in must be noted that adopting the numerical simplifications and parametric approaches outlined in this comment would allow for a timely conclusion of the study and an actionable governance structure proposal to Congress.

With these relatively fixed infrastructure costs covered by the grant it would leave the Above-the-Rail P3 Vehicle Operations (equipment capital and leases, equipment maintenance, services, Train & Engine Operating Crews (Either NRPC, the host railroad, or Operator union personnel), consumables, small-loss slip-fall risk, and food service) to be funded from Consumer revenue and very minor local city station area sponsorship. The state DOT would be a party to the grant in the role of looking over contracts and serving as a Federal and City liaison. However, the designer of the service and equipment would be the P3 Vehicle Operator responding competitively to consumer revenue expressed in a desire for increased Time-Utility.

Proposed Definition of a P3 Structure for Further Study:

As part of the FRA study a P3 structure should be explored by producing for an example corridor a Service Development Plan, Financial Analysis, Economic BCA, and RACI Charts of the governance structure according to this outline.

Host Railroad – Still a Shareholder Owned Infrastructure Owner & Integrated Freight Operator

Same responsibilities but with contract riders on the existing NRPC agreements for performance metrics while receiving the P3 defined Financial Metric of \$21.0 per Train-mile of Intermodal Freight operated for first 800 miles operated between public terminals for each passenger train on the route.

- a) Contracts with Amtrak for Mainline Access under their Risk management and security plans
- b) Receives public investment to fund Intermodal Freight train infrastructure according to the P3. This spreads the required capital to upgrade mainlines into more resilient, higher performing networks and produces more public benefits noted in the BCA calculations.
- c) Agreement to operate overall network to 9 minutes of passenger train delay and 40 minutes of priority freight train delay per 100 train-miles performance metric or make investments.

NRPC dba Amtrak – Nationwide Below-the-Rail Passenger Rail Infrastructure Operator

Responsible for arranging, contracting, and managing Infrastructure Access funded by a Public Investment from Federal Grants or Public investments awarded through the Federal Railroad Administration according to the P3 defined Financial Metric of \$17.2 per Train-mile. This variable investment for the route is added to the existing fixed public investment in NRPC for large metropolitan terminals and Northeast Corridor mainlines.

- a) Host Railroad Mainline Access & NRPC Owned Mainline Access
- b) Terminal yard and daily servicing trackage - NRPC or Commuter Owned
- c) All ADA Boarding Platforms in Right of Way - Construction, Maintenance, and Operations
- d) Shared Multi-route Terminal Station Buildings – Construction, Maintenance, and Operations – retail leases
- e) Large-Loss risk insurance – Coverage for collisions
- f) Station Security - Emergency preparedness – Planning and Coordination
- g) Provision of Train & Engine personnel if requested – Reimbursed by Vehicle Operator

Route Operator – Railroad Selected under P3 Terms – Above-the-Rail Passenger Rail Vehicle Operator

P3 Team would be Responsible for arranging, contracting, and managing all Vehicle Operations using Consumer Revenue and minor State and Locality sponsorship. Competitively selected according to a State DOT/FRA process under the P3 Bidding Structure open to sub-entities of Amtrak with entirely separate financial reporting.

- a) Equipment design, program, capital funds or lease depreciation payment, and maintenance
- b) Fuel and Consumables
- c) Route Management
- d) On-board service personnel
- e) First-dollar risk insurance – Coverage for non-collision injuries and slip/falls
- f) Intermediate Station Building, Restrooms, Shops, and Amenities – the station area viability is dependent on the transportation service while ticket revenue also corresponds to the area quality – P3 coupling generates and captures community development value
- g) Train & Engine crews – Either reimbursement to Amtrak, Host Railroad, or direct employment
- h) Traffic and Revenue Estimates - prior to bid.
- i) Marketing, Ticketing, Revenue Collection, and Profit and Loss responsibility - post bid

Proposed Reinstated North Coast Limited/Hiawatha – Train Consist, Capacity, and Type

Premium Offerings have Significant Unmet Potential – Reservations Turned Away

On existing long-distance rail routes, there appears to be insufficient capacity to offer enough “stock” to bring in full-rate business or leisure travel booked in the one to four week interval closer to departure dates. SABER based corporate travel systems often block the National Network trains. For a full understanding of the market potential that has been turned away, a study of existing route phone requests and internet searches that go unmet for lack of available space should be included in a P3 RFQ to help set factors that would determine the planned train capacity.

As an example of a higher capacity multiple market segment train operation, consider in 1973 the Amtrak *Southwest Chief* route often operated at an 18-car train length⁶⁶, employing six double-deck coaches and six single-level sleepers featuring 45 private bedrooms, for a total capacity of 556 persons, with two lounge cars and two dining cars, compared to 318 persons capacity today with only 14 premium revenue private bedrooms. The train also exchanged through cars in Kansas City for eastern travel, building revenue in the middle segment.

Yet Amtrak was able to raise fares for this service in 1973 and came the closest they ever have toward revenue covering all of the total Capital and Operational cost of any route, even the NEC, requiring only around \$9.0⁶⁷ (\$2018) per train-mile of investment on a cost plus 5% contract then to the host railroad to operate the service, half the equivalent highway public investment rate when converted to an average trainload of people.

The Northern Pacific Railroad operated the *North Coast Limited* with a capacity for 250 coach seats and 82 sleeping car berths in a 14-car train. The addition of a Slumbercoach added 40 coach-sleeper berths starting in 1959. To staff the train, there was a 5-person Train & Engine crew, baggage handler, 2 postal clerks for sorting mail enroute, 3 coach attendants, the Stewardess-Nurse, the 3-person Traveler’s Rest lounge crew (cook, waiter, and waiter-in-charge), the 10-person dining car crew (steward, three cooks, and six waiters), the Pullman (private room sleeping car) conductor, 5 Pullman porters, and the Pullman Observation lounge attendant. In addition to these 30 employees who traveled the route, exempting the postal clerks, a traveling electrician/mechanic frequently rode back and forth on the midpoint of the route for troubleshooting and the train stopped for inspections several times along the route.⁶⁸

The point of considering the historical service is to try to replicate the amenities that kept the *North Coast Limited* and its companion daily train the *Mainstreeter* running until the beginning of Amtrak in 1971 but in a more efficient manner.

The 2009 Amtrak study that considered the restoration of the *North Coast Hiawatha* used (6) trainsets made up of 2-3 diesel locomotives, and 9-cars; a 1 baggage car, 1 transition crew car, 3 bi-level coaches, 2 bi-level sleepers, 1 sightseer bi-level lounge, and 1 bi-level diner. The total capacity would be 384 people in this configuration. Notably absent was a high proportion of higher revenue Room Sleeper accommodations as only 20 people would be accommodated in Bedrooms offering full ensuite bathroom though those accommodations often sell out far in advance.

In this sketch-level P3 SDP, the Above-the-Rail Vehicle Operations section has particulars of the proposed equipment but a summary is given here. In order to be conservative the train was modeled as single level equipment but in order to be competitive only 5 trainsets were figured for each train pair and a spare of each car type was assumed. This closely tracks with the pre-1971 private railroad operation with 5 trainsets and a fast turn around at the end terminals.

The Reclining Coach and Flat-Pod Sleeper car types are actually the same carbody type and seating fixtures but with differing occupancy depending upon the service made possible by the convertible pod seating fixture. This car type

⁶⁶ Frailey, Fred. *Zephyrs, Chiefs & Other Orphans: The First Five Years of Amtrak*. 1977.

⁶⁷ USDOT. "Report to Congress on the Rail Passenger Service Act." 1973. (Before the 1974 USDOT allocation revisions added cost to long-haul routes it appears that the net was \$0.08 x 199 persons per train-mile = \$1.95 per train-mile in \$1973 - See Appendix F for more detail) <https://babel.hathitrust.org/cgi/pt?id=mdp.39015048060373;view=2up;seq=96>.

⁶⁸ The Vista-Dome North Coast Limited, William R. Kuebler, Jr., Osso Publishing Company, 2004

could be a short-observation dome car with the accessible sleeper room(s) on the lower level with a wheelchair lift connecting to the observation seating.

A single type of Room Sleeper is considered with all rooms having ensuite restroom and shower facilities to make them equivalent to a traveling budget hotel so as to garner higher revenue with all sofas facing the direction of travel and dedicated mattresses atop a folding bed frame as opposed to folding seat cushions with a padded duvet cover.

The Food and Beverage / Café car in the financial model is intended to be the same carbody type whether it is used as a café, lounge, or diner service with roller mounted appliances that could be exchanged in a shop. This car type would have observation windows in the seating areas which would allow with the addition of a single accessible bedroom to the car type for full access to amenities. Conceptually, this common Café, lounge, or diner could be a short-observation dome car with the accessible sleeper room(s) on the lower level with a wheelchair lift connecting to the observation seating. Thus, there are only three passenger car types conceptualized for the trainset and one semi-automated pallet shuttle baggage/express car type.

With a proposed 9-car consist, found to be the minimal level that would allow for the train to recover all the Above-the-Rail costs from consumer revenue, the train could accommodate 258 people, or 322 people if the Flat-Pod Sleeper function was not used but instead they were sold as Reclining Coach seats. Of this total 66 people would be accommodated in full ensuite bathroom Room Sleepers, more than three times those accommodated in Bedrooms in the 2009 study, generating higher revenue per train-mile. Further, this is the minimal sized consist.

Expanding the capacity beyond a 9-car train consist would generate higher net revenue as would additional express freight transportation. Since the P3 structure allows for vehicle capital to be funded from consumer revenue, such a beneficial expansion in train passenger capacity would occur with no additional funding through the grant.

Notably absent from the proposed operation is a transition crew car, as the operation is modeled with a step-on/step-off setup for the majority of the Onboard Service crew as noted next.

Proposed Reinstated North Coast Limited/Hiawatha – Operations

Estimated Ridership and Passenger Miles

The 2009 report estimated a ridership of 359,800 annual passenger which is taken to produce 248.6 million annual passenger miles and 234.9 million annual vehicle mile equivalents if the trips were by automobile. The conservative P3 assumed ridership is estimated as 392,542 annual passenger which is taken to produce 271.2 million annual passenger miles and 253.0 million annual vehicle mile equivalents if the trips were by automobile. These figures are merely representative of options and have not been correlated to the revenue model methods suggested but are significantly constrained to what would seem likely, as this route historically recorder ridership closer to the northern alignment which currently has a much higher ridership. For the purpose of the full SDP the methods to correlate Time-Utility consumer behavior should be explored with the bidders required to take on Revenue risk in the bidding process.

Onboard Service Bases – Through Staffed and Step-On/Step-Off Arrangements

One theory on the staffing challenge for these onboard service positions is that personal schedules of people have become so convoluted that spending a night away from home on a regular basis has a significant impact on the desirability of the job. For the service, the cost of providing lodging for employees away from a home base is significant if sleeping quarters are provided on the train in a transition crew car.

The financial model at the Minimum Operable Segment (MOS) capacity level, has 5 Onboard service employees staying onboard at all times during the trip. The intent is to have this be a completely flexible pool able to cross-cover work assignments from Reclining Coach and Flat Pod Sleeper to Room Sleeper and Café Food and Beverage service. There would be one senior position that would serve as a train steward. All of these employees would start at the initial

terminal and work to the mid-point of the route where they would meet the opposing direction train and return to their home base, yielding a two-night out assignment.

The financial model has 5 en-route crew bases for Step-On/Step-Off service positions primarily focused on meal time food preparation and coffee-shop service during the full-day trip in the middle of the route. They would conceptually start very early in the day, reverse direction at either the end-terminal or would meet the opposing direction train, and then would work till very late in the same day before getting off at their home base the same day. Such a schedule would allow for the maximum accumulation of compensated hours in a single day, would provide for simpler vacation scheduling, and would save the cost of onboard accommodations.

Something like this Step-On/Step-Off service positions arrangement existing on the private railroads for coach attendants until the network started to collapse. The conceptual bases for these employees are Chicago South Side, Fargo, Glendive, Paradise, and Yakima.

Service Interruption Turnaround Locations

In order to preserve the functioning of the majority of the route when delays occur the P3 RFQ would require the development of a plan to turn and service the train at Spokane or Minneapolis, with connecting motorcoach service provided to the end terminals that would not be served in this circumstance. Additionally, the operating plan would need to incorporate an emergency turn location near the mid-point of the route that would allow for service from one direction at least to the high passenger count Yellowstone National Park area.

Service Ramp Up – Joint Train Routing Options

During the initial 3-year ramp up of revenue that typically occurs with a new route it might make sense for the P3 to be constructed to allow for the option to operate the proposed service combined with Amtrak's Empire Builder over either the three hundred some mile western end from Spokane to Seattle/Portland or the six hundred some mile eastern end from Minneapolis/St. Paul to Chicago. Since the National Railroad Passenger Corporation (NRPC) dba Amtrak would be a party to the P3 as the Infrastructure Operator agreement on this type of joint cooperation might be worked out within the P3 RFQ creation process.



Western End Joint Possible Operations

Western End Routing

Longer term, it likely makes the most sense to keep joint operations on the western end of the route over the Spokane to Portland segment of the Empire Builder route as the proposed schedule would be close to the Empire Builder and the exact route is traced.

The financial model in this work assumes that only the Seattle leg exists for the new route and the Portland traffic would be an incremental addition to Net Revenue by means of a through car connection at Pasco. Even this type of joint operation would represent a savings to the Empire Builder operational costs.

In the future the Empire Builder could operate as a full service train to Seattle while the North Coast Limited / Hiawatha could operate as a full service train to Portland. Both trains could interchange through Room Sleeper and Reclining Coach cars at Spokane with each other to provide direct service to both cities. The route from Pasco to Seattle could be added as part of a possible Pioneer route heading to Salt Lake City directly.

Quickly adding or subtracting cars would require the expedited Head End Power switching options be provided on both sets of cars as detailed earlier in the Above-the-Rail Vehicle Operations section.



Eastern End Joint Operation and Possible Reroute with Feeder Motorcoach

Eastern End Routing

Longer term on the eastern end of the route it might make sense to use the historical routing shown in dark blue that would enter the Chicago commuter district near Aurora. The advantage of approaching Chicago from the west like this on a separate routing from the Empire Builder is it would expose new markets to the overall route and would allow for a short feeder motorcoach route shown in cyan to intercept 5 Intercity rail routes, each serving significant population centers as well as some un-served population centers.

Approaching the city using this infrastructure might be slightly faster than the existing route through Milwaukee to which the Empire Builder was rerouted once Amtrak took over operations. Another advantage to the Aurora route is the possibility to use METRA's 47th Street Facility under contract for maintenance activities during a lull in commuter train maintenance during the long layover required of the schedule on the western end of the route. The provision of daily maintenance at this facility would be provided as a lease under the Below-the-Rail Infrastructure Operator's terminal provision responsibilities.

An additional reason for using this route is it would very nearly approach a lot of the Chicago area package express and expedited trailer based express terminals midway between downtown Chicago and Aurora. Conceptually, adding trailer based express to the route could be facilitated with a block of express cars, complete with a leading locomotive, being added or subtracted at this location with a dedicated switching crew to make for a less than 5 minute pause at a suitable intermediate passenger station.

Schedule

No significant work has been done with the schedule relative to the 2009 Amtrak proposed for this Sketch-Level SDP.

NORTH COAST HIAWATHA Proposed					
Read Down	Mile	City			Read Up
11:15 AM	0	Dp	Chicago, IL	Ar	8:33 PM
11:39 AM	18		Glenview, IL	↑	7:50 AM
12:55 PM	86		Milwaukee, WI		6:45 PM
2:05 PM	150		Columbus, WI		5:35 PM
2:34 PM	178		Portage, WI		5:05 PM
2:52 PM	195		Wisconsin Dells, WI		4:47 PM
3:30 PM	240		Tomah, WI		4:06 PM
4:14 PM	281		La Crosse, WI		3:25 PM
4:50 PM	308		Winona, MN		2:49 PM
5:52 PM	371	↓	Red Wing, MN		1:32 PM
7:31 PM	417	Ar	St. Paul-Minneapolis, MN	Dp	12:28 PM
8:11 PM		Dp		Ar	11:48 AM
9:40 PM	482		St. Cloud, MN	↑	9:57 AM
10:42 PM	548		Staples, MN		8:48 AM
11:38 PM	610		Detroit Lakes, MN		7:49 AM
12:40 AM	658		Fargo, ND		6:52 AM
1:43 AM	716		Valley City, ND		5:34 AM
2:20 AM	750		Jamestown, ND		4:55 AM
3:48 AM	852		Bismarck, ND		3:20 AM
4:08 AM	857		Mandan, ND (CT)		3:07 AM
5:00 AM	957		Dickinson, ND (MT)		11:55 PM
7:05 AM	1063		Glendive, MT		9:54 PM
8:25 AM	1141		Miles City, MT		8:34 PM
9:20 AM	1187		Forsyth, MT		7:32 PM
11:13 AM	1288	↓	Billings, MT		5:52 PM
1:26 PM	1404	Ar	Livingston, MT	Dp	3:34 PM
1:54 PM		Dp		Ar	3:06 PM
2:36 PM	1429		Bozeman, MT	↑	2:00 PM
4:31 PM	1527		Helena, MT		12:06 PM
7:33 PM	1646		Missoula, MT		9:28 AM
9:39 PM	1717		Paradise, MT (MT)		7:08 AM
11:15 PM	1836	↓	Sandpoint Lt. ID (PT)		3:48 AM
12:42 AM	1904	Ar	Spokane, WA	Dp	2:30 AM
1:02 AM		Dp		Ar	2:10 AM
4:07 AM	2049		Pasco, WA	↑	11:25 PM
5:57 AM	2139		Yakima, WA		9:43 PM
6:57 AM	2175		Ellensburg, WA		8:35 PM
7:47 AM	2277	↓	East Auburn, WA		5:58 PM
10:42 AM	2300	Ar	Seattle, WA	Dp	5:20 PM

Proposed Timetable from 2009 Amtrak Service Plan

Station and Access Analysis

Terminal and Shared Intermediate Stations and Daily Servicing Yards

For these stations and terminals already in use by NRPC the intent is for the route operations to contribute to an incremental portion of the costs but not change the ownership model. To do so, a portion of the federal public infrastructure investment earned by the P3 route operations is directed to cover the cost of Operations and Capital in a fungible manner. The facilities for turning trains used for the long-distance routes are to be provided from this investment, similar to the way the federal funds cover the costs of the ramps and tarmac near to the gate that are used for airliner turning maintenance. This is necessary as these facilities will always be shared due to commuter and long-distance operators using the same terminal area.

Below-the-Rail – Federally Funded – Servicing Facilities, Boarding Platforms, Risk, and Security

1. Existing Servicing Facilities for daily maintenance and restocking – NRPC or Commuter Owned
2. Existing Platform Rebuilding and Maintenance
3. Railroad Protective Insurance - construction and occupancy within railroad right-of-way.
4. Railroad Police – All common areas

Here the existing amenity building operator and owner will remain the same for the terminal area, but due to the shared nature of operations many different types of services use the same area. The intent is the owner to be able to strike commercial leases for food and beverage, retail, parking, and office space to fund the operations and capital needs of the building.

Above-the-Rail – Retail and Office Tenant and State Funded – Station Building and Operations

1. Rehabilitation of historical stations buildings – Matched with any other State or Federal grant program.
2. Construction of New station buildings – Matched with any other State or Federal grant program.
3. Utilities, Cleaning, Maintenance, and Employee Facing Staffing of Station buildings.

Conceptual Terminal and Shared Intermediate Stations and Servicing Yards – Financial Plan

The budget would be the amount remaining after the provision of the new Intermediate Station Below-the-Rail – Boarding Platforms, Risk, and Security, which are budgeted at \$2,799,262 annually as seen in the next section. Thus, the annual budget for the Terminal and Shared Intermediate stations funding would be \$10,639,016, which would cover the incremental costs of using the large metropolitan area stations in Chicago, Minneapolis/St. Paul, Seattle, and Portland as well as a portion of the costs for existing stations to be shared by routes.

Intermediate Stations – Route

For these stations that are exclusive to the route, the platforms, lighting, security features, and canopies in the railroad Right of Way will be the responsibility of the Below-the-Rail Infrastructure Operator and funded by the public investment per train-mile as will platform security patrols, provided by off-duty locality law enforcement.

Below-the-Rail – Federally Funded - Boarding Platforms, Risk, and Security

1. Concrete Paved Platform – 8 feet x 340 LF x 8” above railhead, illuminated at 35 Foot Candles, inclusive of sealed design and approval with railroads and locality.
2. Railroad Protective Insurance - construction and occupancy within railroad right-of-way.
3. Locality Police - (2) sworn officers, 1 Hour patrol of platform area, 45 minutes before arrival and 15 minutes after

All agents selling tickets and the cleaning and deicing of the platforms will be the responsibility of the Above-the-Rail Vehicle Operator. This arrangement is like that of a publicly owned airport and airline.

Any station buildings providing amenities such as a waiting room, restrooms, or retail space will be provided by a partnership with the Above-the-Rail Vehicle Operator and the locality. This will allow for the common practice of cities using historic stations for community functions while providing an incentive for these amenities to be open to passengers while allowing for the P3 coupling to generate and capture community development value around the station area. This coupling is important as the station area viability is dependent on the transportation service while ticket revenue also corresponds to the station area quality.

Above-the-Rail – P3 Operator and Locality Funded – Station Building and Operations

1. Rehabilitation of historical stations buildings – Matched with any other State or Federal grant program.
2. Construction of New station buildings – Matched with any other State or Federal grant program.
3. Utilities, Cleaning, Maintenance, and Staffing of Station buildings.

Conceptual Intermediate Route Stations – Financial Plan

The stations listed below are not necessarily the final selections but were previously mentioned in Congressionally funded studies performed in 2009 by Amtrak.

	Staffing - Hours per Day		Infrastructure		Amenity Building				
	Security	Agent	Platform	Canopy	Restrooms	Waiting	Food	Car Rental	Parking
Valley City, ND	4		X	X					
Jamestown, ND	4		X	X					
Bismarck, ND	4	8	X	X	X	X	X	X	X
Mandan, ND	4		X	X					
Dickinson, ND	4		X	X					
Glendive, MT	4	8	X	X	X	X	X	X	X
Miles City, MT	4		X	X					
Forsyth, MT	4		X	X					
Billings, MT	4	8	X	X	X	X	X	X	X
Livingston, MT	4	8	X	X	X	X	X	X	X
Bozeman, MT	4	8	X	X	X	X	X	X	X
Helena, MT	4	8	X	X	X	X	X	X	X
Missoula, MT	4	8	X	X	X	X	X	X	X
Paradise, MT	4		X	X					
Yakima, WA	4		X	X					
Ellensburg, WA	4		X	X					
East Auburn, WA	4		X	X					
Totals:			17	17	7	7	7	7	7

Platform Capital Cost Each \$1,300,000
 Canopy Capital Cost Each \$200,000
 Amenity Building Capital Cost Each \$4,000,000
 Annual Cleaning and Deicing Cost Each \$11,000

Below-the-Rail Infrastructure Operator			
Annual Security Cost	\$942,811		
Annual Platform Cost	\$1,608,924	Platform Capital	\$22,100,000
Annual Canopy Cost	\$247,527	Canopy Capital	\$3,400,000
Annual Total	\$2,799,262		

Above-the-Rail Vehicle Operator			
Agent Cost	\$776,433		
Annual Platform Cleaning and Deicing	\$187,000		
Annual Amenity Building Cost	\$2,038,456	Building Capital	\$28,000,000
Annual Car Rental Agency Rent	\$ (504,000)		
Annual Coffeeshop Rent	\$ (672,000)		
Annual Restaurant Rent	\$ (924,000)		
Annual Common Utilities	\$84,000		
Annual Total	\$985,889		

Below-the-Rail Infrastructure - Conceptual Engineering, Capital, Operations, and Maintenance

Proposed Railway Infrastructure Investment Rate Equal to Rural Interstate Highways

The proposed long-term total level of Below-the-Rail investment in this paper is slightly less than the leveraged Interstate Highway investment derived from taxes on the use of locally funded streets noted in the Alternatives section.

The National Railroad Passenger Corporation (NRPC) dba as Amtrak, as the P3 Infrastructure Operator would distribute funding to Host Railroads under resilient performance requirements (delay minimization, reductions in un-planned stops, safety, equipment and track inspections, etc.) with compensation under the P3 agreement earned on a financial basis per operated train-mile.

Instead of a grant determining one Capital Lump sum value up front the annual distribution of the financial compensation as a long-run average of that same Capital Lump sum would preserve the carrot in the P3 arrangement indefinitely, allow for flexibility as business needs change, and allow for operational changes to be made in a fungible substitution for capital expenditures to enable service to start sooner.

In order to implement this future hybrid transportation project funding structure, the 50-year USDOT embargo by guidance, where grants for capital and maintenance of existing intercity railroad infrastructure are routed through a lengthy BCA grant approval process but highway 4R funds are programmatically distributed, needs to be removed for both intercity freight and passenger rail infrastructure funding.

It is up to the USDOT to revise the guidance upon which Congress relies, particularly the BCA Modal Diversion commentary on Price-Demand curves, were no nationwide highway net capital and maintenance deficit is noted. Instead the guidance obliquely notes *“the generalized costs for using the competing alternatives from which an improved facility draws additional users are already incorporated in the demand curve for the improved facility or service.”* But if incremental user fees were increased to eliminate the net capacity financial cost, the demand for highway travel would decline, as has been seen when gasoline prices spike, affecting economic models. As highway projects suppress the market clearing freight and passenger price, pure toll highways for congestion management become nearly impossible except at bottlenecks. The simplest nationwide solution, absent a true market price, is to include a highway incremental financial cost reduction benefit in rail project BCA economic models.

Since this is a financial funding metric, the uncompensated costs of automobile accidents would be included in the sum.

Sketch-level P3 Service Development Plan – Conceptual Engineering, Capital, Operations, and Maintenance
 Interstate Highway Cash Flow Analysis used to Calculate Equivalents per Train-Mile

		NPV AAA Corporate Bond Rate	NPV 1-YR Treasury + 1% Rate	NPV Investor WACC Rate
Fee Gap per Total VMT		\$0.087	\$0.036	\$0.197
% Fuel Tax Rate		293%	121%	668%
Gap per Route Mile		\$35,274,130	\$23,503,822	\$129,222,504
Truck (N-1) Prorate	Additional funds per VMT to make up Gap - add to existing fuel fees			
Total Cost Ratio				
Automobile	100%	\$0.064	\$0.024	\$0.093
Class 8 Truck	400%	\$0.256	\$0.095	\$0.370
Rural-Urban Cost Assignment	\$2018 Adjusted Route Gap by Ownership Method (No Cost-VMT elasticity)			
Rural	170%	\$0.109	\$0.040	\$0.157
Urban	56%	\$0.036	\$0.013	\$0.052

Chart of Analysis of Six-Decades of Interstate Highway funding⁶⁹ to Determine Public Net Financial Cost

Calculating the Equivalent Public Infrastructure Investment per Train-Mile from Interstate Highway

- The proposed fixed rate for intercity rail is equivalent to the hard-dollar, leveraged Interstate Highway investment of \$0.109 per rural automobile vehicle-mile, resulting from taxing the use of locally financed streets then directing the funds narrowly toward highway type projects. This infrastructure portion is the same as the **Economic BCA Highway Net Incremental Capital and O&M metric**.
- To the infrastructure value is combined with the publicly borne accident financial costs of \$0.025, for an equivalent \$0.134 per automobile mile. While these values are expressed to several significant digits, the reality is this calculation is backward looking to 2018 and subject to likely a +/- 30% uncertainty as rural mileage has changed. The full P3 SDP should recalculate these values for the years of expenditure and have a third-party verify the methods.
- To convert this to a person-mile equivalent a 1.4 average automobile occupancy is used combined with a 180 passenger per train-mile average for a total of \$17.2 per equivalent train-mile in \$2018. The proposed funding rate is thus \$16.0 per train-mile plus the internal funding by a \$1.2 per train-mile set aside of FRA/NRPC large loss liability pool derived from a budget rate of \$0.007 per passenger-mile, even though this is a trailing metric. Many long-distance routes often in the near past exceeded this number of average passengers per train-mile until recent revisions to limit passenger car capacity were implemented. It is important to note that new build Interstate Highway type projects far exceed the original system’s average investment requirements proved over six-decades.

Note however, that this financial infrastructure investment metric does not count the substantial accident cost savings accruing to persons who would otherwise drive along the route, around half of all current riders. The otherwise

⁶⁹ Payne, Virgil, “Reforming Surface Transportation for Long-Term Sustainability”, Competitive Enterprise Institute, Issue Analysis 2020 No. 10, November 2020. <https://cei.org/news_releases/report-urges-reforming-surface-transportation-for-long-term-sustainability/>

uncompensated total economic value of lifetime losses from accidents and lost wages is around \$0.11 per rural automobile vehicle mile in \$2018, for which there is no program but Social Security Disability to financially actually pay a portion.

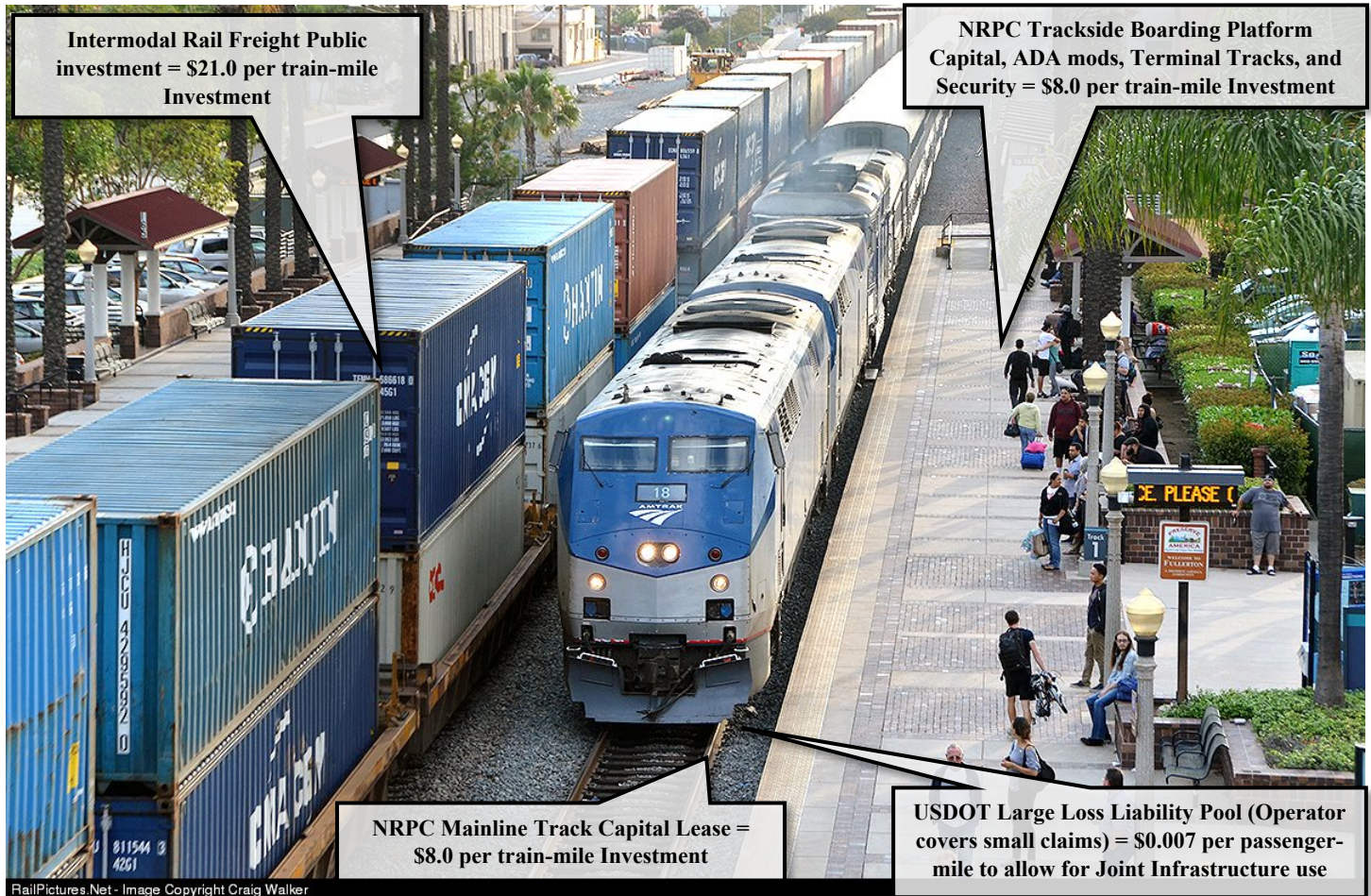

Illustration of Proposed Components of Investment – Image Copyright Craig Walker

To check the relative rates of charges for below-the-rail facilities infrastructure on a mixed intercity and commuter railroad it is helpful to look to the EU countries. Due to historical reasons the automobile fuel tax is around ten times that in the United States, which tends to set the market at a closer point to equilibrium.

Market segments for long-distance passenger rail services	Charges for long-distance passenger rail services, in EUR, per train-path kilometre	\$2018 DB Long-Distance train-mile Access Charges
Metro Tag min ($v \leq 100$ km/h)	5.33	\$9.5 for large city peak access (long- commuter)
Metro Tag max ($v \geq 160$ km/h)	12.17	\$21.7 for high-speed large city peak access
Basic	4.76	\$8.5 for typical intercity travel outside peaks
Nacht	2.67	\$4.8 for off-peak / overnight access

Summary Chart of Track Charges in Germany⁷⁰ - Operator and Infrastructure by Separate Companies⁷¹

⁷⁰ "The Track Access Charges 2020 of DB Netz AG." 2020, <https://fahrweg.dbnetze.com/resource/blob/1367430/7976d965d38a386f350dfd7f533a96f4/tpsbrochuere2018_en-data.pdf>.

⁷¹ Link, Heike. "Track access charges: reconciling conflicting objectives Case Study Germany." 2018. <https://www.cerre.eu/sites/cerre/files/180509_CERRE_TrackAccessCharges_CaseStudy_Germany_Final.pdf>

Improved Rail Freight Operations on Shared Use Corridor

This P3 could be a time-limited trial of a recently proposed railroad mainline infrastructure Federal Public investment⁷² on a national scale for the entire General Railway System that did not make it into the current STP authorization.

Conceptually, on the freight side the seller and operator would still be either the host railroad operating their own trains or those of a connecting railroad by prior agreement. However, since the P3 Infrastructure Operator grant amount, based on the equivalent highway financial cost gap, is very near to the Long-Run Average Cost of adding new railroad infrastructure capacity it would serve to encourage the railroads to shift their length of haul offered into a higher volume market.

- The grant would seek to pay the host shareholder owned railroads for intermodal trains (those transporting highway trailers/containers by railroad) operated along the corridor by the train-mile at a rate equivalent to the Interstate Highway cost gap. This would incentivize improvements to the fluidity of the entire mainline infrastructure that also benefit passenger rail supporting a stable base needed for passenger trains.
- The primary freight performance metric of the grant would be a Minimum Level of Service (MLOS), potentially 40 Daily Averaged Freight Train Minutes of Delay per 100 Train-Miles⁷³, to measure fluidity by a single metric. This metric could apply to the entirety of the mainline run of through freight trains until cleared into off-mainline terminals, measuring daily averaged delay relative to a free-running speed while allowing for fungible tradeoffs between mainline free running time and terminal yard capacity.
- A large portion of the fuel savings, emissions, and CO₂ reduction would actually be on the freight side of the interstate capacity grant, but this would only be enabled under the shared goals of the grant for a more fluid mainline allowing the intermodal freight service to address a highway–convertible market eight times larger.

It is also important to note the role that shared urban commuter passenger rail infrastructure could have in reducing drayage trip distances as the economics of maintaining urban rail access are typically challenging. By having a high-performance, two-track, shared access path into a metro area, a connecting shuttle from the far distant container terminals could reach multiple metro area destinations so that a much shorter drayage trip could be had in a less congested direction for the motor carrier, representing a net benefit instead of a cost relative to over the road operation. The operation of the shuttle intermodal freight trains on commuter rail infrastructure could occur before the morning rush hour and after the evening rush hour.

⁷² See generally - Payne, Virgil, "Renewed Consumer Relevance of the General Railway System," Railway Age 1 June 2021, <<https://www.railwayage.com/news/renewed-consumer-relevance-of-the-general-railway-system/>>

⁷³ Conceptually an all-day average delay on fixed infrastructure even capable of junction priority of 60 Daily Averaged Freight Train Minutes of Delay per 100 Train-Miles is the difference between a free running average speed of 35 MPH and a delayed average due to meets and passes of 26 MPH typically seen in STB documentation; [(100 Miles / 35 MPH) – (100 Miles / 26 MPH) = 60 Minutes]. 60 Minutes of delay also appears to be the inflection point observed in the parametric capacity curves reproduced in the appendix. 40 Minutes would be a reasonable higher performance metric.

Parametric Capacity Curves for P3 SDP Grant Value for Money Analysis

While newer analytical capacity allows for the use of the Rail Traffic Controller (RTC) program for detailed analysis, parametric CTC Capacity Curves⁷⁴ provide a framework to visualize tradeoffs, demonstrating less freight train delay if corridor freight trains are simply shorter than most existing sidings and sufficient terminal and staging tracks be provided. Sometimes, the train delay starting point for capacity studies can be set rather high in the capacity models, near the inflection point in the curve slope. These curves could be used to show it be more beneficial for mainline sidings to be used to support through interstate freight movement as a public good instead of queuing outside terminals.

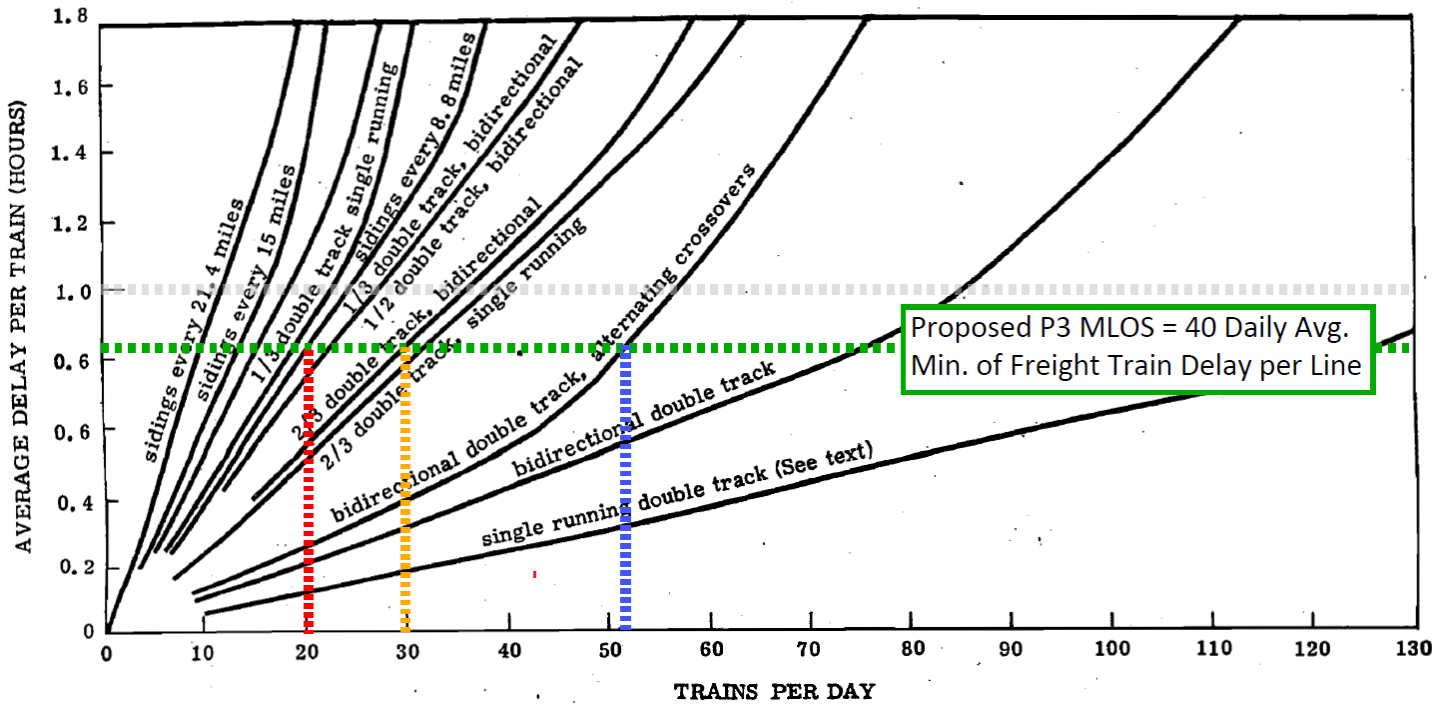

Chart of Train Volume – Average Delay Relationships for Alternative Configurations of 100–Mile Rail Line⁷⁵

The proposed P3 performance MLOS metric (Green Line) is no more than 40 Daily Average Freight Train Minutes of Delay per 100 Train-Miles is approximately shown as 20 Trains per Day (TPD) at 8.8 mile siding spacing, 30 TPD at around 6 mile siding spacing (2/3rds Double Track), and 52 TPD at bi-directional double track with crossovers. With sidings being defined as those that can take the train length. From the delay curve geometry, at the gray 60 Daily Average Freight Train Minutes of Delay per 100 Train-Miles higher minimum allowed delay metric, the slope of the delay curve slope increases indicating near network lockup from freight traffic alone. Ideally, the gap between 40 and 60 minutes is a reliability buffer.

Since the incremental payments per intermodal Train-mile operated are nearly equal to the incremental cost to add capacity all the way up the nearly the point of bi-directional double track with crossovers, the P3 provides a mechanism to fund privately held railway infrastructure without taking over the review and approval process for what specific annual improvements are made by the infrastructure owner, the host railroad. In the way the host railroad can implement improvements under existing NEPA Categorical Exemptions should the Federal Grant pre-clear this option with analysis.

⁷⁴ USDOT, Federal Railroad Administration, "Parametric Analysis of Railway Line Capacity," Figure 1: Train Volume – Average Delay Relationships for Alternate Configurations of 100-Mile Rail Line (Reproduced in Appendix), 1975, <https://railroads.dot.gov/sites/fra.dot.gov/files/fra_net/15031/FRA-OPPD-75-1%20Parametric%20Analysis%20of%20Railway%20Line%20Capacity.pdf>.

⁷⁵ USDOT, Federal Railroad Administration, "Parametric Analysis of Railway Line Capacity," Figure 1: Train Volume – Average Delay Relationships for Alternate Configurations of 100-Mile Rail Line, 1975

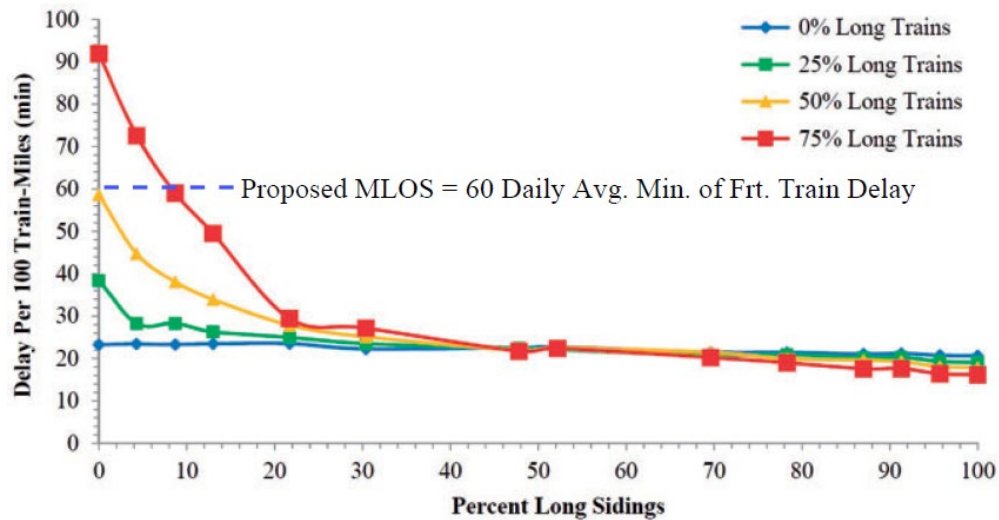

Chart of Average train delay for combinations of percent long trains and percent long sidings with 3:2 length ratio⁷⁶

In the case where the current infrastructure has almost no long sidings and is operating around 50% of trains of a 3:2 length ration (10,000 foot / 7000 foot) which intersects at the proposed MLOS metric of 60 Daily Average Freight Train Minutes of Delay per 100 Train-Miles. An alternate visualization would be various Train Volume vs Train Density per Mile curves, each run with differing percentages of trains longer than half the sidings, so as to illustrate the delayed average speed relative Capacity.

Domestic Intermodal Rail Freight - Container and Trailer-load Operations

In order to consider the effects of the proposed federal \$21 per intermodal freight train-mile public investment the following chart was prepared using a financial operations model that considered railroad and motor carrier cost structures. The model assumed 8000 foot trains, using conventional 53 foot double stacked crane lifted domestic container (DB-COFC) trains comprised of either 3-car articulated well sets holding 6 truck equivalent containers or conventional 53 foot crane lifted trailer (TOFC) trains using 5-car articulated spine sets holding 5 truck equivalent trailers. The analysis was conducted assuming the same net return to shareholders per train-mile for the use of infrastructure, an Operating Ratio target of 0.60 for the railroad operations to cover the cost of a network where supporting activities must occur, and a composite equipment borrowing rate of 8% for assumed new rail rolling stock.

It is important to note that significant investor driven restructuring of the railroad offered intermodal network has been unfolding, with the focus shifting to high-volume lanes where the existing equipment pool and terminals can be used fully, with minimal enroute switching to differing destinations, to command the highest net return. The proposed Public investment was designed so that it is entirely voluntary on the part of the railroads such that they could choose to operate so as to claim the credit using whatever equipment they choose or not, for any particular quarter or period as has been noted to be a concern⁷⁷ in such a partnership.

This is a significantly different position than past state grants to build only intermodal terminals or small sections of line, and as such it needs a multi-year, stable federal supporting structure. Guaranteeing future service to terminals or sections of line built by state or local agencies is a very difficult business decision to sign on to as a shareholder held

⁷⁶ Dick, et al, Relative train length and the infrastructure required to mitigate delays from operating combinations of normal and over-length freight trains on single-track railway lines in North America, Figure 1, Proc IMechE Part F:J Rail and Rapid Transit 0(0) 1–12, 2018, <<https://railtec.illinois.edu/wp/wp-content/uploads/Dick-et-al-2018-JRRT-0954409718809204.pdf>>

⁷⁷ Wilbur Smith Associates, Inc, et al. "Rail Freight Solutions to Roadway Congestion NCHRP Project 8-42 - ASSESSING RAIL FREIGHT SOLUTIONS TO ROADWAY CONGESTION." 2006. <http://onlinepubs.trb.org/onlinepubs/archive/NotesDocs/NCHRP08-42_FR_Rev10-06.pdf>.

railroad while reserving the right of future operational flexibility. This conflict leads to less innovation in terminal and railcar equipment design, which in turn negatively affects attempts to reduce the distance of drayage truck runs used to bridge between customers and railroad terminals as well as attempts to reduce truck urban highway congestion.

There are of course alternatives to providing railroads such an infrastructure public investment to restore market balance arising when commercial vehicles use Interstate Highways funded by the leveraged Highway Trust Fund that is in turn filled by excise taxes on the use of locally funded streets. One such alternative would be to create a new class of diesel fuel tax, with un-dyed diesel and its equivalents such as liquefied natural gas (LNG), required to be used for Class 3 trucks and larger but under a much higher tax rate to recover the noted investment gap in Appendix A so that the Highway Trust Fund is replenished. Then light vehicle diesel used in small vans and pickup trucks would use a new dye color or chemical marker to indicate use in Class 2 trucks and smaller at the existing diesel fuel tax rate. The existing untaxed, dyed agricultural diesel class would continue to exist, with the roadside test kits modified to detect conversions between the three classes.

This dyed diesel, three-class structure would be brutally efficient. But can a federal government really endorse such a shift when industries dependent on certain logistics strategies have been effectively told to invest in a certain pattern for more than three-quarters of a century? Perhaps, in the light of the alternatives, the railroad mainline infrastructure Public investment for just intermodal freight, convertible from highway movement, is actually much easier politically.

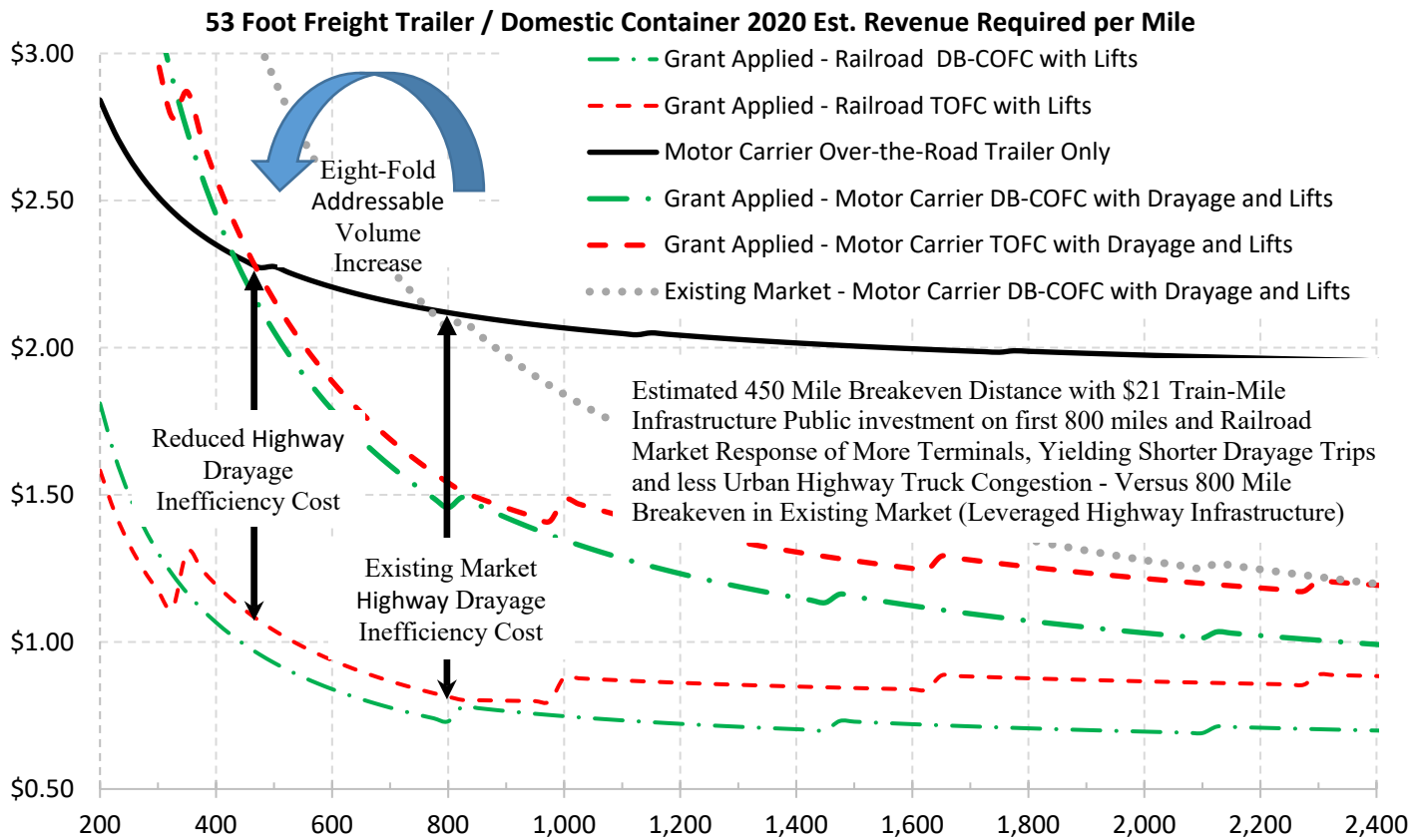

Chart of Intermodal Pricing showing Existing Market and Conceptual Pricing with Grant Applied for Infrastructure

The chart illustrates the important effect of drayage run lengths and the extra Motor Carrier operational cost needed to access intermodal freight terminals, represented by the entire area of the curves between the Railroad and Motor Carrier Revenue Required. Should an intermodal shuttle train be operated between say two business parks then this cost would nearly disappear, as the park's existing terminal truck tractors could pick up units and take them to

warehouse docks, leave them at the dock, and return for new loads nearly as quickly as when operating out of a trailer drop lot.

Route Characteristics

The chart below is based on the characteristics of the 2009 study with only a minor amount of effort to update the results as this would be done in a full SDP. The traffic composition on the middle of the route and the commuter district operations on the end of the route in particular need to be studied.

Route Characteristics			Existing Corridor Operations		Incremental Corridor Operations		Proposed Corridor Operations	
			Intermodal		Intermodal		Intermodal	
Railroad	Miles	Intermodal Freight Trains per Day	Passenger Trains per Day	Intermodal Freight Trains per Day	Passenger Trains per Day	Intermodal Freight Trains per Day	Passenger Trains per Day	
Chicago, IL to Rondout, IL	Metra	32	0	62	0	2	64	
Rondout, IL to Milwaukee, WI	CPKC	54	4	2	2	2	4	
Milwaukee, WI to St. Paul, MN	CPKC	331	4	2	2	2	4	
St. Paul, MN to Fargo, ND	BNSF	241	4	2	2	2	4	
Fargo, ND to Jones Jct. MT	BNSF	614	2	0	2	2	2	
Jones Jct, MT to Helena, MT	BNSF	253.6	2	0	2	2	2	
Helena, MT to Sandpoint, ID	BNSF	309.2	2	0	2	2	2	
Sandpoint, ID to Spokane, WA	BNSF	68.5	2	0	2	2	2	
Spokane, WA to Pasco, WA	BNSF	145.6	4	2	2	2	4	
Pasco, WA to Auburn, WA	BNSF	229	4	2	2	2	4	
Auburn, WA to Seattle, WA	BNSF	21.6	4	2	2	2	4	
Total Corridor Route at Hours		46	2299.5		50.0 Avg. MPH			

A significant advantage of a P3 arrangement with a variable public investment is details of the route and the particulars of what type of infrastructure is built or what type of operational changes are made are completely fungible. This feature allows for significant implementation efficiency and innovation in a second-best type of market offset by public investment.

Conceptual Below-the-Rail Route - Financial Plan

As to the level of influence of the \$21 per intermodal freight train-mile public investment, consider that the average infrastructure spending per mainline mile is about \$85,000 per year. If around twenty some freight trains are operated per day on a segment that indicates an average cost per train-mile of \$11. The shareholder required return of around \$95,000 annually per mile should be added to the average cost according to a prorated cost basis to obtain a total neutral basis of \$24 per train-mile.

However, the goal of the public investment is to encourage the expansion of fluid mainline capacity by adding sidings. Consider that a modern 16,000 foot long siding is probably going to cost around \$11 million to build. To place a new siding every 30 miles would require an additional \$5 per train-mile if the capital is annualized through bonds, much less if annual cash freed up by the public investment is invested to complete projects every year. In a shareholder led company it might be assumed that about half of the \$21 per intermodal freight train-mile public investment would be invested in otherwise new infrastructure, which would be enough to easily cover the extra \$5 per train-mile from the portion of intermodal trains on the route. Should the railway decide to not operate the service sensitive service it would simply not get the public investment, so an internal operations feedback loop exists with no need for regulator led metrics or claw-back agreements, nor those associated costs.

The addition of new sidings would increase the overall mainline railway capacity, leading to even lower average costs, thus promoting Public Good efficiencies for the overall economy, while leading to higher average speeds for all classes of rail freight and passenger traffic.

Sketch-level P3 Service Development Plan – Conceptual Engineering, Capital, Operations, and Maintenance

Interstate Infrastructure Operator Investment (Federal RAISE/ CRISI Grant)						
National Railroad Passenger Corporation (NRPC) - Pass Through Contract						
Below-the-Rail Infrastructure	Per Train-mile		Total	1,679,785 Train-miles		Runs per Day 2
Incremental Track Cost - Host Railroad	\$ 2.00		\$ 3,359,570			
Speed-Quality Track Cost - Host Railroad	\$ 3.00		\$ 5,039,354			
Special Connector Track If Req. - Host Railroad	\$ 3.00		\$ 5,039,354	(Or Actual Cost)		
Security and Large-Loss Risk Insurance	\$ 1.20		\$ 2,015,742	(Or Actual Cost)		
Terminals, Yards, Security, and Boarding Platforms	\$ 8.00		\$ 13,438,278	(Or Actual Cost)		
Total Below-the-Rail Passenger Infrastructure	\$ 17.20		\$ 28,892,298			
Host Railroad - Intermodal Freight						
Below-the-Rail Infrastructure	Per Train-mile					
Incremental and Speed Track Equiv.	\$ 21.00					
Total Grant Below-the-Rail Infrastructure Annual Investment - Incremental by Railroad						
	Freight	Passenger	Total	per Track-mile		Capital Equivalent RRIF Rate 30 Years
METRA	\$ -	\$ 116,880	\$ 116,880	\$ 3,653		\$1,814,068
CPKC	\$ 5,906,093	\$ 1,406,213	\$ 7,312,305	\$ 18,993		\$113,492,629
BNSF Midway/Staples/Jamestown/Dickinson/Forsyth	\$ 13,116,128	\$ 3,122,888	\$ 16,239,015	\$ 18,993		\$252,042,072
BNSF (Former MRL)	\$ 8,633,633	\$ 2,055,627	\$ 10,689,260	\$ 18,993		\$165,905,588
BNSF Kootenai/Spokane/Lakeside/Yakima/Stampede	\$ 6,797,376	\$ 1,618,423	\$ 8,415,798	\$ 18,993		\$130,619,698
BNSF Seattle	\$ 331,355	\$ 78,894	\$ 410,249	\$ 18,993		\$6,367,379
NRPC Special Connector Track If Required		\$ 5,039,354				\$78,214,675
NRPC Security and Large-Loss Risk Insurance		\$ 2,015,742				
NRPC Terminals, Yards, and Boarding Platforms		\$ 13,438,278				
Host Railroad Annual Mainline Infrastructure Payments			\$ 34,357,460	Annually		\$748,456,109
Total Below-the-Rail Infrastructure	\$ 34,784,584	\$ 28,892,298	\$ 63,676,881	Annually		\$988,314,446

This type of proposed public investment, when combined with a proposed categorical exclusion to National Environmental Policy Act (NEPA) reviews for work conducted on existing railway right of ways or on adjacent parcels less than one hundred feet wide when obtained with landholder consent even though traffic might increase, would enable the rapid infrastructure improvements the administration and legislature envisions. The overall full SDP and P3 grant approval process would be the planning vehicle to pre-clear NEPA categorical exemptions with sufficient public review, so that the P3 parties could proceed quickly, much as for highway P3 significant pre-clearances are performed.

Conclusion

For the MOS of a through routed intercity train corridor from Chicago to Seattle, the public freight annual investment would be \$34.8 Million and the public passenger annual infrastructure investment would be \$28.9 Million with benefits directly to at least six states. The economic analysis indicates that this would produce a Benefit to Cost Analysis (BCA) ratio that would justify federal tax funding.

These annual payments to the infrastructure owner are very close to the lump sum capital investment noted in the 2009 study when converted using a discount rate. However, since they could be used as cash in each year they would likely have more value as smaller projects could be completed one after the other as the need arises.

The flexibility of using performance metrics to govern the modifications to the existing infrastructure might allow for such a deal to be inked in months with all parties agreeing to it amicably and continuing to work toward the projects successful long-term implementation as if they did not the service would stop along with the annual public investments. This entire process would allow for innovative problem solving and the involvement of owner’s engineers and consulting engineers from several different parties all working together with a fixed goal in mind and governed by financial accountability through the grant’s performance metrics and funding indexed to actually providing a service to the public.

Above-the-Rail Vehicles – Procurement, Capital, Operations, and Maintenance

Absent sufficient revenue from different passenger accommodation tiers and express, a long-distance passenger train can be like a 4-engine regional jet, with high fixed costs and skimpy revenue per mile. How could the P3 structure hasten vehicle delivery to develop the capacity for these revenue streams?

Private Operator is At-risk for Timely Vehicle Service Entry Allowing for Minimal Reviews

Since the federal and state governments would not be leading the procurement or funding vehicles there should be a minimal review, comprised of ascertaining if the design is according to FRA performance regulations. The P3 operator would fund vehicle purchase and recapitalization from consumer revenue, With the P3 vehicle operator contributing 10% of junior equity toward the purchase or refurbishment of the vehicles, they would stand to lose the most, which should guarantee any federal interest in a RRIF loan to cover the remainder of the purchase. The overall P3 grant structure could also justify a 10% Buy America content waiver and provide a vehicle buy back option at the P3 term end to satisfy the RRIF loan remainder, yielding a functional vehicle mini-marketplace as in the EU.

General Passenger Equipment Improvements

In general the existing Amtrak Superliner car fleet was built with several departures from previous levels of comfort. Notably the lavatories were designed to mimic the smaller size of those on aircraft, even though space is not on a premium on trains to anywhere near the same extent. The sleeper rooms also reverted to essentially an economy bedroll atop seat cushions, instead of previously used thicker mattress for many accommodations. Both of these questions could be addressed in an interior rebuilding program to recapitalize the structural shells for an additional 21 years of service life with a developed plan to deal with 40 year inspections.

Another general improvement in the between car passageways, known as diaphragms, would be to seal the passageway with positive HVAC air pressure. In this concept, tapered engagement lugs at the joint in the walkway would align the seal while lateral shock absorbers between car bodies and the mating surface would reduce body roll. This sealed passageway would eliminate the need for opening end car end doors, increasing the comfort for less mobile travelers, while reducing dust, noise, and door maintenance.

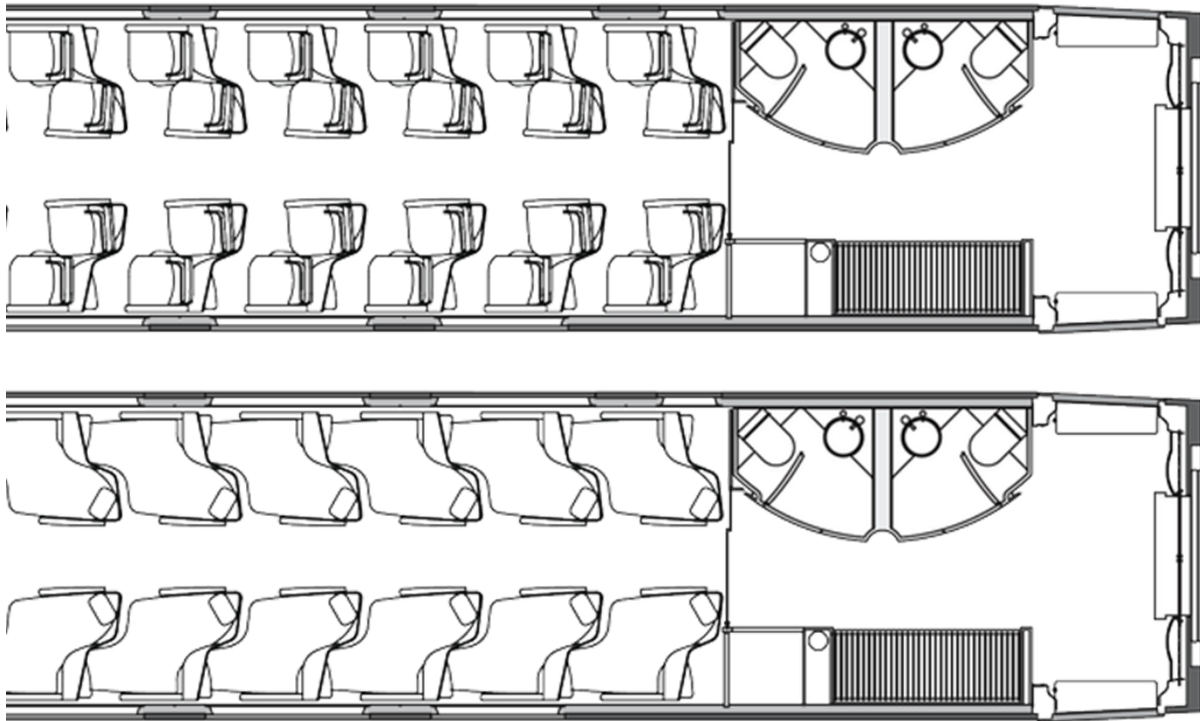

Image of Sealed Separable Passageways – Courtesy of CAF

Proposed New Coach Service Equipment for Reinvestment

For the single-level equipment used in the financial model a new seating configuration is used that can be converted between 64 seats per Reclining Coach with a divider screen or 32 Flat Pod Sleepers. The equipment is physically the same with the difference only in how it is enabled to be set up for use by the passengers. This allows for less spares to be kept for maintenance of this equipment.

If new multi-level equipment is to be used, a new 2:1 seating configuration (2 seats on one side of the aisle and 1 seat on the other side) on multiple levels by means of a duplex elevation carbody shell is proposed as the basis for a reinvestment in this service. This would allow for seats to be sold as aisle access singles at reservation time at a price if the ratio of doubles to singles is off relative to the equipment. The existing 2:2 seating configuration coaches could be rebuilt for continued use, with the seat spacing decreased slightly to become a value plus type of service offering for shorter trips.



Conceptual Reclining Coach Seat Plan with Privacy Screen Convertible to Flat-Pod – Courtesy Butterfly Rail⁷⁸

Proposed Characteristics of Rebuilt Coaches

Any type of coach would have features that enable the passenger to enjoy a higher Time-Utility, either by means of now worrying about valuables in their space, higher quality restroom fixtures similar to a hotel, or fixed seat back screens that would provide greater visual privacy and acoustical isolation between rows.

- A. Lockable valuables compartment under each seat, accessible with ticket or mobile device scan.
- B. Larger restrooms employing newer toilet technologies using clear water and self-cleaning features.
- C. Fixed seat backs, with inwardly reclining backs and cushions.

⁷⁸ Website, <<https://www.butterflyseating.com/butterfly-rail>>



Image of Proposed New Railjet/ Nighjet Coach Equipment – Courtesy of Priestman Goode

Acquisition Type	New	Incremental Cost	Per Run	Per Carmile
Railcar Capital and Rebuild	\$ (2,800,000)	Capital - RRIF Loan	\$1,454.15	
At Risk Equity Portion	10.00%	Capital - Owners Equity	\$303.78	
Interest Rate - RRIF (FRA) Loan	5.38%	Overhaul Reserves		\$0.400
Interest Rate Equivalent - At Risk Equity	13.45%	Maintenance Labor per Turn	\$140.24	
Composite Interest Rate	6.19%	Maintenance Parts per Turn		\$0.250
Financing Period Equipment (Years)	24	Cleaning Labor per Turn	\$107.88	
One-way Runs per Year -RCM Plan	143	Cleaning Consumables per Turn	\$40.00	
Spares of this type	1	On-Board Service Labor		\$0.364
Total Fleet of this type	11	Incremental Costs per Railcar	\$2,046.06	\$1.01
Consumer Selling Expense & Card Fees	2.60%	Passenger First Dollar Loss Reserves		\$0.278
Route Miles per Run (Daily Service)	2300	Collision Property Loss Reserves		\$0.150
Total Sets Assigned per Route	5.0	Switchout Costs - Setout Cars Only	\$0.00	
Maintenance Hours per Turn	2	Traction and Utility Energy		\$0.680
Cleaning Hours per Turn	2	Total Incremental Costs per Railcar	\$2,046.06	\$2.121
Route Runtime Hours	46	<u>Breakeven Revenue Analysis</u>		
Total Pre and Post Departure Hours	1.0	Units (Seats/Rooms) per Car and Occupancy	64	55%
On-Board Crew Off-duty Hours per Trip	16.0	Average Sellable Units per Car at Occupancy	34.7	
Overhaul Days per Year	7.0	Persons per Car-Mile based on One Party per Unit	34.7	
Program Overhaul Cost (LVL 2)	\$400,000	Total Incremental Costs per Railcar-Mile		\$3.01
Program Overhaul Interval Miles	1,000,000	Breakeven rate per Sellable Unit Mile		\$0.087
US Median Household Income	\$72,933			
Offroad Diesel per Gallon	\$3.40			
Cars per OBS Staff Member	2.0			
Persons per Party	1.39			
Weight-Tons	60			

Incremental Cost for Additional Single-Level Coach Car with Revised Staffing (\$3.4 with Existing Staffing Levels)

Why Overnight Rail Travel Works - Reimagining Overnight Service Objectives

There are two projects underway in Europe, even though the geography has supported higher speed rail service.⁷⁹, to significantly reinvest in new sleeper equipment. These operations are driven by the growing realization following a reduction in overnight services that the time spent shuttling from an airport to a hotel when entering a large metropolitan region can eat into a significant portion of the daylight hours as well as the reality that there are a limited number of routes where dedicated high-speed infrastructure can be efficient.

In both of these cases the operators are marketing these services as superior to what we would call regional aviation for trips under 600 miles, far beyond what US transportation planners suggest is the target for intercity passenger rail trips.

ScotRail Caledonian Sleeper Franchise

In this case a bid was put out for an operator to run the service for 15 years if they were to reinvest in new equipment with the government covering only a portion of the capital costs upfront. The operation of this route is separate from the base passenger operator over nationally held infrastructure. So the nighttime and daytime services are separate but coordinated so one can book one-way journeys on the same national reservation site. Significantly, this service also hosts long-distance commuters on both ends who desire to get to the terminal city early.



New Suite Room - Image Courtesy of [Caledonia Sleeper Franchise](#)

ÖBB Nightjet and Railjet – Overnight and Daytime Travel Service Pairing

In this case the national rail operator is pairing an overnight service (Nightjet) with their existing daytime corridor trains (Railjet) so that they can offer a more comprehensive travel service to conduct same day business. Conceptually, one could use the Nightjet service to reach an early morning appointment, then begin a return trip after lunch and arrive back later that night, all in less daytime hours than possible either driving or using connecting airline routes due to the

⁷⁹ European Parliament - Transport and Tourism. "Passenger Night Trains in Europe: The End of the Line?" 2017. <[http://www.europarl.europa.eu/RegData/etudes/STUD/2017/601977/IPOL_STU\(2017\)601977_EN.pdf](http://www.europarl.europa.eu/RegData/etudes/STUD/2017/601977/IPOL_STU(2017)601977_EN.pdf)>

need for nighttime rest. This new equipment consists of Siemens Viaggio.⁸⁰ coaches somewhat similar to the private operator of the US Brightline now Virgin Trains Florida service, ordered by ÖBB at \$2.8 M USD per car.



Image of Proposed new Nightjet Suite Room – Courtesy of ÖBB

Proposed New Sleeping Service Equipment for Reinvestment:

New room configuration allowing for all seats to face forward, with en-suite full bathrooms for all bedroom sleeper rooms, and available queen sized beds are proposed as the basis for a reinvestment in this service so as to obtain premium revenue at moderately increased average costs. These improvements would allow for a new car of this type to bring in significantly more revenue per mile, while covering all of the incremental costs to add it to the train. There is substantial evidence that this market segment is just barely being serviced by Amtrak compared to new worldwide train configurations.

A typical six person SUV has about 61square feet of floor area to the edge of the window glass, including the large windshield dash area. Just the main area of one of the larger two person sleeping compartment would be 38 square feet, not counting the restroom. Two rooms combined into a suite to hold a family of up six would equal 68 square feet, with a much higher ceiling height and with two private restrooms available to the travelers whenever they desire that are not counted in the floor area. Such an arrangement would be a superior good to regional jet trips or automobile trips over 400 miles when combined with the coordinated rental of automobiles through the various mobile platforms available today and the ability to continue traveling while sleeping. The avoided transfer of luggage to a hotel for a night should be an equal dis-utility to the transfer into a rental automobile.

⁸⁰ International Railway Journal. ÖBB agrees €1.5bn deal with Siemens for long-distance trains. 2018. <<https://www.railjournal.com/rolling-stock/bb-agrees-e145bn-deal-with-siemens-for-long-distance-trains/>>.

Sketch-level P3 Service Development Plan – Procurement, Capital, Operations, and Maintenance

It is important to note that a new economy single occupancy coach sleeper design is also needed to fully capture potential revenue from the range of trip demands. Ideally, this should be of a split-level design that does not include restroom facilities within the room. Using a split-level design (4) four completely separate, lockable, and private single rooms could be had in 88” of railcar length versus the current Amtrak Roomette of which (2) two rooms each holding (2) two people fit inside 80” of railcar length. The total revenue would benefit from being able to sell more one person parties an accommodation at a higher rate per mile, increasing the overall revenue net yield per railcar mile. This economy design is not discussed further in this paper but is an important potential leg of the total route revenue that was discarded with the introduction of the Superliner design.

Cost per Room Sleeper Railcar (\$Current US)

Acquisition Type	New	Incremental Cost	Per Run	Per Carmile
Railcar Capital and Rebuild	\$ (3,200,000)	Capital - RRIF Loan	\$1,611.52	
At Risk Equity Portion	10.00%	Capital - Owners Equity	\$336.66	
Interest Rate - RRIF (FRA) Loan	5.38%	Overhaul Reserves		\$0.500
Interest Rate Equivalent - At Risk Equity	13.45%	Maintenance Labor per Turn	\$350.61	
Composite Interest Rate	6.19%	Maintenance Parts per Mile		\$0.250
Financing Period Equipment (Years)	24	Cleaning Labor per Turn	\$161.82	
One-way Runs per Year -RCM Plan	143	Cleaning Consumables per Turn	\$90.00	
Spares of this type	1	On-Board Service Labor		\$0.364
Total Fleet of this type	16	Incremental Costs per Railcar	\$2,550.62	\$1.11
Consumer Selling Expense & Card Fees	2.60%	Passenger First Dollar Loss Reserves		\$0.103
Route Miles per Run (Daily Service)	2300	Collision Property Loss Reserves		\$0.150
Total Sets Assigned per Route	5.0	Switchout Costs - Setout Cars Only	\$0.00	
Maintenance Hours per Turn	5	Traction and Utility Energy		\$0.680
Cleaning Hours per Turn	3	Total Incremental Costs per Railcar	\$2,550.62	\$2.047
Route Runtime Hours	46	<u>Breakeven Revenue Analysis</u>		
Total Pre and Post Departure Hours	1.0	Units (Seats/Rooms) per Car and Occupancy	11.5	85%
On-Board Crew Off-duty Hours per Trip	16.0	Average Sellable Units per Car at Occupancy	9.3	
Overhaul Days per Year	7.0	Persons per Car-Mile based on One Party per Unit	12.9	
Program Overhaul Cost (LVL 2)	\$500,000	Total Incremental Costs per Railcar-Mile		\$3.16
Program Overhaul Interval Miles	1,000,000	Breakeven rate per Sellable Unit Mile		\$0.340
US Median Household Income	\$72,933			
Offroad Diesel per Gallon	\$3.40			
Cars per OBS Staff Member	2.0			
Persons per Party	1.39			

Incremental Cost for Additional Single-Level Sleeping Car with Revised Staffing (\$3.5 with Existing Staffing Levels)

Proposed Characteristics of New Sleeping Cars

The proposed design for a 12 Bedroom single level sleeper incorporates several improvements over both the old Pullman Bedrooms and the current Amtrak Bedrooms, nee Deluxe Bedrooms, to advance comfort and garner higher revenue. The design could be incorporated into a Bi-level, Superliner car-shell as well, in which case 16 Bedrooms could fit in one car.

- A. All rooms have full bathrooms, where a fold-up solid surface sink counter and wainscot hides the toilet so that the area becomes part of the main area when not in use, instead of a lost space. A zero threshold shower drain (slit drain - level with floor) allows for this dual use while improving cleaning efficiency and reducing trip hazards.
- B. The accessible room is better configured for both side transfer and sale as a general purpose room. The room design attempted to meet the changes recommended by a recent accessibility panel that are not yet codified.

- C. All couches face forward for riding comfort during the day. The 64" wide couch is less than that provided now, however for comparison this is about the shoulder level clear width inside the largest SUV on the market.
- D. Motorized jackscrews support all beds in horizontal orientations with user adjustable heights. This automates the process of nighttime conversion, allowing for the bed to be premade, with the passenger able to operate the controls when a force override is provided.
- E. Half the rooms are provided with a conventional height queen sized bed (60" x 75") closer to what one gets in a hotel. These rooms could be called Compartments and would best the revenue of anything currently offered.
- F. The larger Compartments could be paired with an adjacent standard Bedroom through a pass through door in the bathroom wall. Thus configured, families of up to two adults and four small children or three large children could travel together in two adjoining rooms. The smaller Bedroom could be configured with three beds as all frames stay horizontal and stack at the ceiling, so that four small children with Velcro attached mesh panels or parties of three young adults could be accommodated. This pair of rooms would be much larger than a stretch SUV.
- G. The attendant room is a stock Bedroom, with a tablet provided for monitoring of room attendant calls and trouble alerts, allowing call duty to be passed off to other attendants covering nighttime shifts. This would allow the attendant to occupy a room with a service defect or during periods of peak use on a segment, provide the room for misconnects when compensated by agreement. The standard bedroom would be a substantially better away from home space than provided in the current roomettes. These revised staffing plans would require a labor contract side-agreement should two of these single level cars be operated with a single attendant enabled by the labor saving and workplace improvements. Compared to a Superliner sleeper load of 42 beds on two levels the resulting 46 beds per attendant in a single level car seems within the range of a labor side-agreement.

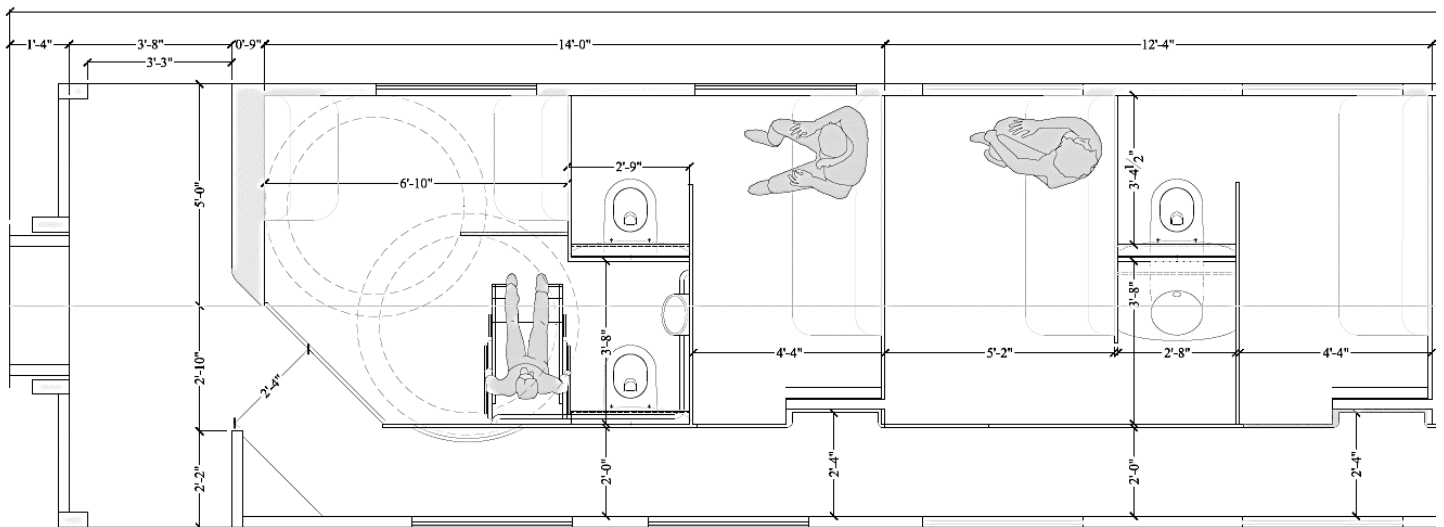

Floorplan of Proposed New Sleeping Service Equipment – Daytime Configuration - Author

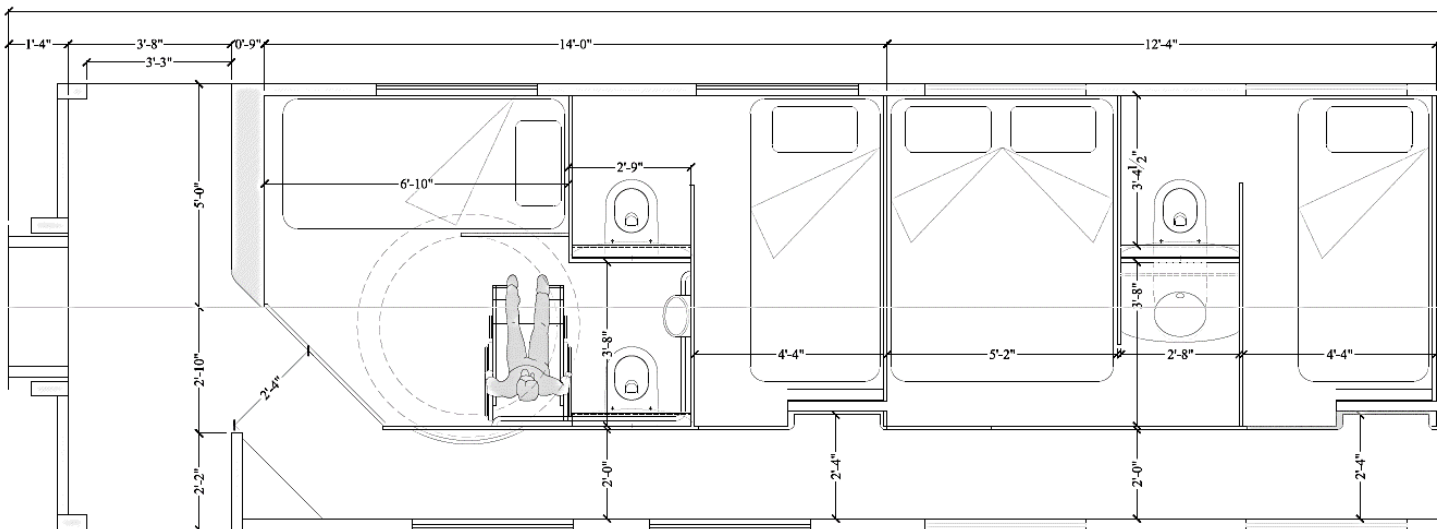

Floorplan of Proposed New Sleeping Service Equipment –Nighttime Configuration – Author

Food and Beverage – Multifunction Lounge and Diner Spaces

The Food and Beverage / Café car in the financial model is intended to be the same carbody type whether it is used as a café, lounge, or diner service with roller mounted appliances that could be exchanged in a shop. This car type would have observation windows in the seating areas which would allow with the addition of a single accessible bedroom to the car type for full access to amenities.

Conceptually, this common Café, lounge, or diner could be a short-observation dome car with the accessible sleeper room(s) on the lower level with a wheelchair lift connecting to the observation seating. Observation domes, such as the one below, were a mid-1950's innovation for single level cars, providing a unique experience for passengers that was objectively demonstrated to build passenger revenue.



North Coast Hiawatha - Lounge in the Sky – 1973, Steve Brown⁸¹

⁸¹ Riding the North Coast Limited, Flickr Album, <<https://www.flickr.com/photos/sjb4photos/sets/72157606072881534/>>

Structurally a modern dome would be no different than some modern commuter cars. The difference would be providing forward visibility and additional glazing area.

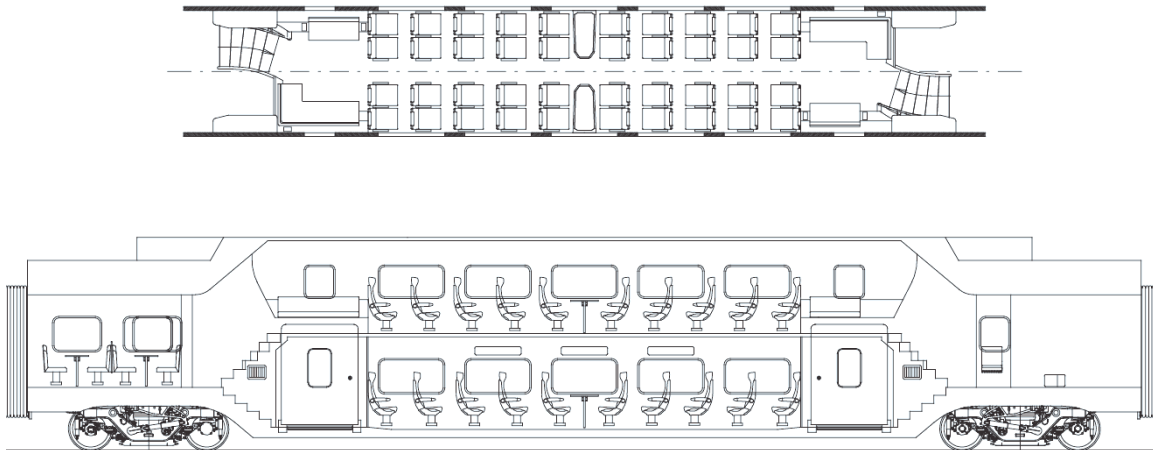

Multi-level Car - Image Courtesy of Stadler⁸²

By using the same end of car design, any structural shell that does not incorporate a center buff/draft sill would be easily modified to create a dome type single level car.



Rocky Mountaineer Modern Semi-Dome Single Level Car⁸³

⁸² <https://www.stadlerail.com/en/products/detail-all/kiss200/56/>

⁸³ A top-notch train ride: How to choose between Rocky Mountaineer's most popular routes, The Points Guy, 2023, <
<https://thepointsguy.com/guide/rocky-mountaineer-comparison/>>

Mid-Route Car Switching Improvements

The primary impediment to such a connection currently is the time it takes to add or subtract cars from the Head End Power (HEP) 480 V electrical supply and the operating plan. An industry standard near source electrical lockout could be provided at the end of each car so as to disengage the HEP electrical supply at the locomotive. This safety lockout would be able to be “Blue Flagged” using a personal lock by creating an interrupt switch in the already existing much lower power 74 Volt DC Train-line Complete circuit (TLC)⁸⁴ which must be continuous for the locomotive generator to energize the electrical power line feeding the cars.

Thus the more efficient procedure would include a beginning of shift job briefing for the through car operation for the Train and Engine personnel, establishment of protected switching limits with the dispatcher that would allow work to proceed quickly, the use of the train radio to call to the engine crew to first operate the HEP power shutdown switch on the engine before the conductor isolates and locks out the TLC circuit, then breaking and making the connections as the switching occurs rapidly. In this manner of operation, the loss of power to the occupied consist might be only 4 minutes or so, during which the emergency lights would run off battery supply.

Further, the development by the shortline rail freight industry of belt back remote operated switchers could be built upon such that a cut of cars to be moved to a connecting train route could be operated by the Conductor under dispatcher protection, using the car’s own 74 V DC battery power at a low speed of 4 mph through an electric motor urethane friction drive wheel extended onto the tread of the railroad wheel, with no switcher cost or crew call.

Express Freight Revenue and Traffic Design

Addition of Mail & Express Once Allowed Revenue to Cover Above-the-Rail Costs

The previous operating plan for Mail & Express service relied on either trans-loading pallets using forklifts from the local truck trailer into high-speed boxcars in a manual cross-dock operation or using special bi-modal truck trailers called RoadRailers that could be mated to a rail wheelset and coupled to the end of a train. These approaches were used due to the need to quickly get a service up and running that would provide net operating revenue to support the Amtrak network, but their limitations may have led to the suspension of the service in 2004, though it was reported to Congress in 1997 that a more limited service then operated generated 42%⁸⁵ of the income of the route. Should developments be made in rapid loading and flexibility to place cars at the front of the train behind the locomotives, Mail & Express haulage could have significant contributions to future revenue.

Congressional Charge to Increase Net Revenues - CFR §24306. Mail, express, and auto-ferry transportation (a) Actions To Increase Revenues. - Amtrak shall take necessary action to increase its revenues from the transportation of mail and express. To increase its revenues, Amtrak may provide auto-ferry transportation as part of the basic passenger transportation authorized by this part.

⁸⁴ APTA Commuter Rail Executive Committee. "15. APTA PR-E-RP-016-99 Recommended Practice for 480 VAC Head End Power System." 1999. <<https://www.apta.com/resources/standards/Documents/APTA-PR-E-RP-016-99.pdf>>

⁸⁵ United States Senate - 105th Congress - Subcommittee on Surface Transportation and Merchant Marine of the Committee on Commerce, Science, and Transportation. "Amtrak's Financial Situation." 1997 PG 52. <https://books.google.com/books?id=_9WPoHkU2YkC&pg=PP1&lpg=PP1&dq=senate+hearing+105-273+Amtrak%27s+financial+situation+1997>.



The *Southwest Chief* at Fullerton, CA in 2003 with Specialized Express RoadRailers – Image Copyright [Craig Walker](#)

It is important to note that the long-distance truck market has radically shifted since the 2004 decision to discontinue the service by Amtrak to simplify operations and even later 2013 studies of the overall marketplace⁸⁶ for higher speed rail intermodal freight. Notably, changes to the Hours-of-Service truck rules to ensure rested drivers and the ability to enforce such rules through electronic logging (ELD) has made a proposed express freight service using the Amtrak National Network trains to be a very clear speed winner over single driver trucking transit times. Timings just to Chicago from the Los Angeles region would be about 1 ½ days faster using the Southwest Chief train route combined with innovative, but higher initial capital cost, semi-automated transfer technologies to differentiate a new market segment at a much higher net revenue. This same advantage would be present in a Seattle to Denver or Seattle to Chicago operation.

⁸⁶ Sharma & Associates, Inc. "MARKET ANALYSIS: VALIDATION OF A 70-TON HIGHER SPEED FREIGHT TRUCK DESIGN FOR OPERATIONS UP TO 125 MPH." U.S. Department of Transportation Federal Railroad Administration, 2013.
<<https://www.transportation.northwestern.edu/documents/2015/burns-fra-report.pdf>>.

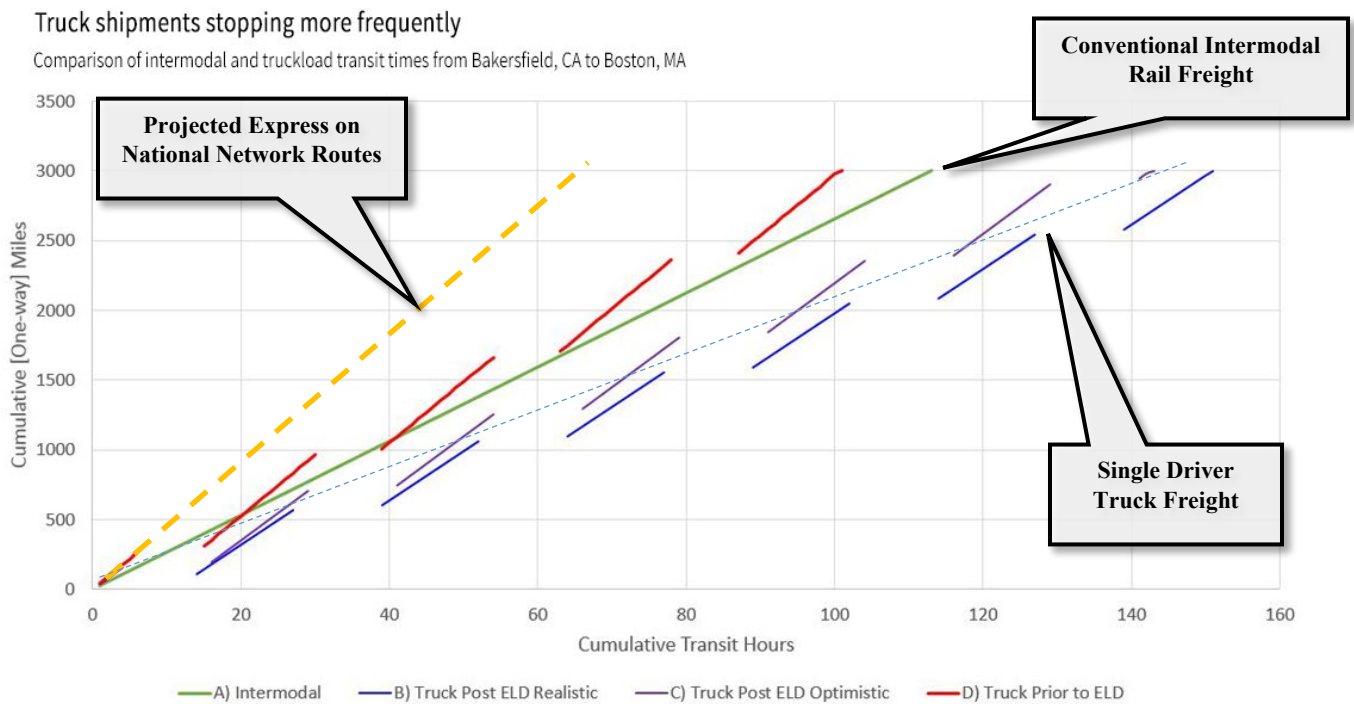

Base Chart Courtesy of Tiger Cool Express – [ELD Inflection Point⁸⁷ - Continuous Speed Lines Author’s Estimate](#)

The solutions proposed below are both highly reliant on automation so as to reduce the transfer operations staffing and operating cost through the use of kiosk type stations where either the trailer or the pallet is brought by the tractor driver or forklift operator to a kiosk after which it is inserted onto the train without additional staffing.

The transfer mechanism proposed are through much improved methods not available for the 1996-2004 operations:

- Standard Shipping Pallet Based - Automated pallet shuttle trans-loads pallets into railcars
- Standard Truck Trailer Based - Tractor drives trailer onto an automated exchange platform

The net financial returns from the standard truck trailer-based system have been modeled using costs based on the more complex UIC profile based designs and considering that the host railroads would actually sell the service as compensated agents using it as an added line of business to their existing intermodal freight menu of options while occasionally using it to restore service timings to late loads. These results are conservatively not included as they are projected to generate net revenue.

Standard Shipping Pallet Based Express Traffic

Currently warehouse automation is being achieved using various types of automated storage and retrieval systems that did not exist in common forms a decade ago. One of the more promising methods for high-value express revenue is to completely eliminate the truck trailer or container body from the rail side of transportation, breaking the smallest unit load down to the standard 40" x 48" pallet footprint.

Existing Viewliner II format baggage cars could be converted to accommodate such an automated pallet storage and retrieval system, significantly reducing the time to load a car, as a forklift on the ground platform or truck dock level roller deck could feed only to the point of the baggage car door from which the automated pallet shuttle would store

⁸⁷ Prince, Theodore. "Analysis: ELDs are US trucking’s inflection point." Journal of Commerce 26 April 2018. <<http://www.tigercoolexpress.com/analysis-elds-are-us-truckings-inflection-point/>>.

and retrieve the pallets within the confines of the car quickly. For western operations, a tri-level pallet car could be constructed in the greater overall height allowed.

Purpose built pallet express cars could bring even greater efficiency by allowing pallets to be passed between cars and loading height increased, so that a single loading point could serve several coupled cars with a much greater volume. This option would also allow for the pallets to be sorted for dispersed destinations and moved between trains at Chicago or other express route hubs in an efficient manner. The connecting hubs physically would consist of no more than short portable ramps between groups of cars on adjacent tracks with the automated pallet shuttles moving loads between cars.

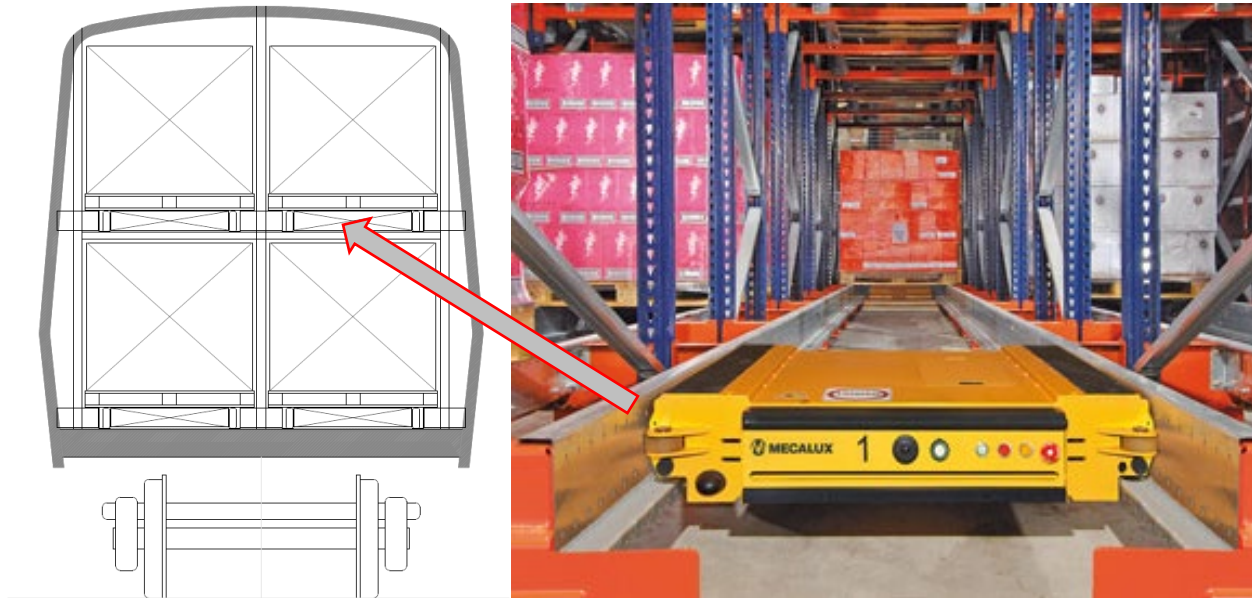

Image Courtesy of [Interlake Mecalux Automated Pallet Shuttle](#)

The automation of the functions of a Less Than Truckload (LTL) cross-dock transfer facility in such a way could allow the pricing for the service to float higher than rates for just truckload team driving, as ancillary costs of buildings would be eliminated as well as the transfer time to unload and cross-dock. Further, mid-route sorting of pallets while the train is stopped at a station would allow for handoffs of express loads at intermediate points within the timeframe of a conventional passenger train stop.

The author has further confidential designs to make the pallet shuttle concept work for in-route sorting of the pallets while the train is moving, that if ultimately applied would produce results far exceeding the net revenue estimates generated for the conventional truck trailer based express service. For this reason, further financial analysis of this option has been conservatively excluded for the route as such an operation would be on the scale that a joint venture with a private express group or e-commerce shipper would be warranted and full route cost coverage would be possible.

Standard Truck Trailer Based Express Traffic

This intermodal freight service would be priced at a level above conventional expedited trailer-based intermodal options that involve lifting the trailer onto a railcar with a crane in a slower process. However, it is proposed to be marketed by the existing agents of the host railroads as an addition to their service offering, either for valued contract customers as a service recovery option in the case of a missed train or as a expedite option. However, the ability for the trailer loading sled to take nearly any existing wheeled trailer would mean that there would be significant opportunity to attract loads

that were not advanced planned to be routed as intermodal loads due to being loaded in locally available non-compatible equipment.

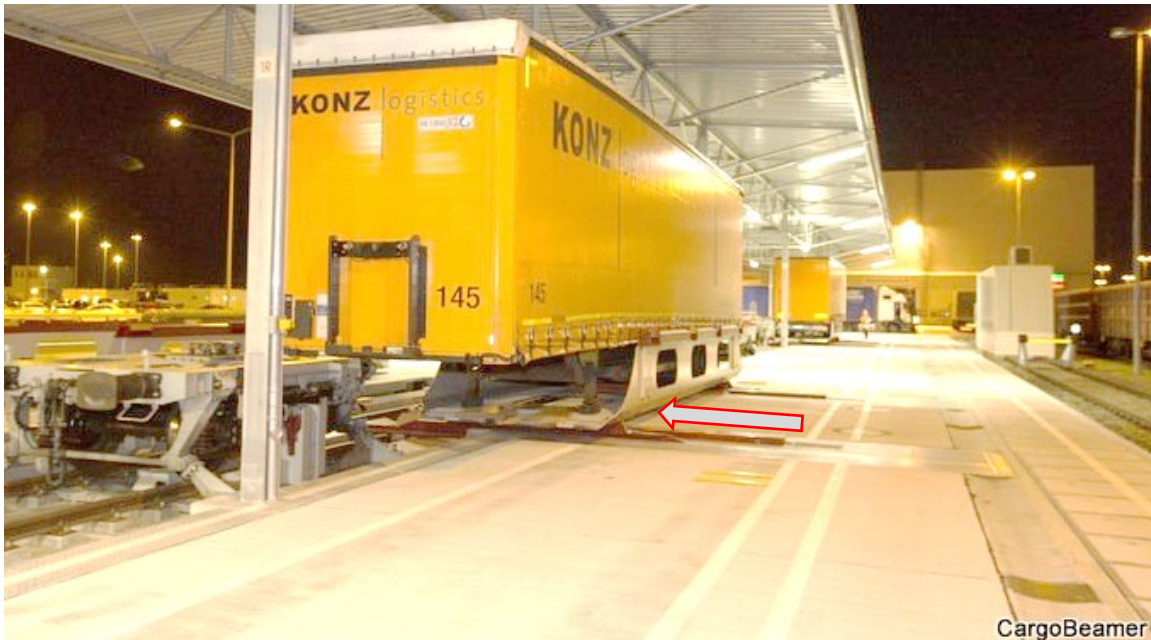

Images Courtesy of [CargoBeamer AG](#)

Transshipping 72 trailers can take as little as 15 minute using the CargoBeamer technology, at a greater capital cost, but a much reduced operational cost that also allows for the capture of very time sensitive trailer based freight traffic due to the short loading time.

The Lohr UIC wagon shown below is the most prevalent system in the EU for unmodified semi-trailers. It supports the trailers at about 9 inches above the rail and requires adjustment to keep this low profile needed to clear EU tunnels. For prevalent US loading gauges the trailer could ride around 14 inches above the rail and still clear almost all restrictive spots, which has the potential to provide a much simplified railcar and unloading concept that would accept practically any semi-trailer in use.

This ability to accept any trailer is important as often a time sensitive load will be dispatched the nearest trailer available for loading, irrespective of whether it is a domestic intermodal container on road chassis or not. The author has further confidential designs for a trailer side loader car conforming to AAR Plate B using reduced cost conventional components while still allowing for service speeds to the current 90 MPH top speeds of the route that has conservatively not been included in the financial analysis as an addition to net revenue.



Image Courtesy of [LOHR](#) and [VIA](#)

Locomotive Configurations and Fuel Types

Historically this proposed route was operated with 14-car trains with a 3—unit set of diesel-electric locomotives with a total of 4500 horsepower. Conceptually that would mean that once the Head End Power (HEP) electrical load is considered, more than one of the newer ALC-42 4200 HP engines would be required if the train has more than 9-cars.

The Above-the-Rail feedback financial loop in the P3 would provide some incentive to employ a stable, hydrogen rich RNG gas as an alternative fuel source for additional emission reduction benefits, reaching beyond Tier 5 standards for NOx and PM, and CO₂.⁸⁸ Capital costs related to Biomass produced RNG and the compressor stations needed to fill the onboard storage cylinders could be used to offset some of the startup costs and introduce the technology in a dual service way for local freight switching locomotives. The cylinders needed for this service have existing for quite some time and are approved for highway use and known to the FRA⁸⁹ as an existing technology. What typically seems to limit the application is the amount of compressed gas that can be stored onboard. Conceptually, two lower-horsepower locomotives could be supplied with say 2700 HP each and the available storage volume to take the gas cylinders onboard for full trip with a large safety margin. Combined the two would produce 5400 HP suitable for a longer train with the ability for one unit to haul the train at a lower speed to the next station.

Energy Absorbing Locomotive Nose Cone- Replaceable in the Field

With a unique design for the locomotives on the route it might make sense to incorporate an energy absorbing nose cone that could be replaced at any grade crossing with the following characteristics:

1. At 6" ATR – 0.375" steel plate horizontal diaphragm anchored back to pilot structure
2. To 16" ATR – 0.375" stainless steel snow plow – 60" of aluminum crush tubes
3. 16" ATR to lower Cab Window Sill - Thermopolyolefin (TPO) Exterior Shell
4. 24" of Expanded Polypropylene (EPP) high-impact shock absorption foam
5. 36" of aluminum crush tubes with intermediate plate every 4", progressively building stiffness

⁸⁸ <<https://optifuel.com/optifuel>>

⁸⁹<https://railroads.dot.gov/sites/fra.dot.gov/files/fra_net/18511/Liquid%20and%20Compressed%20Natural%20Gas%20and%20Locomotive%20Fuels%20brochure.pdf>

Sketch-level P3 Service Development Plan – Procurement, Capital, Operations, and Maintenance

Conceptual Above-the-Rail Route - Financial Plan

Under a future P3 Request for Quote (RFQ), the Vehicle Operator would be at Revenue Risk for all items they are responsible to provide. The P3 bidder would confirm the model at bid time using Bridging Documents from the RFQ.

Consumer Revenue Funded Passenger Train Operations (State DOT Sponsorship with Locality Station Area Commitments)						
Intermodal Passenger Vehicle Operator						
Above-the-Rail Operations	Per Train-mile	Per One-Way Run	Per Annum	Annual Total	1,679,785	Annual Train-miles
Fuel - Diesel	\$ 6.72			\$ 11,286,740	5	Passenger Trainsets for Daily Service
Train & Engine Crews (NRPC Pass Through)	\$ 8.40			\$ 14,110,192	253,017,578	Annual Auto VMT-Equivalent Miles
Running Maintenance - Common Tools & Exterior Cleaning			\$ 776,736	\$ 776,736	271,246,182	Annual Person-Miles
Passenger Amenity Consumables			\$ 1,559,643	\$ 1,559,643	452,077	Ridership
Locomotives - Capital, Maint., and Ops.	\$ 1.25	\$ 3,367		\$ 4,559,370		
Express Car - Capital, Maint., and Ops.	\$ 0.65	\$ 1,276		\$ 2,024,050		
Reclining Coaches - Capital, Maint., and Ops.	\$ 2.03	\$ 4,092		\$ 6,394,508		
Flat Pod Sleepers - Capital, Maint., and Ops.	\$ 2.03	\$ 4,192		\$ 6,467,558		
Room Sleepers - Capital, Maint., and Ops.	\$ 3.34	\$ 7,652		\$ 11,201,437		
Food and Bev. Café - Capital, Maint., and Ops.	\$ 1.48	\$ 2,630		\$ 4,402,680		
Common Area - On Board Service & Turning Crews			\$ 3,624,770	\$ 3,624,770		(5) Staff Home Bases along route - for same day turns back
Small-Loss Risk Insurance (< \$1 M) & Legal Services			\$ 2,125,000	\$ 2,125,000		
Promotions, Advertisement, and Misconnect Costs			\$ 1,400,000	\$ 1,400,000		
Route Management Offices (East, Central, and West)			\$ 1,292,778	\$ 1,292,778		
Prorated Mobilization (\$10 M)			\$ 1,250,000	\$ 1,250,000		
Intermediate Stations and Agents			\$ 985,889	\$ 985,889		
Credit Card Processing Fees and Points Program at 2.6%			\$ 2,026,810	\$ 2,026,810		
Information Technology & Mobile WiFi			\$ 525,000	\$ 525,000		
Reservation Website - Fee for Phone Assist			\$ 1,200,000	\$ 1,200,000		
Total Above-the-Rail Passenger Operations	\$ 45.97			\$ 77,213,161		Locomotive(s) 1
Consumer Revenue	Per Train-mile				Price per Mile per Party Traveling	
Express (Storage - Semi-Automated Pallet Shuttle)	\$ 2.50			\$ 4,197,782	Together	Parties
Reclining Coach (Thru-Cars)	\$ 11.10			\$ 18,652,330	\$ 0.16	69.4
Flat Pod-Sleeper (Thru-Cars)	\$ 13.35			\$ 22,425,126	\$ 0.25	53.4
Room-Sleeper (Thru-Cars)	\$ 18.23			\$ 30,614,707	\$ 0.66	27.8
Food and Beverage Café	\$ 1.23			\$ 2,064,278		
Total Consumer Revenue	\$ 46.41			\$ 77,954,224		Persons
						Cars
						9
Intermodal Passenger Vehicle Operator - Net Income				\$ 741,063	Auto VMT Equiv.	151
						161.5
						\$ 0.003

Note: This is the Minimum Operation - Thru-Cars from Portland, Auto-ferry service, and Trailer Based Intermodal Express Freight Service are Forecast as Incrementally Net Positive

Summary Financial Results for P3 Above-the-Rail Vehicle Operator – Conventional Off-Road Diesel Fuel

Consumer Revenue Funded Passenger Train Operations (State DOT Sponsorship with Locality Station Area Commitments)						
Intermodal Passenger Vehicle Operator						
Above-the-Rail Operations	Per Train-mile	Per One-Way Run	Per Annum	Annual Total	1,679,785	Annual Train-miles
Fuel - CRNG	\$ 4.33			\$ 7,275,101	5	Passenger Trainsets for Daily Service
Train & Engine Crews (NRPC Pass Through)	\$ 8.40			\$ 14,110,192	253,017,578	Annual Auto VMT-Equivalent Miles
Running Maintenance - Common Tools & Exterior Cleaning			\$ 776,736	\$ 776,736	271,246,182	Annual Person-Miles
Passenger Amenity Consumables			\$ 1,559,643	\$ 1,559,643	392,542	Ridership
Locomotives - Capital, Maint., and Ops.	\$ 1.25	\$ 3,367		\$ 4,559,370		
Express Car - Capital, Maint., and Ops.	\$ 0.65	\$ 1,276		\$ 2,024,050		
Reclining Coaches - Capital, Maint., and Ops.	\$ 2.03	\$ 4,092		\$ 6,394,508		
Flat Pod Sleepers - Capital, Maint., and Ops.	\$ 2.03	\$ 4,192		\$ 6,467,558		
Room Sleepers - Capital, Maint., and Ops.	\$ 3.34	\$ 7,652		\$ 11,201,437		
Food and Bev. Café - Capital, Maint., and Ops.	\$ 1.48	\$ 2,630		\$ 4,402,680		
Common Area - On Board Service & Turning Crews			\$ 3,624,770	\$ 3,624,770		(5) Staff Home Bases along route - for same day turns back
Small-Loss Risk Insurance (< \$1 M) & Legal Services			\$ 2,125,000	\$ 2,125,000		
Promotions, Advertisement, and Misconnect Costs			\$ 1,400,000	\$ 1,400,000		
Route Management Offices (East, Central, and West)			\$ 1,292,778	\$ 1,292,778		
Prorated Mobilization (\$10 M)			\$ 1,250,000	\$ 1,250,000		
Intermediate Stations and Agents			\$ 985,889	\$ 985,889		
Credit Card Processing Fees and Points Program at 2.6%			\$ 2,026,810	\$ 2,026,810		
Information Technology & Mobile WiFi			\$ 525,000	\$ 525,000		
Reservation Website - Fee for Phone Assist			\$ 1,200,000	\$ 1,200,000		
Total Above-the-Rail Passenger Operations	\$ 43.58			\$ 73,201,521		Locomotive(s) 1
Consumer Revenue	Per Train-mile				Price per Mile per Party Traveling	
Express (Storage - Semi-Automated Pallet Shuttle)	\$ 2.50			\$ 4,197,782	Together	Parties
Reclining Coach (Thru-Cars)	\$ 11.10			\$ 18,652,330	\$ 0.16	69.4
Flat Pod-Sleeper (Thru-Cars)	\$ 13.35			\$ 22,425,126	\$ 0.25	53.4
Room-Sleeper (Thru-Cars)	\$ 18.23			\$ 30,614,707	\$ 0.66	27.8
Food and Beverage Café	\$ 1.23			\$ 2,064,278		
Total Consumer Revenue	\$ 46.41			\$ 77,954,224		Persons
						Cars
						9
Intermodal Passenger Vehicle Operator - Net Income				\$ 4,752,702	Auto VMT Equiv.	151
						161.5
						\$ 0.018

Note: This is the Minimum Operation - Thru-Cars from Portland, Auto-ferry service, and Trailer Based Intermodal Express Freight Service are Forecast as Incrementally Net Positive

Summary Financial Results for P3 Above-the-Rail Vehicle Operator – Renewable compressed Natural Gas (RNG) Fuel

Economic Public Benefits Analysis

BCA Highway Net Incremental Capital and O&M Metric

Benefits to Rail Passengers

The values used in a conventional economic approach to benefit to cost analysis, used to rank access to a basket of financial funds, simplify several factors that are likely very important to the users of the through route. For this reason special studies have been conducted within this paper to Quantify these characteristics and evaluate them within the existing benefit to cost framework. In order to do so, example origins and destinations have been picked to calculate the savings with respect to the existing transportation alternatives as referenced literature in particular do not account for the Special Study Topics in analysis of trips from 200 miles to 1000 miles in length. It is also worth noting that the Route Financial Ratios developed include all costs above the top-of rail, above the publicly provided common use infrastructure and liability public backstop, as is consistent with highway and local road travel evaluations.

Special Study Topics:

- Time Utility Values – Utility in Mobile Work and Desired Activity for Passengers in Transit
- Trip Time of Day Inputs - Utility in Trip Arrival and Departure Times for Productivity at Destination
- Consumer Surplus Values - Reduced Marginal Automobile Operating Costs for Single Drivers

However, within the guidance for conducting a Benefit to Cost Analysis significant bias toward continuing highway investment is present as reduced automobile operating costs and time savings are noted to be excluded should drivers switch to becoming passengers, known as a mode change, while funding is present for a new highway facility that converts either passengers or shorter-trip drivers into faster speed but longer-trip drivers, drawn from an unknown pool.

“savings in costs or travel time experienced by travelers... who switch to an improved facility or service are not an accurate measure of the benefits they receive from doing so, and do not represent benefits in addition to the benefits received by additional users of the improved alternative. The generalized costs for using the competing alternatives from which an improved facility draws additional users are already incorporated in the demand curve for the improved facility or service.”⁹⁰

This sounds like a tight loop until one realizes that there is no demand curve for nationwide highway travel that extends to cost ranges that include incrementally paying for personal accident costs so as to determine the market demand volume on a segment of road. In fact most demand models use various assignment methods based on total population and ratios that are completely non-variable. So the situation is actually one of insufficient market competition, which would void a demand curve approach. For this reason, cost savings from those travelers shifting is termed consumer surplus, though logically as the volume offered by intercity rail increased to a certain point the fares could float higher to capture half of these savings as revenue. Further, to the main point of this paper, almost none of the costs of highway infrastructure are being incrementally paid for in proportion to travel due to the financial leveraging effect of a broad highway fuel tax cast over a vast network of local streets paid for by local taxes along with public funding of accident costs through non-transportation budgets.

Historically, economic benefits were counted to plan for traffic gravitating to what would be a then un-congested interstate highway to justify⁹¹ those investments. It seems quite odd to disallow for benefits to be counted for a shift from those now congested Interstate Highways when benefits from a shift to a shorter highway route are allowed.

⁹⁰ U.S. Department of Transportation. "Benefit-Cost Analysis Guidance for Discretionary Grant Programs." 2018. <https://www.transportation.gov/sites/dot.gov/files/docs/mission/office-policy/transportation-policy/284031/benefit-cost-analysis-guidance-2018_0.pdf>

⁹¹ U.S. Department of Commerce, Bureau of Public Roads. "Final report of the highway cost allocation study prepared pursuant to Section 210 of the Highway Revenue Act of 1956." 1961. <<https://catalog.hathitrust.org/Record/101679610>>

Further, since passenger rail operations are counted as a potentially severable Federal appropriations line item in each budget it would seem reasonable to argue that each new appropriation is in fact a “new” service, a take it or leave it proposition for future years. The correct view is found in broader economic benefit literature where distinctions are made between transfer payments and savings in real resources with economic value, such as keeping an automobile in service longer, avoiding a costly away from home transmission failure, or avoiding a rock cracked windshield. Certainly reductions in marginal automobile operating costs and greater time away from work due to the need to fit within sleep rhythms would qualify for inclusion by that standard as true savings of real resources.

Many of the concepts discussed as special studies are briefly touched upon as plausible factors in the guidance memo⁹² on value of time but are not developed as standard values. For this reason the studies provide particular details for each case used to establish values so that they may be reasonably reviewed.

Literature results have noted significant variabilities in Travel Time Savings on the land side of airports that can only be explained by the type of Time Utility analysis proposed. Additionally, research conducted in China where there are competing passenger services, High Speed Rail, Conventional Overnight rail, Commercial Aviation, and uncongested new Highways has found that Conventional Overnight Rail fills a 400 to 1000 mile trip length gap⁹³ between high speed rail and commercial aviation while still providing slightly less desirable coverage than high speed rail at shorter trip lengths. These results are normalized by trip length, so the larger number of shorter trips might make the overall travelers greater as highway garner a high market share of the trips less than 80 miles in in these very congested urban circumstances of China at each end of the trip.

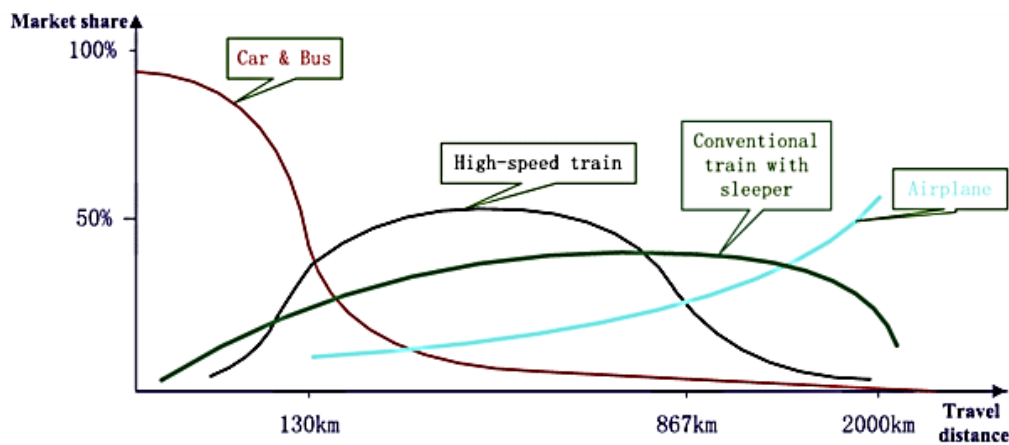

Market Share Chart - The Variation in the Value of Travel-Time Savings and the Dilemma of High-speed Rail in China

Time Utility Value Estimations

To estimate roughly the utility in having time available for mobile work or other desired activities instead of driving the conventional automobile Time Savings value of \$19.00/hour is divided by an average daytime Interstate Highway speed of 52 mph for a reference point to calculate economic savings. Then a reduced \$10.47/hour time cost, roughly estimated using a prorated seating space, foodservice, and restroom availability comfort metric developed in the following pages for railway coach travel, is divided by a 50 mph average passenger train speed to find a Utility of Time Savings of \$0.164 per passenger mile relative to the option to drive the distance in a daytime trip. This metric is applied to only 60% of the total route passenger miles for the 14.5 hours of the day during normal productive times. Due to the length of the trip

⁹² U.S. Department of Transportation "Revised Departmental Guidance on Valuation of Travel Time in Economic Analysis." 2016. <<https://www.transportation.gov/office-policy/transportation-policy/revised-departmental-guidance-valuation-travel-time-economic>>

⁹³ Jian Zhao, Yunyi Zhao, Ying Li. "The Variation in the Value of Travel-Time Savings and the Dilemma of High-speed Rail in China." Transportation Research Part A: Policy and Practice, Volume A (2015): 130-140. <<http://www.sciencedirect.com/science/article/pii/S0965856415002463>>

transfer costs are neglected in the generalized analysis as they are less than 5% of the total comparable driving trip time. The trip specific analysis does however assign values to transfer costs and other aspects of a complete trip.

Trip Time of Day Value Estimations

However, most travelers prefer to leave their destination near the late evening so a rough estimate of the Utility in Trip Arrival and Departure Times is produced by calculating absolute time savings from being able to continue moving for a trip that would otherwise require a driver to stop for the night and rest in a hotel before resuming the trip. The trip speed calculations for a 500 mile trip presented earlier, show that the actual speed for highway driving is 26 mph, inclusive of an overnight stop. So the conventional automobile Time Savings value of \$19.00/hour is multiplied by the sum of the inverse of the slower overnight highway trip speed and a faster continuous passenger train speed for a reference point to find an Absolute Time Savings of \$0.365 per passenger mile relative to the option to drive the distance in a daytime trip. This metric is applied to only 40% of the total route passenger miles for the 9.5 hours of the day during night rest periods.

Consumer Surplus Values

While this paper recommends a fare structure that is capped so that the total coach fare for a travel party does not rise above the costs to operate an automobile, there still will be some level of Consumer Surplus remaining where the ticket cost will be less than the marginal cost to operate an automobile for a single traveler. While a more complicated trip specific model should consider parking costs, the generalized value is just calculated by subtracting an average \$0.11 ticket cost in the base coach accommodation from the conventional \$0.25 per automobile mile operating cost. Single travel parties in the base coach class are estimated to be 20% of the total passenger miles, producing a generalized \$0.140 per passenger mile in consumer surplus relative to the option to drive the distance in a daytime trip that is then only applied to 1/5th of route passenger miles estimated to be from single party travelers.

Generalized versus Trip Specific Time Utility Economic Models

The generalized special study results provided above have only been calculated for the purpose of a global Benefit to Cost model run over three decades to study infrastructure investment needs as suggested modifications to the 2018 BUILD grant framework to take into account Time Utility of a traveler. The author believes that economic analysis only has a place when used in more detailed consumer calibrated models that include all of the components of a trip, such as hotel and parking costs, to estimate revenue response and pricing. These specific models should also be run for certain trip distance bands and trip start and end times. Just such an example of a detailed model is included at the end of this section to illustrate the different uses of economic models for a 4 PM departure on a 500 mile trip by two individuals.

The values are purely experimental, but the intent is to suggest that a first principles approach could be had to estimate consumer responses according to the ability of a traveler to do the things they would otherwise want to do at that time of day, such as enjoy a meal, work on a laptop, read a paper, rest, or have a restroom conveniently available nearby.

Ultimately, the Trip Specific method would combined both the Financial Price of the service and estimated Consumer Economic evaluations to try to estimate the consumer value in a way that would free the economic model to only consider consumer side estimations of trip time quality instead of mixing the economic questions up to try to justify infrastructure spending through fictitious “speed” from a large pot of money. This approach is only possible once the leverage of the default Highway Trust Fund investment is understood as discussed earlier in this paper per the examples calculations enclosed following.

Comparison of USDOT BUILD Grant Program and Time Utility Specific Trip Proposed Values

Economic Benefit Method

	Value Unit
Personal Travel Time Savings Value	\$19.00 Hour
Business Travel Time Savings Value	\$25.40 Hour
Composite Travel Time Savings Value	\$20.40 Hour
Vehicle Operating Cost	\$0.25 Vehicle Mile
Occupancy	1.39 Persons per Automobile
Safety Benefits	

Economic Time Utility / Disutility of Time

	Value Unit	Total Comfort Ratio	Restroom Access Ratio	Nighttime Level Bed	Attention Available	Personal Area
Automobile Driver Day Time Disutility	\$19.00 Hour	115.20		0.3		0.5 768
Automobile Driver Night Time Disutility	\$23.75 Hour	92.16		0.3		0.4 768
Airport/Station/Rental/Parking Time Disutility	\$27.02 Hour	81.00		0.3		0.6 450
Security Screening Time Disutility	\$32.70 Hour	60.00		0.3		0.5 400 * TRB ACRP Web Only Doc. #22 - Back checked by analysis of TSA PreCheck cost to i

	Value Unit	Total Comfort Ratio	Restroom Access Ratio	Nighttime Level Bed	Attention Available	Personal Area	Time Use Utility
Automobile Passenger Time Disutility	\$9.50 Hour	230.40		0.3		1.0	768
SUV/Crossover Passenger Time Disutility	\$7.24 Hour	302.40		0.3		1.0	1008
Taxi or Transit Time Disutility	\$13.84 Hour	158.10		0.3		1.0	527
Aircraft Passenger Coach Time Disutility	\$8.91 Hour	245.76		0.4		1.0	614 * Comfort derived by relative ratio of personal space per mode
Aircraft Passenger Business Coach Time Disutility	\$4.36 Hour	501.60		0.6		1.0	836 * Comfort derived by relative ticket price difference over trip time
Aircraft Passenger Flat Bed Night Time Disutility	\$2.18 Hour	1003.20		0.6	X	1.0	1672 * Comfort derived by relative ticket price difference over trip time
Rail Passenger Business Class Day Time Disutility	\$3.18 Hour	688.80		0.6		1.0	1148 * Comfort derived by relative ratio of personal space per mode
Rail Passenger Coach Day Time Disutility	\$5.24 Hour	418.00		0.5		1.0	836 * Comfort derived by relative ratio of personal space per mode
Rail Passenger Coach Night Time Disutility	\$5.24 Hour	418.00		0.5		1.0	836
Rail Passenger Coach Sleeper Day Time Disutility	\$4.34 Hour	504.00		0.5		1.0	1008 * Comfort derived by relative ratio of personal space per mode
Rail Passenger Coach Sleeper Night Time Disutility	\$1.37 Hour	1596.00		0.5	X	1.0	3192 * Comfort derived by relative ratio of personal space per mode
Rail Passenger Bedroom Sleeper Day Time Disutility	\$2.71 Hour	806.40		0.8		1.0	1008 * Comfort derived by relative ratio of personal space per mode
Rail Passenger Bedroom Sleeper Night Time Disutility	\$0.95 Hour	2310.40		0.8	X	1.0	2888 * Comfort derived by relative ratio of personal space per mode
Hotel Time Disutility relative to Home	\$0.55 Hour	4000.00		1.0	X	1.0	4000
Motorcoach Passenger Day Time Disutility	\$8.94 Hour	244.80		0.4		1.0	612 * Comfort derived by relative ratio of personal space per mode
Motorcoach Passenger Night Time Disutility	\$8.94 Hour	244.80		0.4		1.0	612 * Comfort derived by relative ratio of personal space per mode

Financial Trip Price

Automobile Sedan Operating Cost	\$0.25 Vehicle Mile	- Capital not included	- Capital not included
Automobile Sedan Average Cost	\$0.55 Vehicle Mile	- IRS or Rental Rate	- IRS or Rental Rate
Automobile SUV Operating Cost	\$0.30 Vehicle Mile	- Capital not included	- Capital not included
Automobile SUV Average Cost	\$0.65 Vehicle Mile	- IRS or Rental Rate	- IRS or Rental Rate
Automobile Intercity Trip Occupancy	1.39 Persons per Automobile		
Automobile Accident Cost to Users Net of Insurance			
Automobile Accident Cost to Others Net of Insurance			
Rail Coach Price	\$0.11 Passenger Mile		
Rail Business Coach Price	\$0.20 Passenger Mile		
Rail Coach Sleeper Price	\$0.28 Passenger Mile	- One Person Capacity	- One Person Capacity
Rail Bedroom Sleeper Price	\$0.60 Room Mile	- Two Persons Capacity with En	- Two Persons Capacity with Ensuite Restroom
Motorcoach Price	\$0.09 Passenger Mile		
Hotel Metro Area 3 Star	\$140 Each Night	- Two Persons Capacity	- Two Persons Capacity
Gym Club/Day Hotel Room	\$20 Each Morning		
Parking Metro	\$28 Each Day		
Parking Airport	\$28 Each Day		
Baggage Airline Fee	\$30 Each		
Long Taxi Trip	\$40 Each		
Short Taxi Trip	\$20 Each		

Trip Specific Time-Utility Model - Combined Economic and Financial Trip Preference Estimation

Trip Start Time 4:00 PM
 Trip Length (Ground Measure) 500 Miles
 Persons per Party 2 Person(s)

Economic Time Disutility Costs	<u>Airline</u>		<u>Highway</u>		<u>Highway</u>		<u>Railway</u>		<u>Railway</u>		<u>Railway</u>		<u>Highway</u>	
	Hours	Disutility Cost	Hours	Disutility Cost	Hours	Disutility Cost	Hours	Disutility Cost	Hours	Disutility Cost	Hours	Disutility Cost	Hours	Disutility Cost
Automobile Driver Day Time Disutility	0.5	\$9.50	7	\$133.00	7	\$133.00	0.5	\$9.50	0.5	\$9.50	0.5	\$9.50	0.5	\$9.50
Automobile Driver Night Time Disutility		\$0.00	2	\$47.50	2	\$47.50		\$0.00		\$0.00		\$0.00		\$0.00
Automobile Passenger Time Disutility	0.5	\$4.75	9	\$85.50		\$0.00	0.5	\$4.75	0.5	\$4.75	0.5	\$4.75	0.5	\$4.75
SUV/Crossover Passenger Time Disutility		\$0.00		\$0.00	9	\$65.14		\$0.00		\$0.00		\$0.00		\$0.00
Security Screening Time Disutility	0.3	\$19.62		\$0.00		\$0.00		\$0.00		\$0.00		\$0.00		\$0.00
Aircraft Passenger Coach Time Disutility	1.9	\$34.04		\$0.00		\$0.00		\$0.00		\$0.00		\$0.00		\$0.00
Hotel Time Disutility relative to Home	10.5	\$11.49	10.5	\$11.49	10.5	\$11.49		\$0.00		\$0.00		\$0.00		\$0.00
Taxi or Transit Time Disutility	1.2	\$33.23		\$0.00		\$0.00		\$0.00		\$0.00		\$0.00		\$0.00
Rail Passenger Coach Day Time Disutility		\$0.00		\$0.00		\$0.00	3	\$31.42		\$0.00		\$0.00		\$0.00
Rail Passenger Coach Night Time Disutility		\$0.00		\$0.00		\$0.00	8	\$83.78		\$0.00		\$0.00		\$0.00
Rail Passenger Bedroom Sleeper Day Time Disutility		\$0.00		\$0.00		\$0.00		\$0.00	0.5	\$2.71		\$0.00		\$0.00
Rail Passenger Bedroom Sleeper Night Time Disutility		\$0.00		\$0.00		\$0.00		\$0.00	10.5	\$19.89		\$0.00		\$0.00
Rail Passenger Coach Sleeper Day Time Disutility		\$0.00		\$0.00		\$0.00		\$0.00		\$0.00	0.5	\$4.34		\$0.00
Rail Passenger Coach Sleeper Night Time Disutility		\$0.00		\$0.00		\$0.00		\$0.00		\$0.00	10.5	\$28.80		\$0.00
Motorcoach Passenger Day Time Disutility		\$0.00		\$0.00		\$0.00		\$0.00		\$0.00		\$0.00	6	\$107.29
Motorcoach Passenger Night Time Disutility		\$0.00		\$0.00		\$0.00		\$0.00		\$0.00		\$0.00	8	\$143.06
Total Economic Disutility of Time Value		\$112.63		\$277.49		\$257.13		\$129.45		\$36.86		\$47.39		\$264.60

Financial Travel Price	<u>Airline</u>		<u>Highway</u>		<u>Highway</u>		<u>Railway</u>		<u>Railway</u>		<u>Railway</u>		<u>Highway</u>	
	Unit Rate	Price	Rate	Price	Rate	Price	Rate	Price	Rate	Price	Rate	Price	Rate	Price
Automobile Sedan Operating Cost	\$0.25	\$7.50	\$0.25	\$125.00			\$0.25	\$7.50	\$0.25	\$7.50	\$0.25	\$7.50	\$0.25	\$7.50
Automobile SUV Operating Cost					\$0.30	\$150.00								
Airfare Base per Airmile at 85% of Ground Miles	\$0.52	\$524.72												
Rail Coach Price							\$0.11	\$110.00						
Rail Business Coach Price														
Rail Bedroom Sleeper Price									\$0.60	\$300.00				
Rail Coach Sleeper Price											\$0.28	\$280.00		
Motorcoach Price													\$0.09	\$90.00
Hotel Metro Area 3 Star	1	\$140.00	1	\$140.00	1	\$140.00								
Gym Club/Day Hotel Room							1	\$20.00					1	\$20.00
Parking Metro			1	\$28.00	1	\$28.00	1	\$28.00	1	\$28.00	1	\$28.00	1	\$28.00
Parking Airport	1	\$28.00												
Baggage Airline Fee	1	\$30.00												
Long Taxi Trip	1	\$40.00												
Short Taxi Trip							1	\$20.00	1	\$20.00	1	\$20.00	1	\$20.00
Total Financial Trip and Accommodation Price		\$770.22		\$293.00		\$318.00		\$185.50		\$355.50		\$335.50		\$165.50
Total Perceived Trip Cost (Economic and Financial)		\$882.85		\$570.49		\$575.13		\$314.95		\$392.36		\$382.89		\$430.10

Trip Specific Time-Utility Model - Combined Economic and Financial Trip Preference Estimation

Trip Start Time 4:00 PM
 Trip Length (Ground Measure) 700 Miles
 Persons per Party 2 Person(s)

Economic Time Disutility Costs	<u>Airline</u>		<u>Highway</u>		<u>Highway</u>		<u>Railway</u>		<u>Railway</u>		<u>Railway</u>		<u>Highway</u>	
	Hours	Disutility Cost	Hours	Disutility Cost	Hours	Disutility Cost	Hours	Disutility Cost	Hours	Disutility Cost	Hours	Disutility Cost	Hours	Disutility Cost
Automobile Driver Day Time Disutility	0.5	\$9.50	11.5	\$218.50	11.5	\$218.50	0.5	\$9.50	0.5	\$9.50	0.5	\$9.50	0.5	\$9.50
Automobile Driver Night Time Disutility		\$0.00	2	\$47.50	2	\$47.50		\$0.00		\$0.00		\$0.00		\$0.00
Automobile Passenger Time Disutility	0.5	\$4.75	13.5	\$128.25		\$0.00	0.5	\$4.75	0.5	\$4.75	0.5	\$4.75	0.5	\$4.75
SUV/Crossover Passenger Time Disutility		\$0.00		\$0.00	13.5	\$97.71		\$0.00		\$0.00		\$0.00		\$0.00
Security Screening Time Disutility	0.3	\$19.62		\$0.00		\$0.00		\$0.00		\$0.00		\$0.00		\$0.00
Aircraft Passenger Coach Time Disutility	2.4	\$41.96		\$0.00		\$0.00		\$0.00		\$0.00		\$0.00		\$0.00
Hotel Time Disutility relative to Home	10.5	\$11.49	10.5	\$11.49	10.5	\$11.49		\$0.00		\$0.00		\$0.00		\$0.00
Taxi or Transit Time Disutility	1.2	\$33.23		\$0.00		\$0.00		\$0.00		\$0.00		\$0.00		\$0.00
Rail Passenger Coach Day Time Disutility		\$0.00		\$0.00		\$0.00	5	\$52.36		\$0.00		\$0.00		\$0.00
Rail Passenger Coach Night Time Disutility		\$0.00		\$0.00		\$0.00	10.5	\$109.96		\$0.00		\$0.00		\$0.00
Rail Passenger Bedroom Sleeper Day Time Disutility		\$0.00		\$0.00		\$0.00		\$0.00	5	\$27.14		\$0.00		\$0.00
Rail Passenger Bedroom Sleeper Night Time Disutility		\$0.00		\$0.00		\$0.00		\$0.00	10.5	\$19.89		\$0.00		\$0.00
Rail Passenger Coach Sleeper Day Time Disutility		\$0.00		\$0.00		\$0.00		\$0.00		\$0.00	5	\$43.43		\$0.00
Rail Passenger Coach Sleeper Night Time Disutility		\$0.00		\$0.00		\$0.00		\$0.00		\$0.00	10.5	\$28.80		\$0.00
Motorcoach Passenger Day Time Disutility		\$0.00		\$0.00		\$0.00		\$0.00		\$0.00		\$0.00	9	\$160.94
Motorcoach Passenger Night Time Disutility		\$0.00		\$0.00		\$0.00		\$0.00		\$0.00		\$0.00	10.5	\$187.76
Total Economic Disutility of Time Value		\$120.55		\$405.74		\$375.21		\$176.58		\$61.29		\$86.48		\$362.96

Financial Travel Price	<u>Airline</u>		<u>Highway</u>		<u>Highway</u>		<u>Railway</u>		<u>Railway</u>		<u>Railway</u>		<u>Highway</u>	
	Unit Rate	Price	Rate	Price	Rate	Price	Rate	Price	Rate	Price	Rate	Price	Rate	Price
Automobile Sedan Operating Cost	\$0.25	\$7.50	\$0.25	\$175.00			\$0.25	\$7.50	\$0.25	\$7.50	\$0.25	\$7.50	\$0.25	\$7.50
Automobile SUV Operating Cost					\$0.30	\$210.00								
Airfare Base per Airmile at 85% of Ground Miles	\$0.40	\$559.74												
Rail Coach Price							\$0.11	\$154.00						
Rail Business Coach Price														
Rail Bedroom Sleeper Price									\$0.60	\$420.00				
Rail Coach Sleeper Price											\$0.28	\$392.00		
Motorcoach Price													\$0.09	\$126.00
Hotel Metro Area 3 Star	1	\$140.00	1	\$140.00	1	\$140.00								
Gym Club/Day Hotel Room							1	\$20.00					1	\$20.00
Parking Metro			1	\$28.00	1	\$28.00	1	\$28.00	1	\$28.00	1	\$28.00	1	\$28.00
Parking Airport	1	\$28.00												
Baggage Airline Fee	1	\$30.00												
Long Taxi Trip	1	\$40.00												
Short Taxi Trip							1	\$20.00	1	\$20.00	1	\$20.00	1	\$20.00
Total Financial Trip and Accommodation Price		\$805.24		\$343.00		\$378.00		\$229.50		\$475.50		\$447.50		\$201.50
Total Perceived Trip Cost (Economic and Financial)		\$925.79		\$748.74		\$753.21		\$406.08		\$536.79		\$533.98		\$564.46

Transport Emissions Reductions

Passenger Transportation

The emissions savings modeled in the Economic BCA section as benefits are those from the use of conventional diesel locomotives. Given the intent to operate this route with a closed loop of specially designed equipment it would be the ideal route to employ Renewable Natural Gas (RNG) or conventional Compressed Natural Gas (CNG) locomotive fuels to allow for complete emissions offsets with biomass produced RNG as the technology matures while achieving cost savings relative to liquid fuel sources.

Importantly, in the event of another liquid fuels crisis as seen in the 1970's or just a sustained price hike these fuel gases will likely remain reasonably priced which would allow the service to expand the volume offered in each trainset. The specifics of the benefits of these fuels have not been modeled but the full SDP should consider them and offer specifications to the bidders.

Freight Transportation

Intermodal freight transportation is around three times as fuel efficient as trucks using Interstate Highways. The Economic BCA section as benefits are those from the use of conventional diesel locomotives. While not included there are additional possibilities to convert those existing diesel locomotives to RNG or CNG with a tender. The specifics of the benefits of these fuels have not been modeled but the full SDP should consider them and offer specifications to the bidders.

Benefit to Cost Analysis Summary

Typical Passenger Rail only BCA Results (\$2018) NPV of 30 Years of Operation at 4% Discount Rate		BCA Accounting for Highway Net Incremental Capital and O&M (\$2018) With Increased P3 Capacity for Freight and Passenger Mobility	
	North Coast Limited/Hiawatha		North Coast Limited/Hiawatha
Corridor Length (Miles)	2250	Corridor Length (Miles)	2250
NPV Benefits		NPV Benefits	
Roads and Highways		Roads and Highways	
Oil Import Savings	\$30,810,758	Oil Import Savings	\$217,039,351
Reduction in Pavement Damages	\$3,442,155	Reduction in Auto Highway Net Incremental Capital and O&M	\$292,060,720
CO2 Emissions Savings	\$82,956,842	Reduction in Truck Highway Net Incremental Capital and O&M	\$623,830,637
Non CO2 Emissions Savings	\$15,584,236	Auto CO2 Emissions Savings	\$90,505,847
Road Fatality Reductions	\$192,327,494	Auto Non CO2 Emissions Savings	\$17,002,389
Road Injury Reductions	\$92,057,749	Truck CO2 Emissions Savings	\$576,175,462
Vehicle Property Damage Reductions	\$14,114,081	Truck Non CO2 Emissions Savings	\$108,240,071
Mode Shift Benefits		Mode Shift Benefits	
Daytime Productivity Increases from Transfers to Rail	\$338,593,894	Daytime Productivity Increases from Transfers to Rail	\$369,405,664
Nighttime Speed Increases from Transfers to Rail	\$384,404,110	Nighttime Speed Increases from Transfers to Rail	\$419,384,572
Induced Passenger Benefits		Induced Passenger Benefits	
Induced Passenger Benefits	\$21,408,152	Induced Passenger Benefits	\$23,356,277
NPV Total Benefits	\$1,175,699,472	NPV Total Benefits	\$3,344,833,982
NPV Costs		NPV Costs	
Infrastructure Costs	\$698,022,000	Infrastructure Costs	\$698,022,000
Passenger Rail - Rolling Stock Capital	\$240,000,000	Passenger Rail - Rolling Stock Capital	\$320,000,000
Passenger Rail - O&M Costs	\$432,808,696	Passenger Rail - O&M Costs	\$497,687,373
Passenger Rail - Revenue (Rail Fare Transfer)	-\$519,121,800	Passenger Rail - Revenue (Rail Fare Transfer)	-\$825,535,230
Passenger Rail - Terminal, Risk, and Mainline Access Costs	\$166,989,000	Passenger Rail - Terminal, Risk, and Mainline Access Costs	\$185,969,433
Passenger Rail - Terminal Depreciation and Legacy Costs (Est.)	\$120,000,000	Passenger Rail - Terminal Depreciation and Legacy Costs (Est.)	\$120,000,000
Residual Value (offset) Remaining Infrastructure Life	-\$139,604,400	Freight Rail - Rolling Stock and O&M Costs (Net of Tarrif)	\$0
Contingency Costs (10% of infrastructure and rolling stock)	\$93,802,200	Residual Value (offset) Remaining Infrastructure Life	-\$139,604,400
NPV Total Cost	\$1,092,895,696	Contingency Reserve (10% of Rolling Stock)	\$32,000,000
NPV Costs subtracted from Benefits	\$82,803,776	NPV Total Costs	\$888,539,176
		NPV Costs subtracted from Benefits	\$2,456,294,805

Benefit to Cost Analysis Ratio (BCA) = 1.08

Benefit to Cost Analysis Ratio (BCA) = 3.76

Next Steps in the FRA led Amtrak Long-Distance Service Study

The three key elements identified need to be considered in the next phase of the FRA Amtrak Daily Long-Distance Study for it to produce the full range of policy guidance that Congress requested. The use of parametric values could allow this work to occur in just a few months.

1. **Highway Net Incremental Capital and O&M** – Establishment of a nationwide basis for correcting the market price-demand curves in Benefit to Cost Analysis calculations for highway fund financial leveraging resulting from HTF funds that never pass through a BCA grant gate.
2. **P3 Financial and Performance Metrics** – Enacting grant guidance for distributing funding by enhanced Intermodal Freight and Passenger train-mile operated atop existing fixed commuter district funding.
3. **Time-Utility Ridership Model** – Encouraging ridership modelers to explore real-world factors like the quality of the user’s experience instead of disproven time-saved wage rate analysis.

Developing these concepts beyond the sketch-level SDP to the point where bids could be taken is needed as Congress considers legislation to illustrate how funding metrics can support truly resource efficient industrial development and community resiliency benefits across the interior of the United States. The criteria for selecting long-distance passenger routes are consumer revenue covering Above-the-Rail cost under state sponsorship if the federal government pays for the Below-the-Rail infrastructure and risk, simple.

Perhaps enough experience has been gained for these changes to make it into legislation as the price of doing the same thing is getting too high⁹⁴ when a competitive P3 could bring benefits in an accelerated timeframe by moving from a series decade-plus approval process to a parallel implementation program of a few years.

Appendix

1. NRPC, Brightline, and Long Commuter Route - Above-the-Rail and Below-the-Rail Financial Analysis
2. Sketch-Level SDP *Mainstreet* and *North Coast Limited* Route
3. Conceptual Modern Room Sleeping Car with Improved Consumer Appeal

⁹⁴ Wilner, Frank N. A failure of public enterprise? Railway Age. [Online] November 2018. <<https://www.railwayage.com/passenger/intercity/a-failure-of-public-enterprise/>>.

Table B-2. Fully Allocated Costs by Subfamily, Pre-Audit FY2018 Dollars (Millions)
This table provides the allocated costs of each APT Subfamily.

APT Average Costs FY2018 Dollars (Millions) -
Responsibility for Infrastructure and Operations parsed per
Highway and Aviation Divisions

Family	Family Name	Subfamily Number	Subfamily Name	Operating Costs (Millions)	Percent of Amtrak Fully Allocated Costs	Operating and Capital Costs (Millions)	% of Operating and Capital
FM_MOW	Maintenance of Way	FM_101	Central Div MoW	\$19.90	0.5%	\$26.30	0.5%
		FM_102	MidAtlantic Div MoW	\$93.20	2.2%	\$150.30	2.7%
		FM_103	New England Div MoW	\$59.10	1.4%	\$85.30	1.5%
		FM_104	New York Div MoW	\$110.10	2.6%	\$140.10	2.5%
		FM_105	MoW Support	\$113.80	2.7%	\$572.60	10.4%
		FM_106	System Gangs	\$8.60	0.2%	\$114.00	2.1%
		FM_107	West Div MoW	\$11.10	0.3%	\$11.20	0.2%
		FM_108	Empire District	\$10.70	0.3%	\$14.70	0.3%
		FM_109	Michigan Line	\$10.30	0.2%	\$10.40	0.2%
FM_MOE	Maintenance of Equipment	FM_201	MoE Turnaround	\$163.00	3.9%	\$163.30	3.0%
		FM_202	MoE Loco Maintenance	\$88.30	2.1%	\$88.50	1.6%
		FM_203	MoE Car Maintenance	\$38.00	0.9%	\$38.00	0.7%
		FM_204	MoE Support	\$39.10	0.9%	\$44.00	0.8%
		FM_205	MoE Multiple	\$186.60	4.4%	\$344.00	6.2%
		FM_206	MoE HSR Maintenance	\$57.60	1.4%	\$58.20	1.1%
		FM_207	MoE Back Shop	\$18.00	0.4%	\$79.10	1.4%
		FM_208	MoE Material Control	\$10.60	0.3%	\$10.60	0.2%
FM_OPS_TRANS	Ops - Transportation	FM_301	On Board Services (OBS)	\$262.70	6.2%	\$262.70	4.8%
		FM_302	T&E	\$438.40	10.4%	\$438.40	7.9%
		FM_303	Yard	\$71.00	1.7%	\$71.20	1.3%
		FM_304	Fuel	\$128.10	3.0%	\$128.10	2.3%
		FM_305	Transportation - Multiple	\$11.50	0.3%	\$11.50	0.2%
FM_OPS_TRANS	Ops - Transportation	FM_306	Train Movement	\$86.70	2.0%	\$86.80	1.6%
		FM_307	Train Movement - Host RR	\$152.30	3.6%	\$160.10	2.9%
		FM_308	Transportation Support	\$77.60	1.8%	\$149.80	2.7%
		FM_309	Power - Electric Traction	\$81.10	1.9%	\$81.10	1.5%
		FM_310	Stations	\$196.90	4.7%	\$196.90	3.6%
FM_SALES_MKTG	Sales and Marketing	FM_401	Sales	\$10.30	0.2%	\$10.30	0.2%
		FM_402	Information & Reservations	\$73.00	1.7%	\$73.00	1.3%
		FM_403	Marketing	\$54.90	1.3%	\$77.40	1.4%
		FM_404	Station and On- Board Technology	\$5.00	0.1%	\$5.00	0.1%
FM_G_A	General and Administrative	FM_601	Corporate Administration	\$144.10	3.4%	\$190.30	3.4%
		FM_602	Centralized Services	\$237.20	5.6%	\$296.40	5.4%
		FM_603	Qualified Mgmt	\$971.50	23.0%	\$1,015.60	18.4%
		FM_604	Direct Customer (Non-NTS)	\$49.40	1.2%	\$154.10	2.8%
		FM_605	Subsidiary	\$39.20	0.9%	\$39.20	0.7%
FM_UTILITIES	Utilities	FM_801	Utilities	\$5.80	0.1%	\$5.80	0.1%
FM_POLICE_SAFETY	Police, Environmental & Safety	FM_901	Police	\$58.90	1.4%	\$60.90	1.1%
		FM_902	Emergency Mgmt & Corp Security	\$28.40	0.7%	\$34.40	0.6%
		FM_903	Environmental & Safety	\$7.40	0.2%	\$22.30	0.4%
Grand Total				\$4,229.10	100%	\$5,521.60	100%

Below-the-Rail Infrastructure Investment (Mostly Fixed with Respect to Train Movements)	Above-the-Rail Operations (Mostly Variable with Respect to Train Movements)
X \$26.30	
X \$150.30	
X \$85.30	
X \$140.10	
X \$572.60	
X \$114.00	
X \$11.20	
X \$14.70	
X \$10.40	
	X \$163.30
	X \$88.50
	X \$38.00
	X \$44.00
	X \$344.00
	X \$58.20
	X \$79.10
	X \$10.60
	X \$262.70
	X \$438.40
X \$71.20	
	X \$128.10
	X \$11.50
X \$86.80	
X \$160.10	
X \$149.80	
	X \$81.10
X \$196.90	
	X \$10.30
	X \$73.00
	X \$77.40
	X \$5.00
	X \$190.30
	X \$296.40
	X \$1,015.60
	X \$154.10
X \$39.20	
X \$5.80	
X \$60.90	
	X \$34.40
X \$22.30	
\$1,917.90	\$3,604.00

Reconciliation of APT Formula to Actual FY2018 Costs and Revenues

FY2018 Federal Government Investment after FRA withholding ¹		\$1,924.90	
Below-the-Rail Infrastructure Remaining to be Covered by Operations		(\$7.00)	\$7.00
Actual FY2018 Total Operating, Capital, Interest, Pensions, Tax, and Net Change in Cash ¹	\$5,063.70		
APT Formulaic Cost Above Actual FY2018 Costs	\$457.90	9.0%	\$ (457.90)
Total Above-the-Rail Operations Cost + Remaining Infrastructure Cost			\$ 3,153.10
Actual FY2018 Total Revenues (Tickets, State Contributions, Ancillary, and Other Core) ¹			\$ 3,386.70

1. Consolidated Financial Statements National Railroad Passenger Corporation and Subsidiaries (Amtrak) for FY2018

Table B-2. Fully Allocated Costs by Subfamily, Pre-Audit FY2019 Dollars (Millions)

This table provides the allocated costs of each APT Subfamily.

APT Average Costs FY2019 Dollars (Millions) - Responsibility for Infrastructure and Operations parsed per Highway and Aviation Divisions

Family	Family Name	Subfamily Number	Subfamily Name	Operating Costs (Millions)	Percent of Amtrak Fully Allocated Costs	Operating and Capital Costs (Millions)	% of Operating and Capital
FM_MOW	Maintenance of Way	FM_101	Central Div MoW	\$19.00	0.4%	\$24.60	0.4%
		FM_102	MidAtlantic Div MoW	\$92.10	2.1%	\$156.10	2.7%
		FM_103	New England Div MoW	\$67.30	1.5%	\$93.70	1.6%
		FM_104	New York Div MoW	\$112.30	2.6%	\$156.80	2.7%
		FM_105	MoW Support	\$117.20	2.7%	\$573.60	9.9%
		FM_106	System Gangs	\$5.60	0.1%	\$116.30	2.0%
		FM_107	West Div MoW	\$9.00	0.2%	\$9.20	0.2%
		FM_108	Empire District	\$9.90	0.2%	\$13.80	0.2%
		FM_109	Michigan Line	\$16.10	0.4%	\$16.20	0.3%
FM_MOE	Maintenance of Equipment	FM_201	MoE Turnaround	\$228.80	5.2%	\$229.10	4.0%
		FM_202	MoE Loco Maintenance	\$90.30	2.1%	\$89.80	1.5%
		FM_203	MoE Car Maintenance	\$45.80	1.0%	\$46.00	0.8%
		FM_204	MoE Support	\$43.60	1.0%	\$47.90	0.8%
		FM_205	MoE Multiple	\$142.30	3.2%	\$367.20	6.3%
		FM_206	MoE HSR Maintenance	\$58.90	1.3%	\$59.40	1.0%
		FM_207	MoE Back Shop	\$21.70	0.5%	\$79.60	1.4%
		FM_208	MoE Material Control	\$11.30	0.3%	\$11.30	0.2%
FM_OPS_TRANS	Ops - Transportation	FM_301	On Board Services (OBS)	\$277.70	6.3%	\$277.70	4.8%
		FM_302	T&E	\$463.00	10.5%	\$463.20	8.0%
		FM_303	Yard	\$74.60	1.7%	\$74.90	1.3%
		FM_304	Fuel	\$120.30	2.7%	\$120.30	2.1%
		FM_305	Transportation - Multiple	\$4.00	0.1%	\$4.00	0.1%
FM_OPS_TRANS	Ops - Transportation	FM_306	Train	\$91.10	2.1%	\$91.20	1.6%
		FM_307	Train Movement - Host RR	\$150.50	3.4%	\$175.60	3.0%
		FM_308	Transportation Support	\$75.90	1.7%	\$132.40	2.3%
		FM_309	Power - Electric	\$80.80	1.8%	\$80.80	1.4%
		FM_310	Stations	\$241.70	5.5%	\$241.80	4.2%
FM_SALES_MKTG	Sales and Marketing	FM_401	Sales	\$12.60	0.3%	\$12.60	0.2%
		FM_402	Information & Reservations	\$70.50	1.6%	\$70.50	1.2%
		FM_403	Marketing	\$61.40	1.4%	\$77.20	1.3%
		FM_404 ⁷	Station and On-Board Technology	\$0.00	0.0%	\$0.00	0.0%
		FM_405	Service Line Mgmt.	\$35.20	0.8%	\$89.30	1.5%
FM_G_A	General and Administrative	FM_601	Corporate Administration	\$68.20	1.6%	\$75.70	1.3%
		FM_602	Centralized Services	\$265.90	6.1%	\$408.60	7.0%
		FM_603	Qualified Mgmt	\$19.70	0.4%	\$64.40	1.1%
		FM_604	Direct Customer	\$24.70	0.6%	\$24.70	0.4%
		FM_605	Claims Mgmt	\$25.50	0.6%	\$25.50	0.4%
		FM_801	Centralized Expense	\$1,046.70	23.8%	\$1,089.90	18.8%
FM_POLICE_SAFETY	Police, Environmental & Safety	FM_901	Police	\$58.80	1.3%	\$60.40	1.0%
		FM_902	Emergency Mgmt & Corp Security	\$21.70	0.5%	\$25.50	0.4%
		FM_903	Environmental & Safety	\$8.90	0.2%	\$24.00	0.4%
Grand Total				\$4,229.10	100%	\$5,521.60	100%

Below-the-Rail Infrastructure Investment (Mostly Fixed with Respect to Train Movements)	Above-the-Rail Operations (Mostly Variable with Respect to Train Movements)
X \$24.60	
X \$156.10	
X \$93.70	
X \$156.80	
X \$573.60	
X \$116.30	
X \$9.20	
X \$13.80	
X \$16.20	
	X \$229.10
	X \$89.80
	X \$46.00
	X \$47.90
	X \$367.20
	X \$59.40
	X \$79.60
	X \$11.30
	X \$277.70
	X \$463.20
X \$74.90	
	X \$120.30
	X \$4.00
X \$91.20	
X \$175.60	
X \$132.40	
	X \$80.80
X \$241.80	
	X \$12.60
	X \$70.50
	X \$77.20
	X \$0.00
	X \$89.30
	X \$75.70
	X \$408.60
	X \$64.40
	X \$24.70
	X \$25.50
	X \$1,089.90
X \$60.40	
	X \$25.50
X \$24.00	
\$1,986.10	\$3,814.70

Reconciliation of APT Formula to Actual FY2019 Costs and Revenues

Above-the-Rail and Below-the-Rail Financial Analysis

	Parametric	Benchmark
AAF/Brightline SEC Filing (Made Parametric) Likely Higher than Actual		
Miami to Orlando One-way Route (Miles)	235	235
Average Schedule Speed (MPH)	74.4	74.4
Utilization Miles per Hour - Full Schedule Cycle	58.9	58.9
Est. Cycles per Day per each Equipment Set	1.5	1.5
Trip Time (Hours)	3.16	3.16
Departure Terminal Dwell (Hours)	1.08	1.08
Turning Terminal Dwell (Hours)	0.58	0.58
Total Round Trip Cycle Time	8.0	8.0
Average Trainset Miles per Day at Given Cycles per Day	706	706
Train-Miles (Millions)	2.747	2.747
Train-Hours	23,329	23,329
Seats per Train-Mile	572	348
Seat-Miles (Millions)	1,571.101	955.845
Car-Miles (Millions)	32.960	19.227
Equipment Sets	10	10
Annual Train-miles per Set (Millions)	0.275	0.275
Locomotives per Set	2	2
First Class Coaches per Set	4	2
Seats per Car	50	50
Business Class Coaches per Set	6	4
Seats per Car	62	62
Café Cars per Set	2	1
Total Car per Set	12	7
Stated Total Operating Labor		\$45.9
<u>Corporate, Station, and Parking Garage Operating Expense</u>		
Est. Station and Parking Garage Operating Labor Portion	\$14.0	\$14.0
Est. Corporate Operating Labor Portion	\$10.6	\$10.6
Marketing & Advertising	\$2.2	\$2.2
Station Expense	\$3.6	\$3.6
Information Technology	\$7.9	\$7.9
Parking Garage	\$5.6	\$5.6
Other G & A	\$2.8	\$2.8
Total	\$46.7	\$46.7
<u>Above-the-Rail Operating and Maintenance Expense</u>		
Est. Rail Operations Labor	\$27.8	\$21.3
Maintenance of Equipment	\$16.4	\$11.3
Fuel	\$22.3	\$16.4
Maintenance Facility	\$3.5	\$3.5
Est. Equipment Development & Testing	\$172.5	
Est. Equipment Cost Variable wrt Pieces	\$525.0	
Est. Total Equipment Cost	\$697.5	\$549.0
Est. Bond Equiv. Interest	6.50%	6.50%
Depreciation Length (Years)	30	30
Est. Equipment Lease Annual Payment/ Depreciation	\$54.2	\$42.7
Est. VMA - Heavy Maintenance and Parts Contract	\$24.0	\$14.0
Total	\$148.3	\$109.2

<u>Sales and Consumables Expense</u>		
Credit Card Fees (Revised to be 2.6% of Above-the-Rail & Consumables)	\$5.7	\$4.5
Passenger Meal Costs (Est. 30% Variable)	\$17.9	\$12.0
Complimentary Meal Costs (Est. 30% Variable)	\$7.6	\$5.1
Total	\$31.3	\$21.6
<u>Below-the-Rail Infrastructure Maintenance & Risk Expense</u>		
Maintenance of Way	\$18.5	\$18.5
Insurance (Risk of Infrastructure Use)	\$7.7	\$7.7
Total	\$26.2	\$26.2
<u>Below-the-Rail Infrastructure Capital Depreciation</u>		
Est. Bond Equiv. Interest	4.00%	4.00%
Depreciation Length (Years)	50	50
Railway Track and Signal	\$2,567.0	\$2,567.0
Railway Track and Signal Depreciation (Annually)	\$119.5	\$119.5
Land Lease - Right of Way	\$8.3	\$8.3
Total	\$127.8	\$127.8
<u>Above-the-Rail Train Operations and Common Expense Analysis (Long-run Average Cost)</u>		
Above-the-Rail - Train Operating and Equipment Expense (Train-mile)	\$53.99	\$39.75
per Average Car-Mile	\$4.50	\$5.68
per Incremental Car-Mile	\$2.85	
per Average Seat-Mile	\$0.094	\$0.114
Above-the-Rail - Sales and Consumables Expense (Train-mile)	\$11.38	\$7.86
Common - Parking, Station Ops., and Corporate Expense (Train-mile)	\$17.00	\$17.00
only Est. Parking Garage Costs per (Train-mile)	\$3.31	\$3.31
Total Operating, Sales, Consumables, and Common (Train-mile)	\$82.37	\$64.61
per Average Car-Mile	\$6.86	\$9.23
per Incremental Car-Mile	\$3.55	
per Average Seat-mile	\$0.144	\$0.186
per Person-Mile at 60% Occupancy incl. Parking	\$0.240	\$0.309
<u>Below-the-Rail Infrastructure Investment Analysis (Long-run Average Cost)</u>		
Below-the-Rail Infrastructure Maintenance (Train-mile)	\$9.54	\$9.54
Below-the-Rail Infrastructure Capital Depreciation (Train-mile)	\$46.53	\$46.53
per Person-mile at 60% Occupancy	\$0.163	\$0.269
<u>Combined All Transportation Business Analysis (Long-run Average Cost)</u>		
Required Total Revenue per Average Person-mile at 60% Occupancy	\$0.403	\$0.578
Projected - All Business Total Annual Cost Including Infrastructure	\$380.25	\$331.47
Projected - All Business Total Annual Revenue	\$656.75	\$399.56
<u>Analysis with Public Investment for Below-the-Rail Infrastructure Equivalent to Highway Revenue Gap</u>		
<u>Proposed Below-the-Rail Tax Credits for Infrastructure Investment Equivalent to Highway Revenue Gap</u>		
Proposed Federal Tax Credit per Passenger Train-Mile	\$17.20	\$17.20
Proposed Federal Tax Credit per Intermodal Freight Train-Mile	\$21.00	\$21.00
<u>Remaining Below-the-rail Infrastructure to be covered by Direct Consumer Revenue after Tax Credit</u>		
Remaining Below-the-Rail Infrastructure Investment (Train-mile)	\$17.87	\$17.87
per Person-mile at 60% Occupancy	\$0.052	\$0.086
Required Total Revenue per Average Person-mile at 60% Occupancy	\$0.292	\$0.395

FY2017 National Transportation Database Analysis of Commuter Rail Operations by Train-Mile

Name	City	State	NTD ID	Organization Type	Primary UZA			TOS	Vehicle Operations	Vehicle Maintenance	Facility Maintenance	General Administration	Total	Vehicle Revenue		Passenger Cars per Train-Mile	Vehicle Operations and Maintenance per Train-Mile	Vehicle Operations and Maintenance per Car-Mile
					Population	Mode	CR							Hours	Train-Miles			
Central Puget Sound Regional Transit Authority	Seattle	WA	00040	Independent Pu	3,059,393	CR	PT	\$15,520,339	\$11,460,893	\$10,048,568	\$8,472,362	\$45,502,162	63,935	340,503	5.8	\$79.24	\$13.65	
Massachusetts Bay Transportation Authority	Boston	MA	10003	Independent Pu	4,181,019	CR	PT	\$257,361,456	\$114,094,542	\$4,307,122	\$23,277,345	\$399,040,465	799,152	4,841,871	5.3	\$76.72	\$14.48	
Connecticut Department of Transportation	Newington	CT	10102	State Governme	924,859	CR	PT	\$12,834,471	\$8,439,686	\$4,241,839	\$4,630,331	\$30,146,327	38,230	608,171	3.5	\$34.98	\$10.07	
Northern New England Passenger Rail Authority	Portland	ME	10115	Independent Pu	203,914	CR	PT	\$9,988,116	\$7,825,358	\$1,937,119	\$2,045,771	\$21,796,364	69,698	451,371	4.9	\$39.47	\$8.12	
Metro-North Commuter Railroad Company, dba: MTA	New York	NY	20078	Subsidiary Unit	18,351,295	CR	DO	\$408,076,528	\$281,229,165	\$317,272,869	\$213,654,739	\$1,220,233,301	2,099,132	10,722,397	7.2	\$64.29	\$8.97	
New Jersey Transit Corporation	Newark	NJ	20080	Other Publicly-C	18,351,295	CR	DO	\$459,325,398	\$228,355,827	\$140,118,603	\$143,475,789	\$971,275,617	1,881,455	9,602,851	6.8	\$71.61	\$10.57	
MTA Long Island Rail Road	Jamaica	NY	20100	Subsidiary Unit	18,351,295	CR	DO	\$481,179,011	\$438,547,959	\$261,361,580	\$180,863,778	\$1,361,952,328	2,125,167	8,644,444	8.8	\$106.40	\$12.13	
Southeastern Pennsylvania Transportation Authority	Philadelphia	PA	30019	Independent Pu	5,441,567	CR	DO	\$147,837,067	\$40,873,107	\$52,296,779	\$28,639,262	\$269,646,215	917,500	5,273,736	3.9	\$35.78	\$9.20	
Maryland Transit Administration	Baltimore	MD	30034	State Governme	2,203,663	CR	PT	\$78,621,564	\$28,466,291	\$6,183,081	\$29,320,829	\$142,591,765	169,957	1,297,422	5.3	\$82.54	\$15.46	
Pennsylvania Department of Transportation	Harrisburg	PA	30057	State Governme	5,441,567	CR	PT	\$13,869,116	\$14,444,601	\$3,621,417	\$19,309,427	\$51,244,561	74,436	844,474	5.0	\$33.53	\$6.71	
Virginia Railway Express	Alexandria	VA	30073	Independent Pu	4,586,770	CR	PT	\$36,099,622	\$10,803,769	\$5,122,457	\$21,953,812	\$73,979,660	74,767	404,459	6.5	\$115.97	\$17.79	
Delaware Transit Corporation	Dover	DE	30075	Independent Pu	5,441,567	CR	PT	\$0	\$0	\$0	\$65,250	\$65,250	0	404,459	6.5	\$0.00	\$0.00	
South Florida Regional Transportation Authority	Pompano Bea	FL	40077	Independent Pu	5,502,379	CR	PT	\$31,930,913	\$19,335,445	\$24,982,353	\$14,677,076	\$90,925,787	121,880	1,167,777	3.1	\$43.90	\$14.13	
Regional Transportation Authority	Nashville	TN	40159	Independent Pu	969,587	CR	PT	\$921,388	\$1,346,561	\$459,198	\$1,525,513	\$4,252,660	7,890	89,434	2.6	\$25.36	\$9.92	
Central Florida Commuter Rail	Sanford	FL	40232	State Governme	1,510,516	CR	PT	\$6,798,760	\$8,865,562	\$12,033,975	\$6,410,086	\$34,108,383	25,678	308,267	2.2	\$50.81	\$23.04	
Metro Transit	Minneapolis	MN	50027	Subsidiary Unit	2,650,890	CR	PT	\$4,751,704	\$3,015,993	\$1,992,879	\$5,501,224	\$15,261,800	14,482	148,780	3.8	\$52.21	\$13.66	
Northern Indiana Commuter Transportation District	Chesterton	IN	50104	Independent Pu	8,608,208	CR	DO	\$21,898,294	\$13,039,580	\$3,745,889	\$9,774,508	\$48,458,271	115,659	795,717	5.7	\$43.91	\$7.76	
Northeast Illinois Regional Commuter Railroad Corpora	Chicago	IL	50118	Independent Pu	8,608,208	CR	DO	\$310,063,192	\$171,032,990	\$141,792,010	\$119,832,130	\$742,720,322	1,437,803	7,201,311	6.4	\$66.81	\$10.52	
Fort Worth Transportation Authority	Fort Worth	TX	60007	Independent Pu	5,121,892	CR	PT	\$322,785	\$5,513	\$335,275	\$1,525,816	\$2,189,389	0	0	6.4	\$0.00	\$0.00	
Dallas Area Rapid Transit	Dallas	TX	60056	Independent Pu	5,121,892	CR	PT	\$10,816,263	\$4,518,374	\$7,183,110	\$5,749,751	\$28,267,498	72,469	585,899	2.8	\$26.17	\$9.19	
Rio Metro Regional Transit District	Albuquerque	NM	60111	Independent Pu	741,318	CR	PT	\$8,850,436	\$5,990,425	\$7,136,469	\$6,453,532	\$28,430,862	35,706	485,839	2.9	\$30.55	\$10.68	
Utah Transit Authority	Salt Lake City	UT	80001	Independent Pu	1,021,243	CR	DO	\$12,042,361	\$6,841,622	\$5,348,535	\$10,206,211	\$34,438,729	154,744	1,343,424	4.0	\$14.06	\$3.51	
Denver Regional Transportation District	Denver	CO	80006	Independent Pu	2,374,203	CR	PT	\$26,379,241	\$5,856,777	\$3,070,656	\$3,929,438	\$39,236,112	71,128	1,327,258	2.0	\$24.29	\$12.14	
North County Transit District	Oceanside	CA	90030	Independent Pu	2,956,746	CR	PT	\$4,816,130	\$4,276,976	\$2,976,825	\$5,980,021	\$18,049,952	34,422	287,990	5.0	\$31.57	\$6.30	
Peninsula Corridor Joint Powers Board dba: Caltrain	San Carlos	CA	90134	Independent Pu	3,281,212	CR	PT	\$43,818,371	\$23,147,609	\$15,730,174	\$44,613,645	\$127,309,799	217,327	1,390,674	5.4	\$48.15	\$8.94	
Southern California Regional Rail Authority dba: Metro	Los Angeles	CA	90151	Independent Pu	12,150,996	CR	PT	\$76,243,620	\$38,562,545	\$36,726,147	\$70,487,364	\$222,019,676	359,520	2,816,066	4.8	\$40.77	\$8.55	
Altamont Corridor Express	Stockton	CA	90182	Independent Pu	370,583	CR	PT	\$6,713,804	\$3,045,413	\$3,754,736	\$8,070,154	\$21,584,107	28,013	183,300	6.2	\$53.24	\$8.52	

\$2,487,079,950	\$1,493,422,583	\$1,073,779,665	\$990,445,164
Costs:			
Total Vehicle Operations and Maintenance		\$3,980,502,533	
Total Facilities and Administration		\$2,064,224,829	
Revenues and Investments:		Percent of Total	
Passenger Fares		\$3,200,533,321	53%
Proposed Federal Investment (\$17.2/TM)		\$953,070,999	16%
Proposed Remaining Local Sponsor Share		\$1,891,123,042	31%

Note: In some cases Vehicle Operations includes Infrastructure Access

Train-Miles	61,567,894	Average	\$64.65
Diesel Powered Long-Route (Low Three Average)			\$21.86

Estimated routes over 50 miles are 90% of Train-miles

Sketch-Level SDP Mainstreeter and North Coast Limited Route

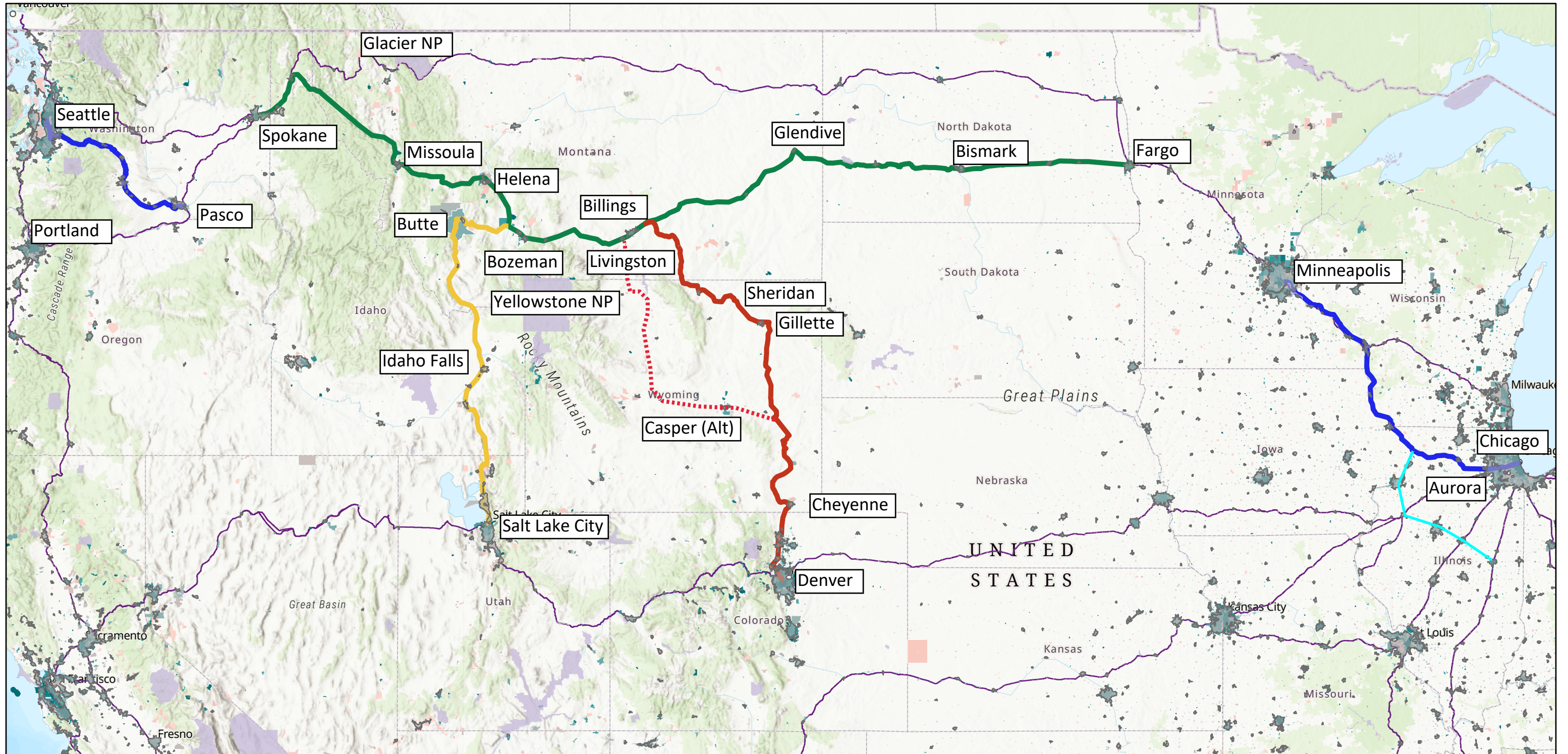

9/28/2023

1:10,000,000

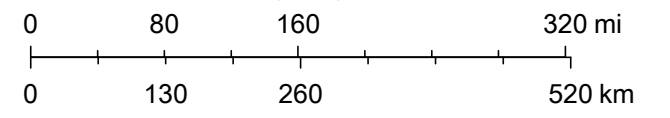
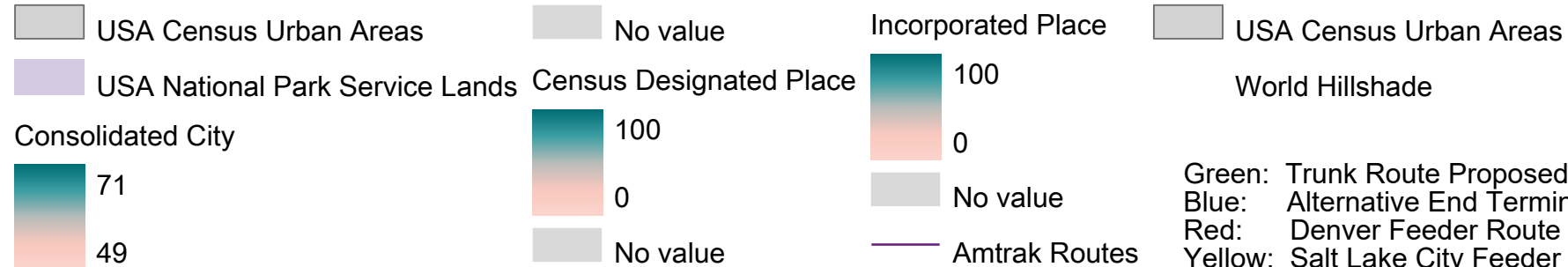

Esri, HERE, Garmin, FAO, NOAA, USGS, EPA, Esri, USGS

Green: Trunk Route Proposed Minimum Segment to Meet Some Objectives
 Blue: Alternative End Terminal Feeder Route
 Red: Denver Feeder Route
 Yellow: Salt Lake City Feeder Route
 Cyan: Major Motorcoach End Feeder Route

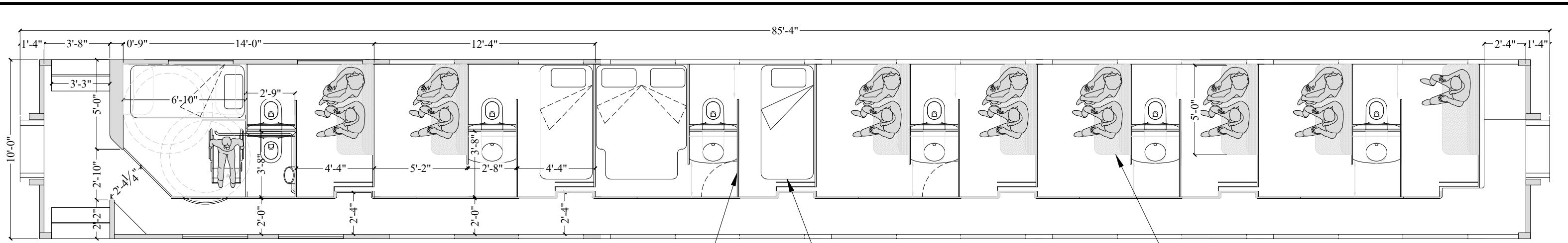

DOOR IN WALL FOR CONVERTIBLE BEDROOM SUITE

STACKED TWIN SIZED BERTHS RAISE TO CEILING

ALL BENCHES FACE FORWARD

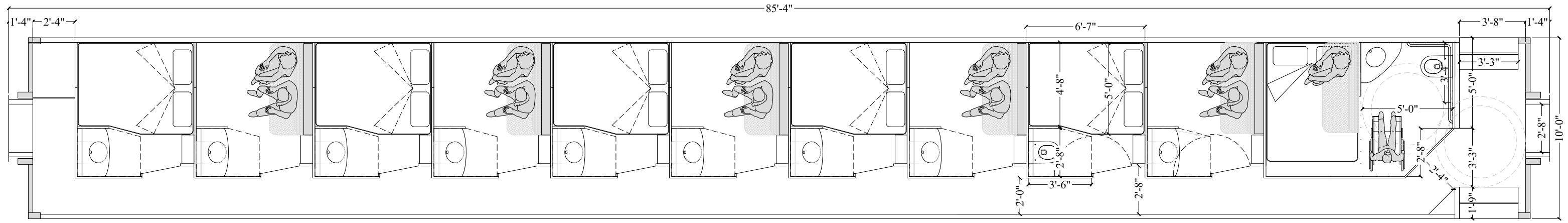

QUEEN SIZED BED, CAN FOLD FROM WALL OR DROP FROM CEILING

OUTLINE OF HINGED FULL SINK-VANITY COUNTER THAT WHEN DOWN COVERS TOILET WITH WAINSCOT BELOW COUNTER EDGE

OUTLINE OF ZERO-THRESHOLD SHOWER DRAIN, OPERABLE PARTITION ENCLOSES BATHROOM AREA

CLOSET

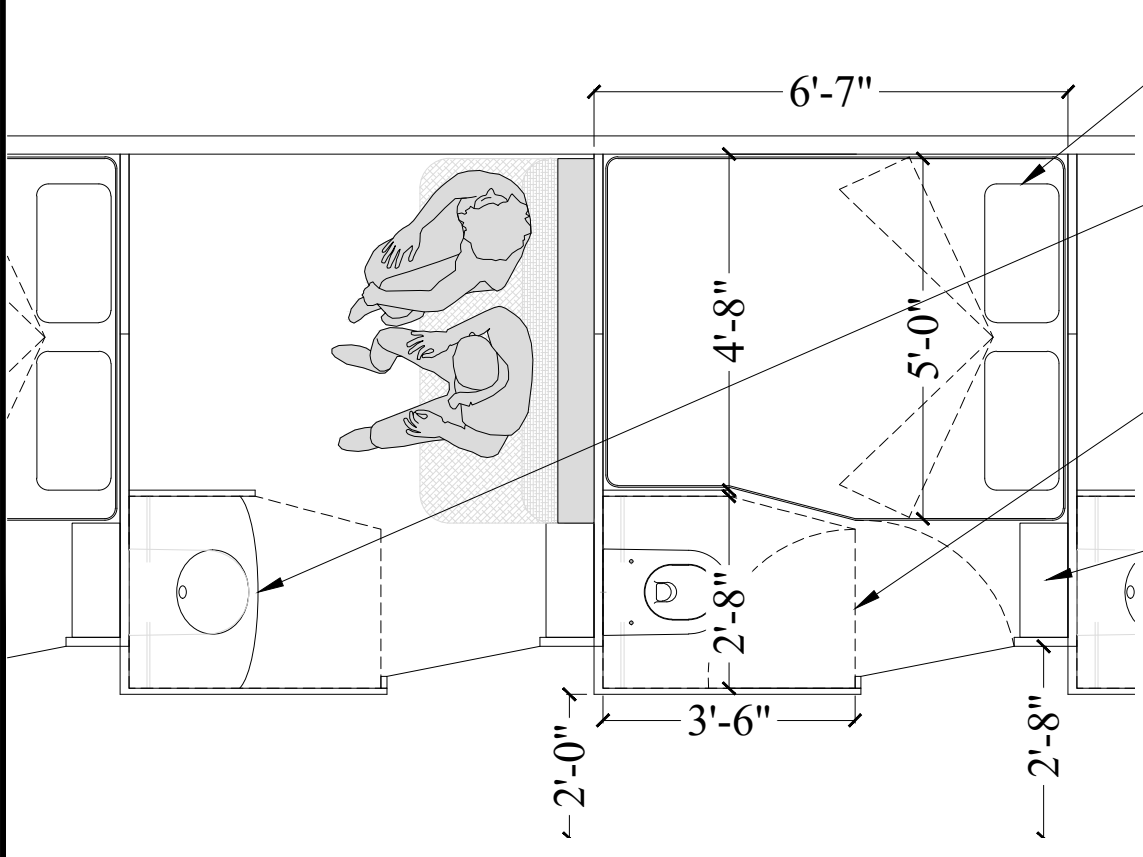

Drawn By: VGP	Date: 2021.09.28	Drawing Name: ALTERNATE CONCEPTS TO FIT BEDROOM SUITES INTO REPURPOSED CARSHELLS
Checked By: --	Date: --	
Revision: 0	Date: --	
P3 Vehicle Operator		Drawing Scale: AS SHOWN

MODERN SLEEPING CAR	
ALTERNATE CONCEPTS TO FIT BEDROOM SUITES INTO REPURPOSED CARSHELLS	
Drawing Scale: AS SHOWN	Sheet: 1 of 1