



FISCAL YEAR 2024

CAPITAL BUDGET PROPOSAL

Fiscal Years 2024-2035 Capital Program







CONTENTS

Letter from SEPTA Leadership	5
Capital Program Overview	5
SEPTA Forward	10
Project Metro	11
Bus Revolution	20
Reimagining Regional Rail	26
Capital Funding	32
Capital Program Descriptions	41
Appendices	122



A Letter From Leadership

We are a region built on transit.

SEPTA operates one of the oldest rail fleets in the country – our trolleys were built 40 years ago and most of our Regional Rail fleet is almost 50 years old. While we work to replace these fleets, we’re also modernizing stations that were built a century ago, well before accessibility standards were in place. Today, this historic transportation system remains more than essential: it’s what enables people in Greater Philadelphia to lead productive, enjoyable, meaningful lives. Hundreds of thousands of people rely on SEPTA to reach jobs, schools, and essential services; cultural centers, recreation, houses of worship, and life-changing opportunities every day. That’s why we are prioritizing essential infrastructure work and safety and security improvements to maximize the reliability and effectiveness of our aging system.

Our transformational investments in Trolley Modernization and accessibility projects on the Broad Street Line and Market-Frankford Line means that **99% of SEPTA Metro trips will be through an accessible station by 2035**, compared to 61% today. Over the last year, SEPTA has made significant progress on delivering on these promises. We awarded a contract for new trolleys, broke ground on station accessibility projects, and received additional funding to accelerate projects.

Even with this critical progress, SEPTA must do more to address a \$5.1 billion state of good repair backlog as assets are aging faster than they can be replaced. While peer regions have invested an average of 75% more in transit than southeastern Pennsylvania and the federal Bipartisan Infrastructure Law presents a historic opportunity, our region runs the risk of missing out on this generational opportunity. Without new options for matching funds, the southeast region and Pennsylvania will miss out on an additional \$2 billion in federal infrastructure investment over the next decade—putting our region’s future at risk.



Pasquale T. Deon
SEPTA Board Chairman



Leslie S. Richards
SEPTA Chief Executive Officer/GM

Approved and Projected Capital Funding (in Millions)

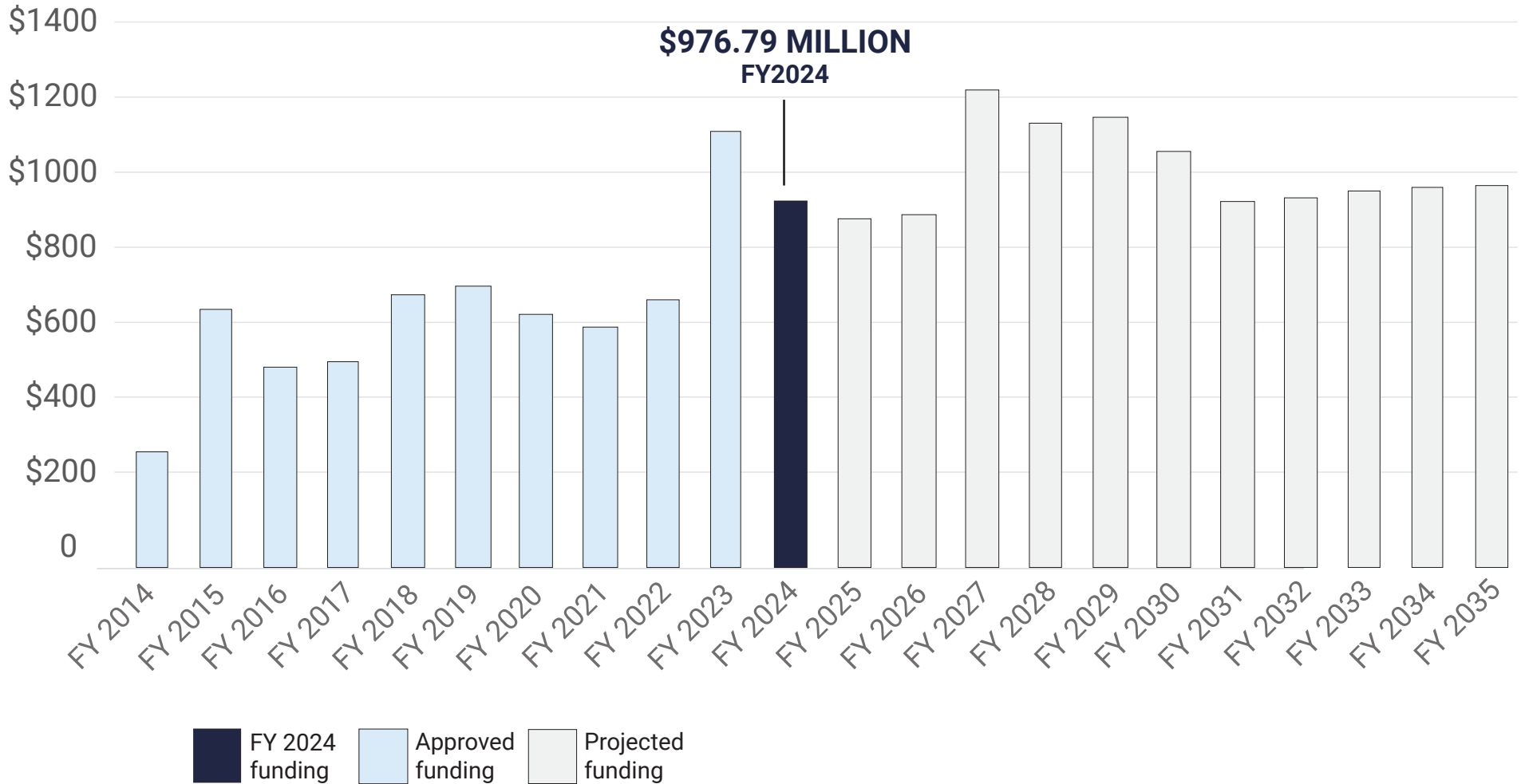

PROVIDING BENEFITS ACROSS THE REGION

The Southeastern Pennsylvania region is built on the strength of our diverse communities and neighborhoods. SEPTA connects people to what makes the region unique. It links the workers, offices, educational institutions, and other resources that makes our region so attractive to businesses.

But SEPTA is more than the sum of our parts—we support equity and enhance quality of life by catalyzing the economy, connecting people with opportunity, sustaining our environment, and supporting safe and healthy lifestyles.

\$4 billion
annual statewide
economic activity

and has catalyzed additional growth and development across Southeastern PA.

\$33 billion
in housing value
in southeastern PA

Access to transit represented 8% of total housing value, highlighting the enduring value of living near transit.

\$15.8 billion
or 38% of total
tax revenues

to the state general fund. Transit makes this possible.



• TRANSIT IS AN ECONOMIC ENGINE

SEPTA contributes directly to our region's economy and spurs broader economic growth. **Southeastern Pennsylvania, which covers 5% of Pennsylvania's land area, accounts for 41% of the Commonwealth's total economic activity.** This degree of economic productivity and density is **only possible with transit to efficiently connect people throughout the region.**

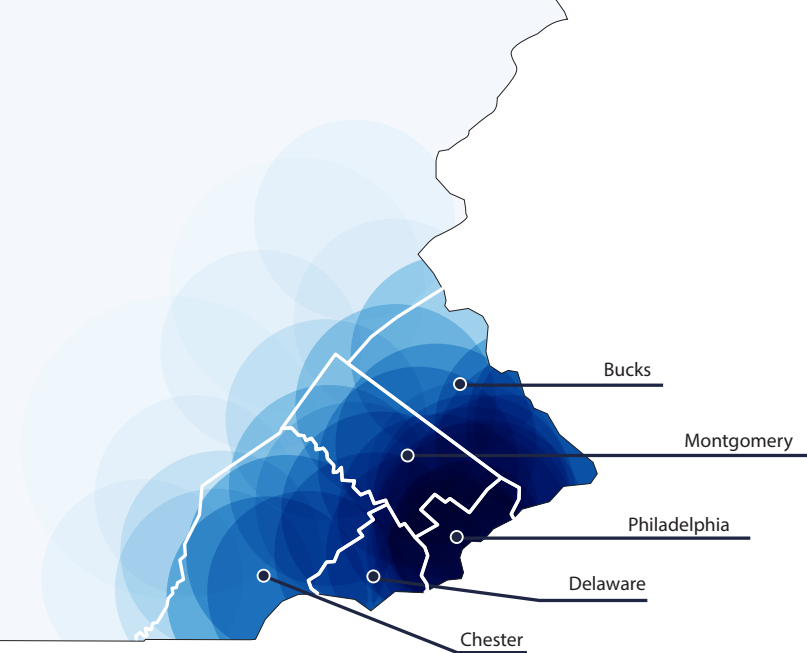

\$830 in savings per household each year

Transit is an economic equalizer that preserves affordability and access to opportunity in a growing region, serving as an important catalyst for an equitable future. In the City of Philadelphia, the average household saves \$830 per year on transportation household spending, a net financial benefit associated with proximity to high-quality transit.

GHG emissions are >10% below national average

Public transit is inherently sustainable: SEPTA Metro and Regional Rail emit less than half as many greenhouse gasses per passenger mile as a single-occupancy car. Transportation is the largest source of carbon emissions in the U.S., accounting for 28% of all emissions. In Philadelphia, transportation only represents 25% of carbon emissions thanks to a culture of low and no-carbon travel, including mass transit.

10x to 18x safer than driving

Riding transit is safer than driving—by many multiples. As transit use increases, traffic fatalities decrease—bus and rail transit are 10 times safer than driving while Regional Rail is 18 times safer than driving. Transit usage is a critical component of the region's Vision Zero initiatives to eliminate deaths and serious injuries resulting from traffic crashes.

OUR STATE-OF-GOOD-REPAIR BACKLOG IS MORE THAN NUMBERS ON PAPER.

As a legacy agency, we work hard to keep the systems we inherited running everyday while modernizing them to meet the needs of our region. We are rehabilitating bridges, upgrading power supply systems, and rebuilding stations to support a 21st century transit system; however, our state-of-good-repair-backlog outpaces funding levels, which means that we need to prioritize our most urgent needs. The backlog has grown to \$5.1 billion, up from \$4.6 billion, largely due to the impacts of inflation on the cost of materials and construction.

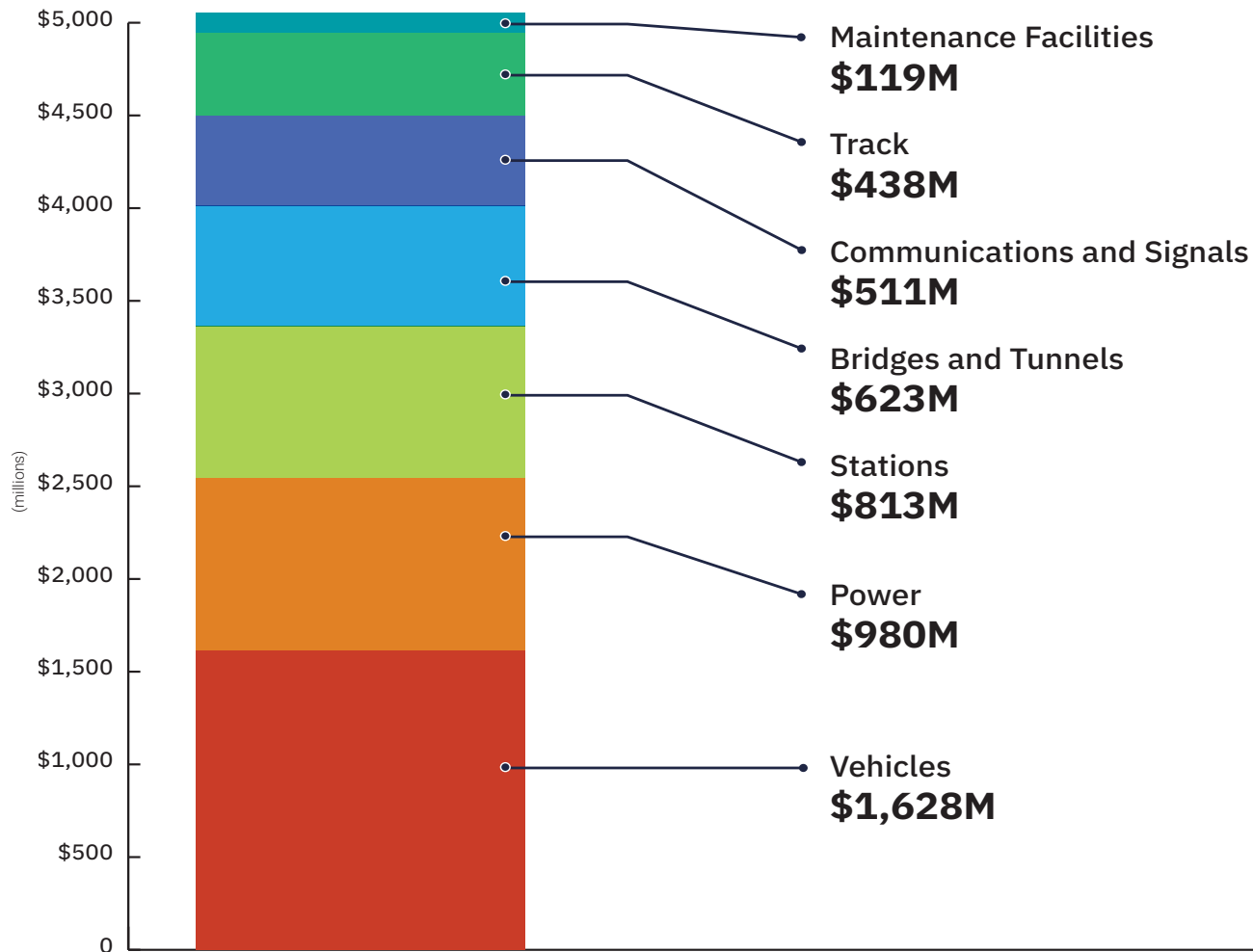

More than 30% of SEPTA's backlog of state-of-good repair is vehicles.

SEPTA has one of the oldest rail fleets in the country—and we're doing everything we can to keep our vehicles up and running. We inspect them regularly, run robust maintenance programs, and completely overhaul them every few years—but these efforts can only go so far.

Most of our Regional Rail cars are almost 50 years old—they started running while President Nixon was still in office. Our trolleys were built over 40 years ago, before important accessibility requirements were standard practice. Vehicles on the Market-Frankford Line, which carry more people than any other line in our system, are already almost 25 years old.

These vehicles are the anchor of our system—everything that we do to keep the region moving relies on them. That's why our Capital Program invests in more reliable, modern vehicles that will run smoother, increase reliability, and improve accessibility for all.

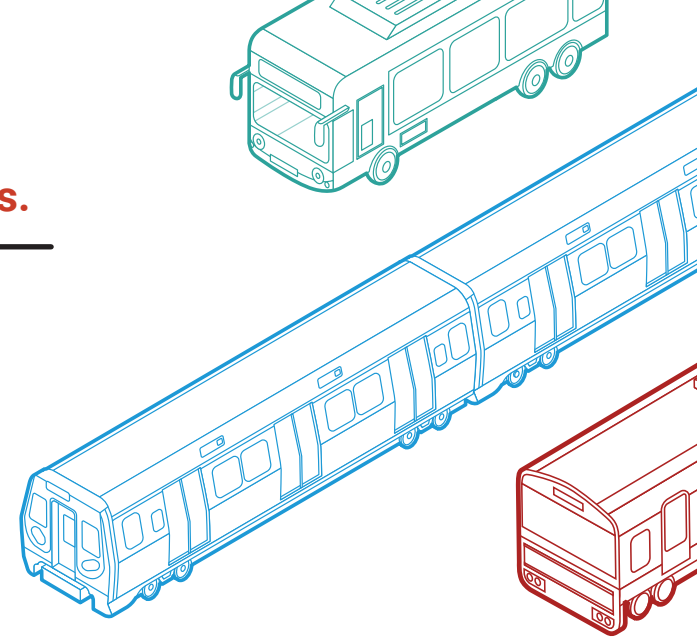

SEPTA FORWARD

SEPTA Forward, our strategic plan, is the framework to transform our organization and services to meet the changing needs of our riders. It sets a clear vision for the future with transit at the core of a resilient, prosperous, and equitable, community for everyone because **SEPTA is more than transit; it is the way we connect to each other.**

THREE PROJECTS, ONE NETWORK, ONE VISION

SEPTA Forward established three major initiatives to help us build towards our vision. While each initiative is focused on crunching the numbers, involving the public, and making data-driven recommendations for improvement, this Capital Program lays the groundwork to bring this vision to reality through these three programs.

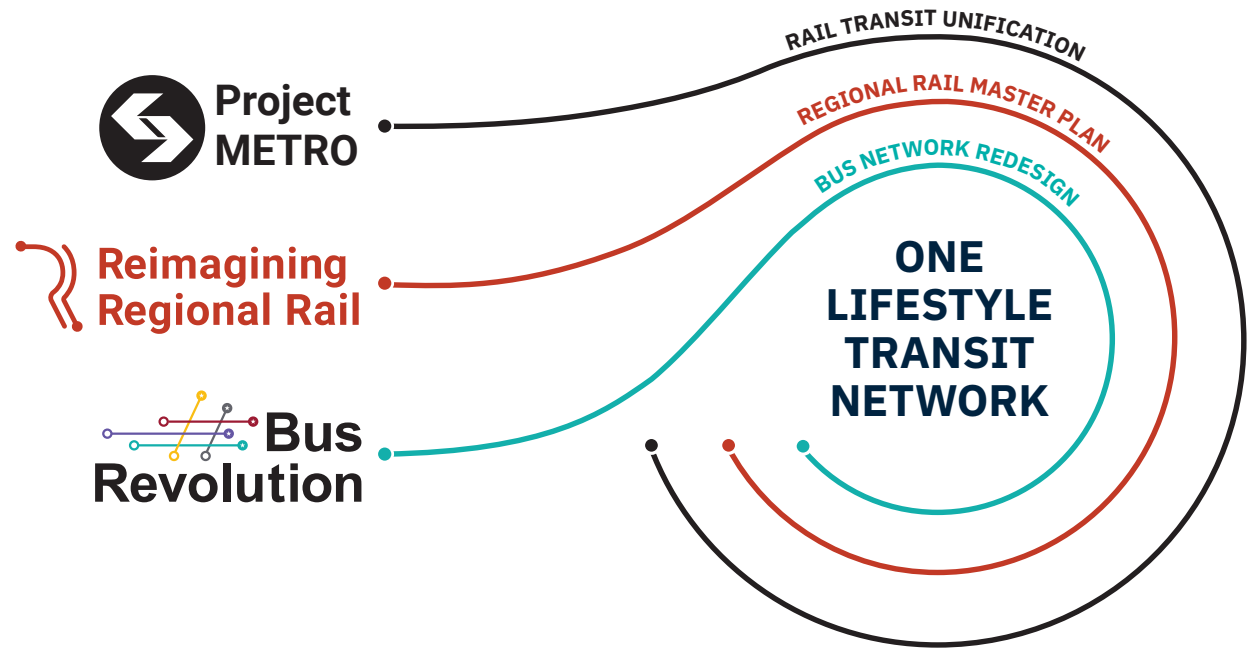

WE'RE RETOOLING OUR HISTORIC TRANSPORTATION SYSTEM TO SERVE EVERY TYPE OF TRIP— MORE THAN 9-TO-5 TRIPS TO WORK.

That's why we are creating a unified, lifestyle transit network. One that can be easily used for any sort of trip – whether that be traditional 9-to-5 commutes, reverse commuting, heading to school, shift work, everyday errands, or leisure activities. Transit does the most good when it is convenient and reliable enough to be used for a variety of needs, connecting more people to more jobs, reducing carbon emissions, making car ownership unnecessary, and improving quality of life for everyone.

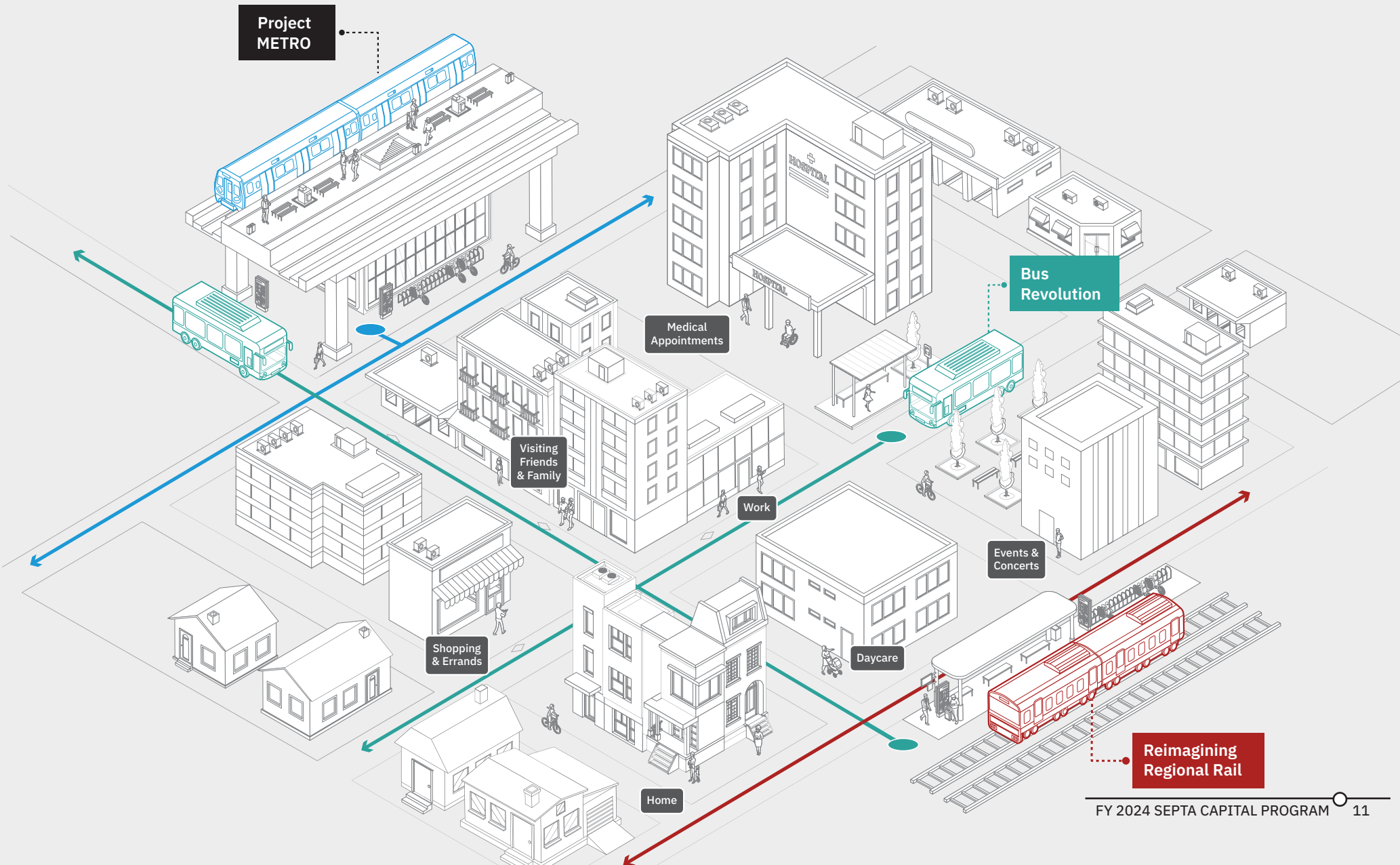

PROVIDING AN INTUITIVE + SEAMLESS EXPERIENCE

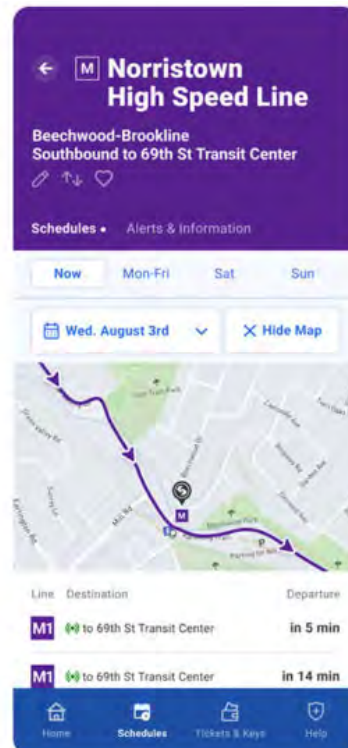
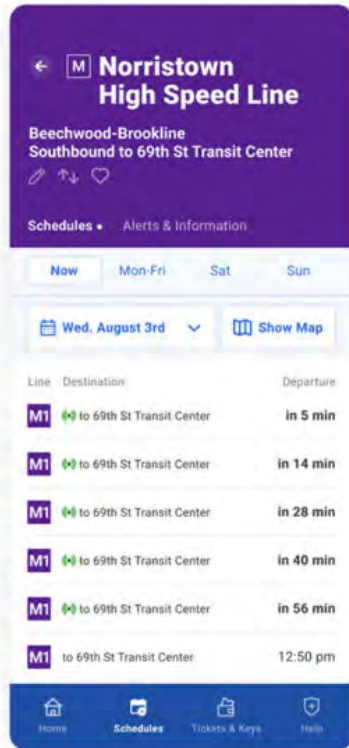
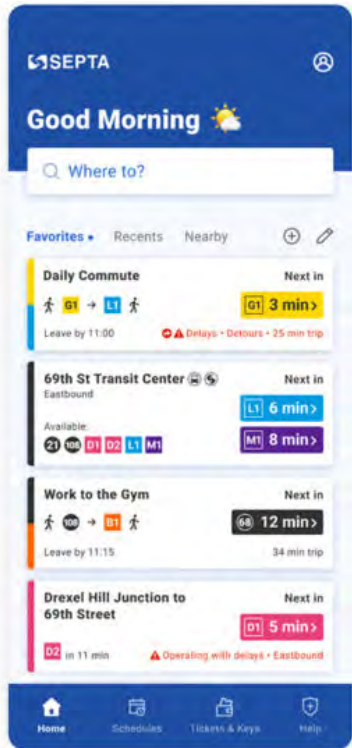

The vision put forth by SEPTA Forward is based on providing an intuitive experience and a seamless transit network. That means making our system easy-to-use for all, providing convenient services and the right information at the right time, for a smooth and enjoyable journey. In the last year, new temporary signage to improve wayfinding and information has gone up in Erie, Jefferson, and the concourse.

More than just physical signage, SEPTA will be launching a new, modern SEPTA.org website, and a completely redesigned mobile app. These changes will include an improved trip planner, better schedules, and an accessible design built around providing real-time information.

- Overhauling our wayfinding system to improve trips from beginning to end.
- Advancing SEPTA Key by adding smartphone and contactless credit card capabilities for more seamless fare payment.
- Modernizing Audio-Visual Public Address (AVPA) equipment to communicate arrivals and service changes with riders.
- Enhancing lighting and visibility at stations and facilities to improve safety and security.
- Improving real-time information reliability so you know exactly when your ride arrives.

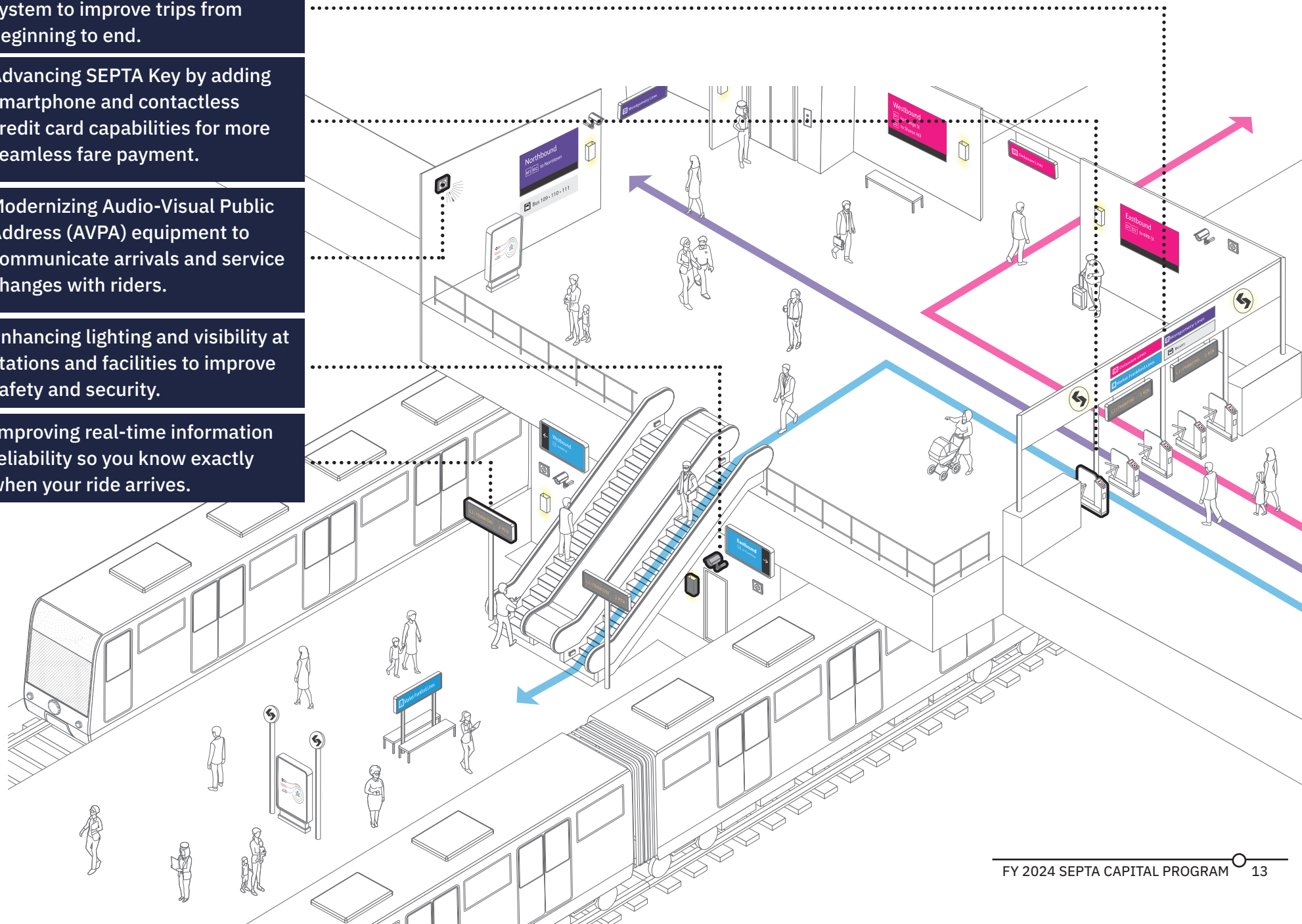

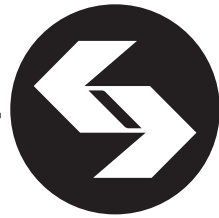

Project

METRO **L** **B** **M** **T** **G** **D**

A TRANSFORMATIONAL INVESTMENT IN OUR RAIL TRANSIT NETWORK

We're unifying the Market-Frankford Line, Broad Street Line, Norristown High Speed Line, and the routes 10, 11, 13, 15, 34, 36, and 101 and 102 as a single, easy-to-use network with new maps, signage, and communication: the SEPTA Metro. Our goal is to make these vital lines accessible and easy to use no matter who you are, or how well you know SEPTA.

More than wayfinding, "Project Metro" is how we can work together to create a modern, best-in-class frequent rail transit network. From Trolley Modernization's new stations and accessible vehicles to the procurement of new vehicles on the Market-Frankford Line, and accessibility improvements at major bus & Regional Rail network connection opportunities including like 30th Street and along the Broad Street Line, Project Metro will ensure that these projects are working together to meet the same goals.

Project Goals

1. Increase and improve access to opportunity.
2. Prioritize an intuitive, accessible journey from start to finish.
3. Create a visible, prominent transit system that is seen as the front door to the region.



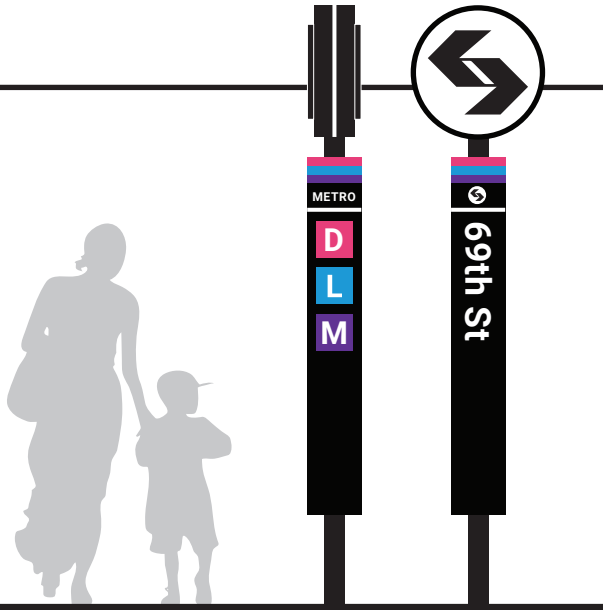

MAKING TRANSIT EASY TO USE FOR EVERYONE

SEPTA is working to provide riders with the right information, in the right place, at the right time. In early 2024, SEPTA will begin implementing the Wayfinding Master Plan by redesigning and replacing over 200,000 signs on the Metro network.



BUILDING AN ACCESSIBLE METRO

In recent years, SEPTA completed accessibility projects at 40th Street, 15th Street, and Arrott Transportation Center on the Market-Frankford Line. Additional work is underway at Susquehanna-Dauphin Station on the Broad Street Line and 30th Street Station serving both the Market-Frankford Line and City Trolleys, while design work continues on improvements at Tasker-Morris Station on the Broad Street Line and 11th Street Station on the Market-Frankford Line.

Thanks in part to additional federal infrastructure funding, **SEPTA is investing more than \$600 million to continue to focus on our commitment to make all stations on the Broad Street Line and Market Frankford Line accessible within the next decade.** These investments make the system easier to use and more accessible for all, including seniors, anyone with mobility disabilities, and those with baby strollers or groceries.

99%
of SEPTA Metro trips will be through
an accessible station by 2035
compared to 61% today.

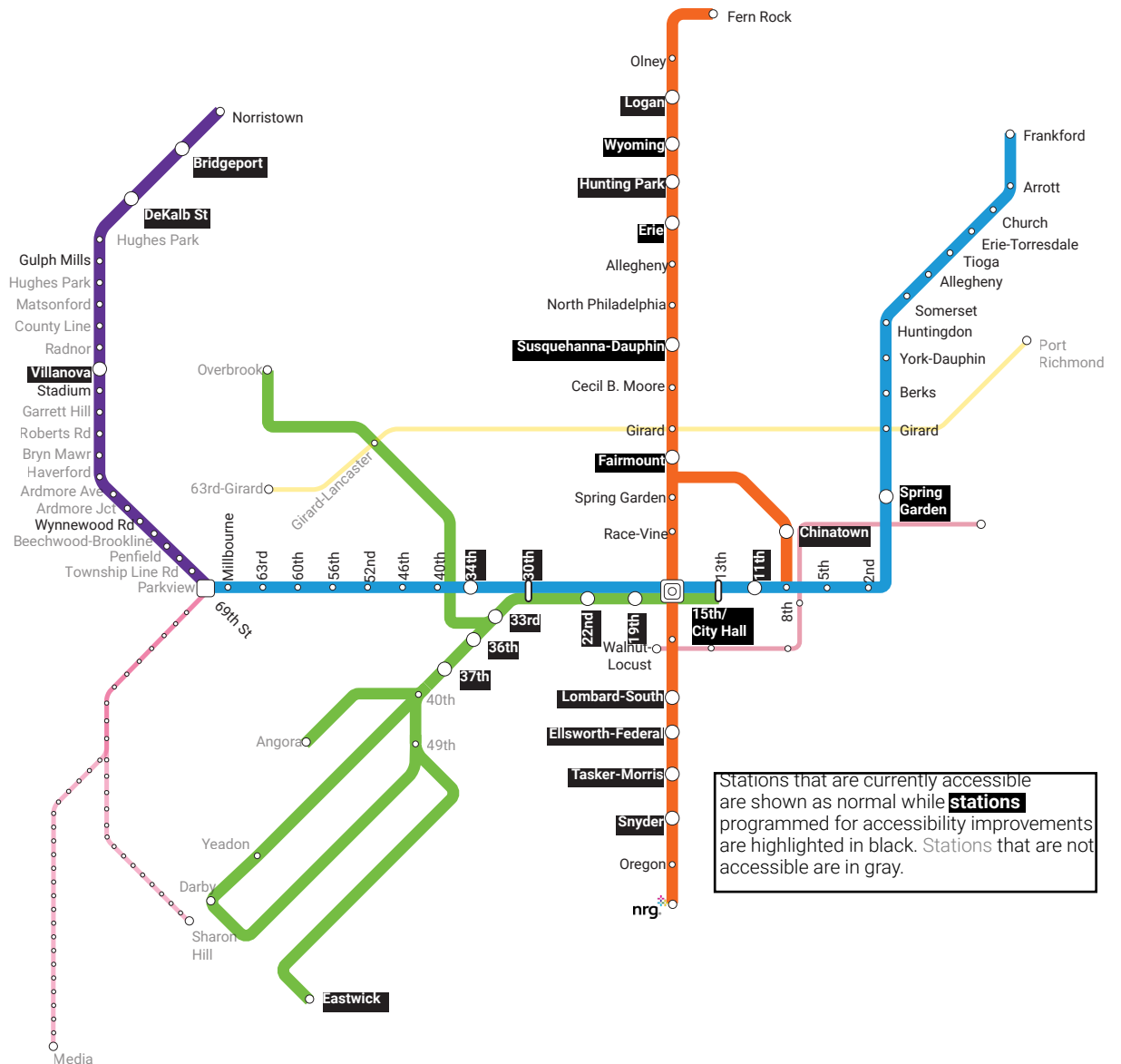

NEW VEHICLES FOR OUR MOST USED LINE

SEPTA's Market-Frankford Line is the workhorse of our system, connecting to every other Metro line, the entire Regional Rail system, and nearly half of our bus routes. However, the M-4 vehicles that provide this service day in and day out are now 25 years old and require more and more maintenance every year to keep them running. In order to continue providing reliable service on this line, **we're investing \$800 million in modern vehicles and \$150 million in an upgraded signal system to support greater frequency of service.**



Trolley Modernization

Trolley Modernization is a once in a generation opportunity to transform the nation's largest trolley network, delivering benefits across the region. Trolleys have played a critical role in our region since the early 1900s. The current vehicles have served communities since the 1980s, but need to be replaced with modern, accessible vehicles and stations. **SEPTA is committing more than \$1.633 billion to transform trolleys to meet the needs of riders today and tomorrow—that means faster and easier to use service for everyone.**

Trolley Modernization includes:

New, longer vehicles that hold more passengers and feature low floors and ramps, wider pathways, audio and visual messaging systems, and designated open space for people with wheelchairs, walkers, and strollers.

New on-street stations that are well-marked, safe, and fully accessible. Rebuilt existing stations are fully accessible with improved amenities.

Infrastructure + operational improvements to facilities, signals, & stations to make service faster and more reliable.

Proposed line extensions to make it easier for riders to reach more destinations, connect to more SEPTA services, improve operations, and have more room for passenger and operator amenities.



CORRIDOR PLANNING

SEPTA, in partnership with the Philadelphia Industrial Development Corporation (PIDC) and the City of Philadelphia, recently completed a study that identifies the best approach for incorporating Trolley Modernization station improvements for the Route 36 (T5) with all modes and users on Grays Avenue and Lindbergh Boulevard.



STATION DESIGN

SEPTA progressed conceptual design of new on-street station facilities—one of the most transformational and substantial projects of the Trolley Modernization program. The conceptual designs were developed based on feedback received from current riders and show how new station facilities will fit within various communities and accommodate new vehicles with accessible, level boarding.





Bus Revolution

A COMPLETE BUS NETWORK REDESIGN

Buses are the lifeblood of the SEPTA system. They carry nearly half of all SEPTA riders and make up the majority of “service hours” across our region. While our bus network is rooted in history, with many of our buses running on the same routes that started out as streetcar and trolley lines a century ago, the way we travel now has changed a lot. Bus Revolution will redesign the bus network to better match how people travel, aligning services with changes to the city and region, simplifying bus routes to improve system legibility, and increasing operational efficiency and effectiveness through improved speed and reliability.

Project Goals

1. Increase and improve access to opportunity.
2. Prioritize an intuitive rider experience through a seamless, simplified system.
3. Create a reliable, predictable system that people can trust.



PARTNERSHIPS ARE CRITICAL

We can't make bus service faster and more reliable alone. Many of the opportunities to improve speed and reliability include work along public streets, such as introducing transit-only lanes, prioritization at signalized intersections, and even improved bus stop platforms. These improvements require help from the communities where buses operate, such as the City of Philadelphia, and other partners like the Pennsylvania Department of Transportation (PennDOT)—that's why we are committed to working with them to invest in bus infrastructure and complete streets projects across our region.

This Capital Program commits more than \$150 million to infrastructure improvements designed to complement the service changes made through Bus Revolution to make our transit network more seamless and reliable.



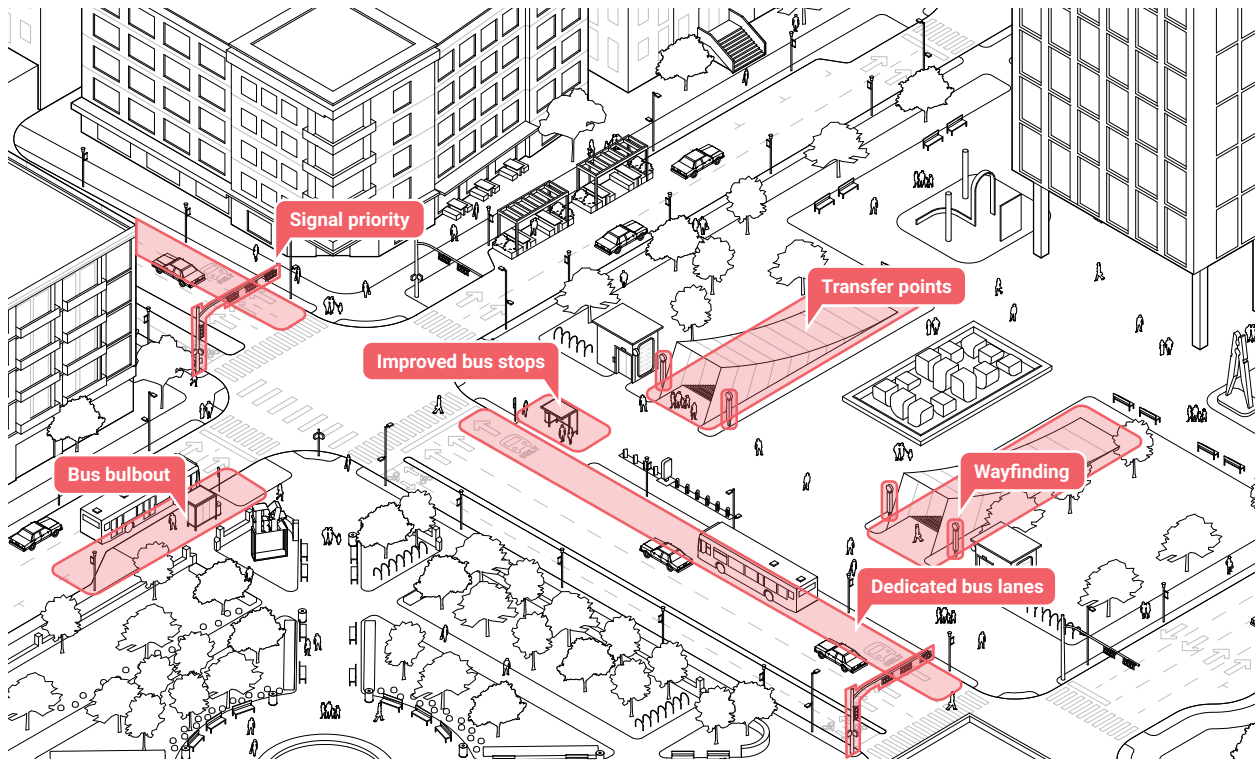

PRIORITIZING TRANSIT ON OUR STREETS

The analysis we completed for Bus Revolution revealed that the biggest opportunities to strengthen the bus system are improving speed and reliability. That's not surprising—when buses are stuck in congestion it means longer trips with more frequent delays for riders. In similar cities across the country, buses move at an average speed of 13 to 14 mph, but in the City of Philadelphia, buses average only 8 mph—that's over 40% slower!

Transit priority measures help buses move more quickly along streets and through intersections. That could mean dedicated bus lanes along certain streets or special traffic lights that prioritize transit ("transit signal priority") and lanes that let buses bypass car traffic ("queue jump lanes") at intersections. **SEPTA is committing \$45 million to these improvements and additional enhancements to bus stops, including real-time information and platforms, to create the strong foundation necessary for reliable and frequent bus service and address the top priorities of our riders.**



The new facility at the Wissahickon Transportation Center will improve connections and the waiting experience for riders and provide improved amenities for operators, such as bathrooms and break rooms.

○ IMPROVING END-OF-LINE FACILITIES

Improving bus end-of-line facilities is important for both riders and operators. SEPTA's end-of-line facilities are often where riders transfer to other bus lines and SEPTA services such as Metro and Regional Rail, and where riders are dropped off from carpools or shuttles to catch the bus. For operators, it's where they can take their break between trips. In many locations, SEPTA does not own these locations and frequently partners with nearby property owners to provide bathrooms for operators, but it's not always reliable for operators.

For our riders, improved end-of-line facilities mean we can provide a more consistent set of amenities at these locations—such as benches, shelters, real-time information screens, and maps—which is essential to making transit easy for everyone. It also means that we can provide more comfortable break rooms and bathrooms for our bus operators—the heroes we rely on to move people safely across our region. **This Capital Program dedicates \$70 million to designing and developing new end-of-line facilities across our bus network.**



MAKING TRANSIT EVEN MORE SUSTAINABLE ○ WITH ZERO-EMISSION BUSES

Although riding transit is already much more sustainable than driving, SEPTA is committed to transitioning away from diesel-powered buses and toward zero-emission buses (ZEBs) by the year 2040. ZEBs could include a combination of battery-electric buses (BEBs), fuel cell electric buses (FCEBs), and Trackless Trolleys. In addition to reducing SEPTA's carbon footprint, ZEBs contribute to regional and national greenhouse gas reduction goals and improve local air quality. Once SEPTA completes its current procurement of 220 hybrid buses, **SEPTA is investing between \$108 million and \$140 million every year between 2027 and 2035 to transition to a ZEB fleet as a part of our rolling bus replacement program.**

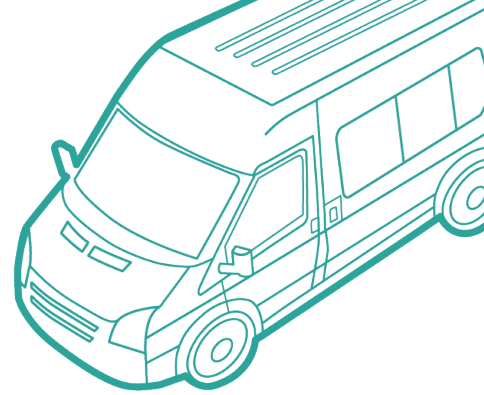

IMPROVING SERVICE WITH MICROTRANSIT

Microtransit is a flexible, on-demand transit service designed to serve low density, low ridership, and other difficult-to-service areas where access remains critical. It is the next generation of dial-a-ride, designed to maintain access while improving both rider experiences and operational efficiency. Redesigning the bus network through Bus Revolution creates an opportunity to introduce microtransit as part of a proposed family of services.

Microtransit zones will overlap with other fixed bus routes to unlock timely, efficient access in lower density and ridership areas to improve the experience for riders.



NEW DISPATCH SYSTEM MEANS MORE RELIABLE SERVICE

We know that reliable and accurate real-time information is key to improving riders' experience on SEPTA. **This Capital Program commits \$121 million to delivering a new Computer Aided Radio Dispatch (CARD) system to improve communications between operators, dispatchers, and the Control Center, ensuring that vehicles are on-time and service changes are clearly communicated with riders.**

This new CARD system will also generate accurate real-time information that will be shared with riders through our new Audio Visual Public Address signs and speakers, as well as on mobile devices.

Reimagining Regional Rail

REGIONAL RAIL THAT WORKS FOR EVERYONE

Everyone knows Regional Rail is great for commuting 9-to-5, but what if it could be more than that? Imagine Regional Rail service that is just as convenient on nights and weekends as it is at 5:00 PM, or that serves reverse commuters just as well as those headed to Center City. Imagine Regional Rail with better integration with Metro and buses. How would that change the way you travel? We see Regional Rail as part of a lifestyle network of frequent, all-day, and all-week services that connect people to a range of destinations across the region. Reimagining Regional Rail is a rider and data-driven process to create a vision of what that looks like, and identifying what it will take to get there. Everything is up for discussion—from schedules to vehicles, station amenities and signage.

Project Goals

1. Increase and improve access to opportunity.
2. Prioritize an intuitive rider experience through a seamless, welcoming system.
3. Create a reliable, predictable Regional Rail system that people can trust.

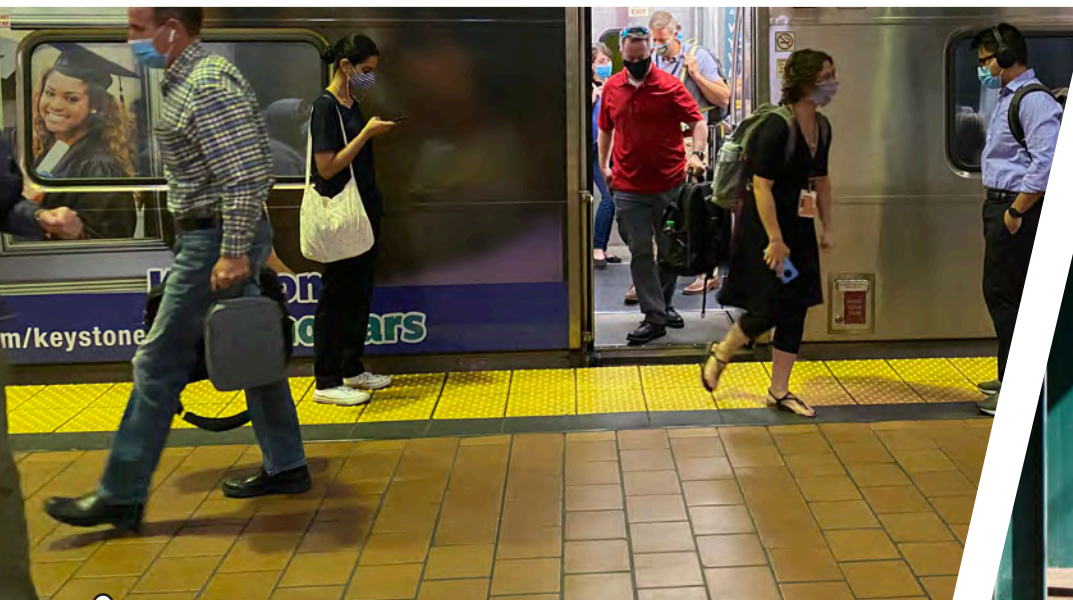

TRANSFORMING REGIONAL RAIL WITH NEW TRAINS

Since most of our Regional Rail vehicles started running back in the 1970s, improving service today and providing reliable service in the future requires new vehicles. Not only will these cars ensure that SEPTA can continue to provide reliable Regional Rail service, but these new cars will dramatically improve the rider experience.

The new cars will be fully accessible to people with disabilities and include passenger amenities such as an enhanced climate control system, bicycle storage, and WiFi—as well as communications tools essential to integrating Regional Rail with the SEPTA Metro and bus network. This includes exterior and interior destination signs, audio announcements and corresponding displays on video screens. SEPTA is committing \$650m towards replacing the Silverliner IV vehicles—the oldest in our fleet—and is in the process of develop fleet goals that support that vision of Reimagining Regional Rail.



MAINLINE-SCHUYLKILL BRIDGES

When the Center City Commuter Connection Tunnel was built in the early 1980s to connect the Pennsylvania and Reading Railroads, it created the only fully electrified, through-running railroad in North America and the heart of SEPTA's Regional Rail network. With every Regional Rail line using this stretch of track, the underlying infrastructure plays a crucial role in our ability to provide reliable and frequent service. While the connection between Suburban Station and Jefferson Station consists of modern infrastructure, the seven bridges between Suburban Station and 30th Street Station were originally built in 1929 and require significant rehabilitation. SEPTA will rehabilitate these bridges over the next 11 years while phasing the work to keep service running.

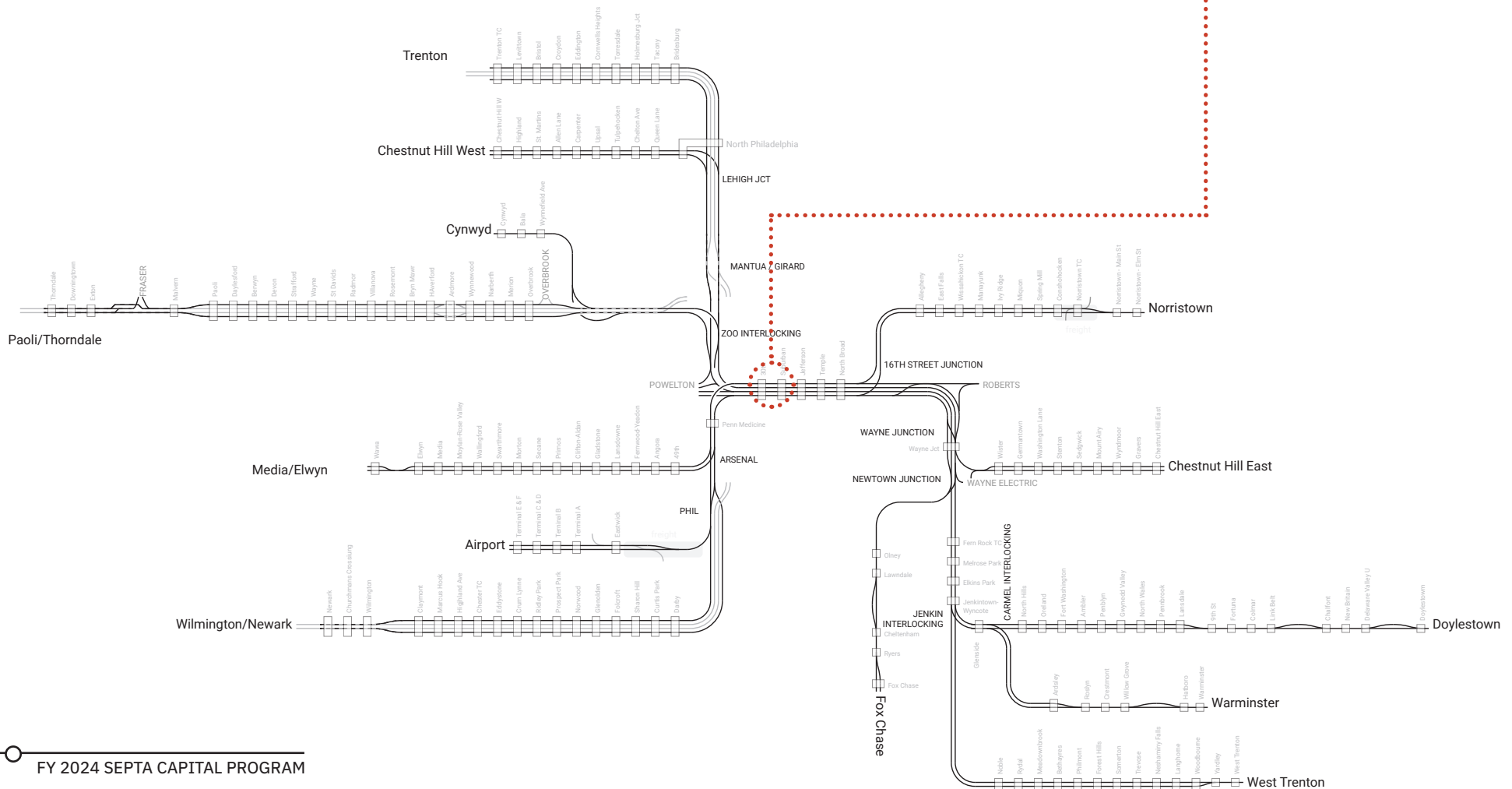
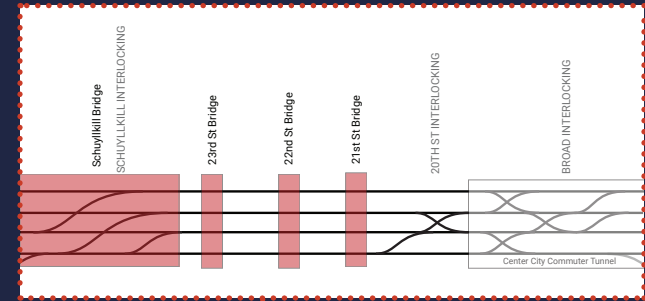

● INTERLOCKINGS

Interlockings allow trains to cross from one track to another and are essential to delivering reliable and on-time service, particularly on Regional Rail where all of the lines converge through Center City. **This Capital Program commits \$187 million to enhancements and modernization of railroad interlockings to improve operational efficiency at key junctions across the system.**



● BUILDING ACCESSIBLE AND COMFORTABLE STATIONS

Stations are the front door to SEPTA's Regional Rail system and form the foundation of an intuitive and seamless network. **We are investing more than \$450 million on continued efforts to modernize Regional Rail stations across our system to make them fully accessible and provide seamless connections to the rest of the SEPTA Metro and bus network.**

Upgraded stations will have high-level platforms that make Regional Rail service accessible to people with disabilities and easier to ride for seniors, small children and their families, and anyone who needs a little more help to get where they are going. These high-level platforms also reduce the time it takes to board—speeding up service for everyone. SEPTA is also ensuring that upgraded stations feature modern amenities that make riders' journeys easier, such as enhanced real-time information screens.



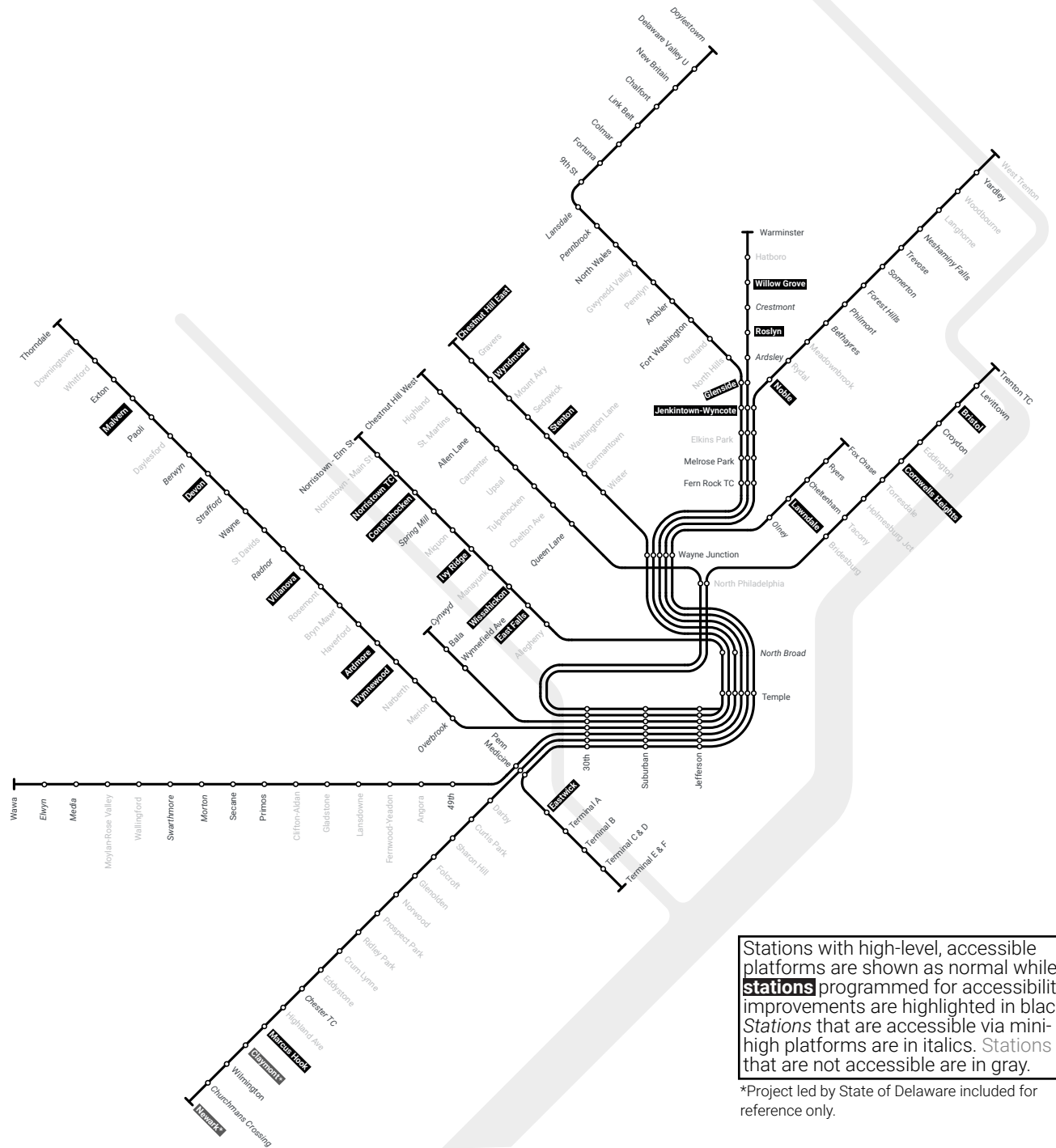

Stations with high-level, accessible platforms are shown as normal while **stations** programmed for accessibility improvements are highlighted in black. *Stations* that are accessible via mini-high platforms are in italics. Stations that are not accessible are in grey.

*Project led by State of Delaware included for reference only.

PROPOSED FY 2024 CAPITAL BUDGET AND
FY 2024 – 2035 CAPITAL PROGRAM

CAPITAL FUNDING



PROPOSED FY 2024 CAPITAL BUDGET AND FY 2024 – 2035 CAPITAL PROGRAM

SEPTA's FY 2024 Capital Budget totals **\$976.79 million** and the FY 2024 – 2035 Capital Program totals **\$12.6 billion**. This amounts to the largest capital commitment the Authority has made in its history. These historic funding levels are made possible by increased federal funding resulting from the November 2021 enactment of the Infrastructure Investment and Jobs Act (IIJA), also referred to as the Bipartisan Infrastructure Law (BIL), and the transition of Pennsylvania Act 89 Public Transportation funding sources from reliance on Pennsylvania Turnpike Commission bonds to the state's Motor Vehicle Sales and Use Tax. The infusion of federal capital assistance, along with the transition of state funding to a sustainable and bondable funding source allows SEPTA to address its \$5.1 billion state of good repair backlog while planning for future service improvements to ensure capital dollars are invested to advance equity, safety, ADA accessibility, and service reliability.

With the transition of state funding to a sustainable and bondable source, SEPTA is able to leverage against forecasted state revenues to issue bonds to support critical capital investments. These projected bond revenues significantly increase the Authority's capital program, allowing it to address the critical state of good repair backlog earlier, including supporting the acquisition of new vehicles to replace the nation's oldest railcar fleet.

Also supporting SEPTA's capital program is a transformative commitment of \$299.72 million in federal Congestion Mitigation and Air Quality program (CMAQ) flex funds beginning in FY 2025, supported by our local partners the City of Philadelphia and Bucks, Chester, Delaware, and Montgomery Counties and the Delaware Valley Regional Planning Commission. These additional flexed federal highway dollars enables SEPTA to commit significant dollars to advancing its Projects of Significance.

SEPTA continues to work with local funding partners to identify additional regional funding to help leverage and maximize federal and state resources to address SEPTA's capital needs.



Susquehanna-Dauphin Station



Conshohocken Station

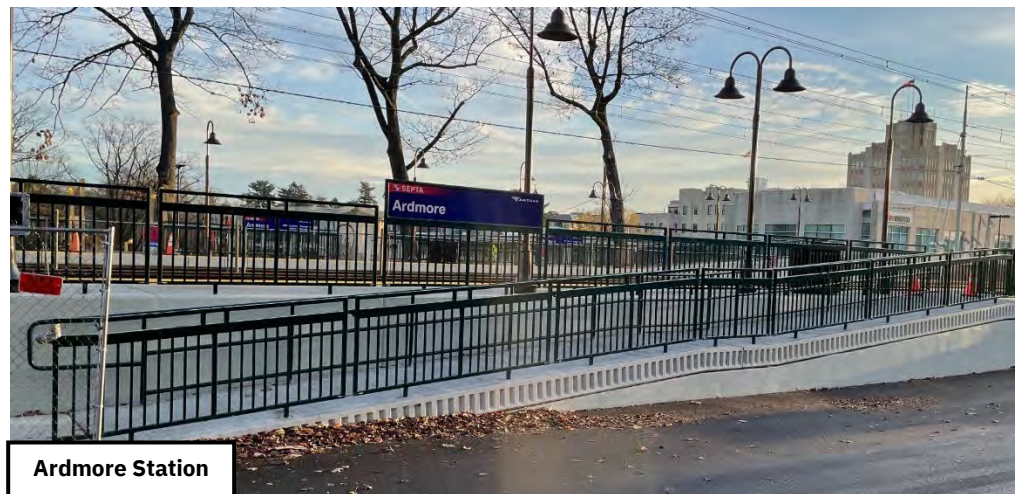

Ardmore Station

PROPOSED FY 2024 CAPITAL BUDGET AND FY 2024 – 2035 CAPITAL PROGRAM

FY 2024 - 2035 Capital Program / Financial Obligations (\$ Millions)	Prior Funding	Budget Year	Program Years				FY 2029 - 2035	12-Year Program Total
		Year FY 2024	FY 2025	FY 2026	FY 2027	FY 2028		
Capital Programs								
Bridge Program	\$46.15	\$15.55	\$20.23	\$30.43	\$30.14	\$26.92	\$176.61	\$299.88
Communications, Signal Systems and Technology	\$447.62	\$100.23	\$105.19	\$81.23	\$90.95	\$88.67	\$461.15	\$927.42
Infrastructure Safety Renewal Program	\$0.00	\$60.46	\$61.67	\$62.91	\$64.16	\$65.44	\$496.26	\$810.90
Maintenance/Transportation Shops and Offices	\$201.64	\$77.51	\$74.81	\$53.39	\$35.86	\$33.13	\$171.10	\$445.79
Projects of Significance: Early Actions	\$268.01	\$213.01	\$217.25	\$218.86	\$380.34	\$294.80	\$1,807.17	\$3,131.43
Safety and Security Improvements	\$144.23	\$50.53	\$50.28	\$31.98	\$33.33	\$32.06	\$170.73	\$368.92
SEPTA Key	\$321.45	\$9.12	\$40.00	\$45.00	\$45.00	\$40.00	\$54.67	\$233.79
Service Restoration	\$0.00	\$1.00	\$1.00	\$0.00	\$0.00	\$0.00	\$0.00	\$2.00
Stations, Loops and Parking Improvements	\$425.46	\$86.99	\$96.52	\$105.27	\$111.24	\$101.73	\$462.67	\$964.42
Substations and Power Improvements	\$137.05	\$30.55	\$38.13	\$52.47	\$70.59	\$60.30	\$181.41	\$433.46
Track and Right-of-Way Improvements	\$68.58	\$20.42	\$10.77	\$9.38	\$17.61	\$17.50	\$17.52	\$93.20
Vehicle Acquisitions and Overhauls	\$546.56	\$206.71	\$101.39	\$135.19	\$222.66	\$222.77	\$1,652.44	\$2,541.16
Financial Obligations								
Capital Leases	\$90.00	\$30.16	\$37.40	\$39.45	\$71.56	\$73.72	\$574.32	\$826.61
Debt Service	\$0.00	\$74.54	\$74.54	\$74.55	\$99.45	\$126.86	\$1,076.31	\$1,526.25
	\$90.00	\$104.71	\$111.94	\$113.99	\$171.01	\$200.58	\$1,650.63	\$2,352.86
Total Capital Budget & Program	\$2,696.76	\$976.79	\$929.18	\$940.11	\$1,272.89	\$1,183.90	\$7,302.36	\$12,605.23

PROPOSED FY 2024 CAPITAL BUDGET: SOURCES OF CAPITAL FUNDING

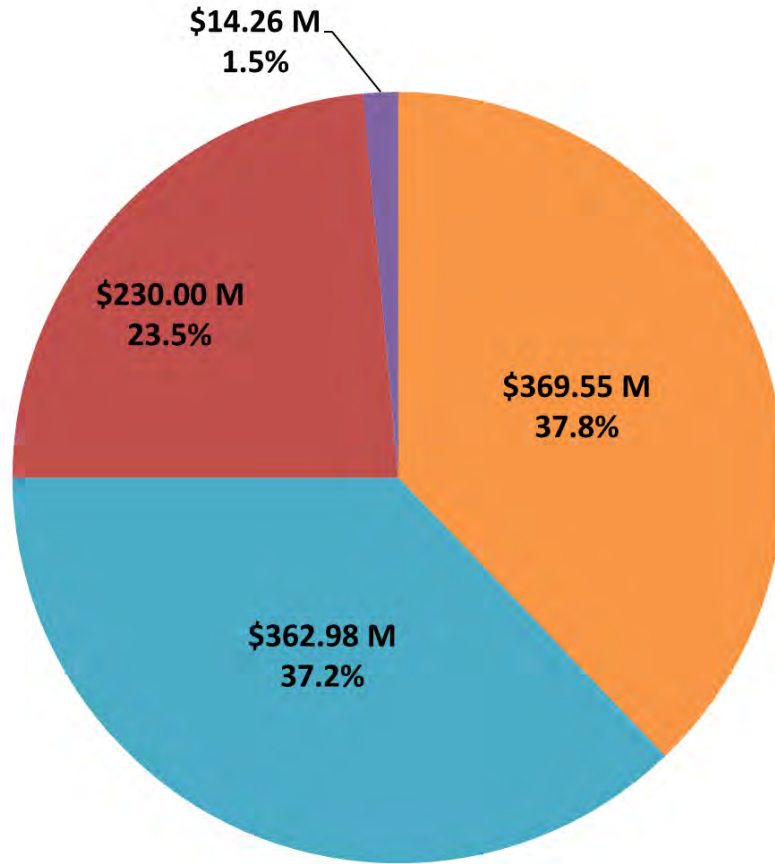

Total: \$976.79M

\$369.55 million in state funding

\$362.98 million in federal funding

\$230.00 million in capital financing bond revenues

\$14.26 million in local funds

PROPOSED FY 2024 CAPITAL BUDGET: SOURCES OF CAPITAL FUNDING

STATE FUNDING: \$369.55 MILLION

SEPTA's FY 2024 Capital Budget includes \$369.55 million in state funding from PennDOT.

The Section 1514 program provides most of the state funding for SEPTA's capital program. These funds directly support SEPTA capital projects as well as provide the state's match commitment to federally funded projects. SEPTA also receives state funding from other programs on a periodic basis, including the PA Department of Environmental Protection.

The Section 1514 program supports 96.775 percent of the total cost of state funded projects. The remaining 3.225 percent of the total cost is matched by Bucks, Chester, Delaware and Montgomery Counties and the City of Philadelphia. SEPTA also uses these state resources to match federal grants, with the state share comprising 96.775 percent of the non-federal local match commitment (generally a total project share of 19.355 percent).

Further, as these dollars are no longer sourced from Pennsylvania Turnpike Commission bonding, SEPTA was able to issue bonds in the amount of \$550 million in October 2022 to support numerous capital projects and restructure prior debt. Going forward, SEPTA plans to leverage a portion of the funding it receives from PennDOT to establish a multi-year bonding program to fund capital improvement projects within this capital budget and 12-year capital program. Additional information is included in the Financial Obligations Section.

FEDERAL FUNDING: \$362.98 MILLION

SEPTA's FY 2024 Capital Budget includes an estimated \$362.98 million in federal funds.

Most of SEPTA's federal funding is provided by grants from the U.S. Department of Transportation's Federal Transit Administration (FTA) via formula funding programs. These programs provide predictable annual funding to SEPTA's capital program and received significant nationwide annual funding increases via the Infrastructure Investments and Jobs Act (IIJA) which establishes federal funding levels for the next five years. The IIJA provides SEPTA an increase of approximately \$100 million per year above federal funding levels in the previous authorization bill. This infusion of federal capital assistance provides SEPTA the opportunity to leverage federal formula funding to address critical state of good repair needs and begin to advance ADA accessible rail station projects sooner than previously planned.

SEPTA also receives federal highway Congestion Mitigation and Air Quality (CMAQ) funds that PennDOT "flexes" (i.e., transfers) to transit agencies in the Commonwealth. SEPTA anticipates to receive \$17 million from this program in FY 2024 to support the Bus Purchase Program (\$17M). Through the adoption of the FY 2023-2026 Transportation Improvement Program for Pennsylvania, the regional partners (including Bucks, Chester, Delaware and Montgomery Counties and the City of Philadelphia) elected to allocate \$299.79 million of the Philadelphia region's CMAQ program dollars to support SEPTA's Projects of Significance. This Regional investment in transit is an investment in our climate, equitable access to opportunities, public health and safety, and regional economic strength.

PROPOSED FY 2024 CAPITAL BUDGET: SOURCES OF CAPITAL FUNDING

Federal formula funds typically support 80 percent of the total cost of a capital project; the remaining 20 percent local match is provided by the Commonwealth of Pennsylvania, the City of Philadelphia and Bucks, Chester, Delaware, and Montgomery Counties. Competitive grants may require a different matching share but these vary based on the matching commitment of specific competitive awards.

The FY 2024 budget proposal also includes \$1 million in projected Transit Security Grant Program (TSGP) funds allocated through competitive grants administered by the Federal Emergency Management Agency (FEMA).

SEPTA also regularly applies for federal competitive grants when available. In the past year, SEPTA was selected to receive \$56.05 million to support ADA Accessibility Improvements to the 11th Street, Snyder, Chinatown, Fairmount, & Erie Stations via FTA’s All Stations Accessibility Program, and \$23.36 million from the FTA Low or No Emission Vehicle Program to support power resiliency upgrades at Allegheny, Callowhill, & Comly Bus Depots. Both projects are integral to the success of our goals of providing a fully accessible rail transit system and transitioning to a zero-emission bus fleet.

FY 2024 Capital Budget: Federal Formula and Flex Funding Estimates		
Program	Description	Amount (Millions)
FTA Section 5307	Urbanized Area Formula Program. Funds transit capital projects. Allocations based on population, density, operating expenses, revenue miles and route miles.	\$141.65 M
FTA Section 5340	Growing States and High Density States Formula Program. Allocations based on population forecasts and population density. SEPTA receives Growing States program funding.	
FTA Section 5337	State of Good Repair Program. Funds High Intensity Fixed Guideway (rail) and High Intensity Motorbus capital projects. Allocations based on vehicle revenue miles and route miles.	\$194.73 M
FTA Section 5339	Bus and Bus Facilities Formula Program. Funds capital projects to replace, rehabilitate or purchase buses and related facilities. Allocations based on population and service factors after providing a minimum amount per state.	\$8.52 M
Highway Flex	Federal highway program funds that PennDOT provides to state transit agencies for capital improvement projects. Based on the Governor’s commitment, a minimum of \$25 million per year is flexed annually to transit operators.	\$17.08 M
Transit Security Grant Program	Competitive grant program administered by Federal Emergency Management Agency (FEMA). Provides funds for anti-terrorism, safety and security improvements, and operational activities such as directed patrols.	\$1.00 M
Total Federal		\$362.98 M

PROPOSED FY 2024 CAPITAL BUDGET: SOURCES OF CAPITAL FUNDING

LOCAL FUNDING: \$14.26 MILLION

The local funding contributions to SEPTA's FY 2024 Capital Budget is \$14.26 M. These local contributions are required to match state and federal grant funds and are provided by the City of Philadelphia and Bucks, Chester, Delaware, and Montgomery Counties. SEPTA requests capital assistance from the City of Philadelphia as part of the City's capital budget process. Capital assistance is requested from the four counties concurrent with the annual operating budget subsidy request.

CAPITAL FINANCING: \$230.00 MILLION

With the transportation dollars that SEPTA receives from PennDOT transitioning to Motor Vehicle Sales and Use Tax revenues, a bondable funding source, SEPTA issued bonds in the amount of \$550 million to support capital projects in October 2022. Of this amount, \$230 million is programmed in FY 2024 to support multiple station accessibility, bridge, signal, and power projects along with Trolley Modernization. SEPTA has already utilized \$240 million to refinance outstanding debt and anticipates an additional \$80 million will be spent through FY 2023 to fund capital projects.

State & Local Funding Leverages Additional Investments

The federal IIJA provides significant opportunities for SEPTA to address its state of good repair backlog, advance its Projects of Significance, and continue to invest in making rail stations ADA accessible.

To take full advantage of federal opportunities that will be made available in the next few years, significant State & Local resources are needed to leverage potential federal investments. Legislative action from Harrisburg is necessary to enable local investment options to leverage additional federal funding to advance the projects that drive local and regional priorities.

SEPTA estimates that an additional \$150 million in State & Local funding annually can leverage up to \$2 billion in additional federal infrastructure funding over the next decade. Some examples of federal funding programs that can be leveraged to the maximum extent with additional regional funding include:

- All Stations Accessibility Program
- Rail Vehicle Replacement Program
- National Infrastructure Project Assistance Program
- Low or No Emission Vehicle Program
- Rebuilding American Infrastructure with Sustainability and Equity (RAISE)

FUNDING ASSUMPTIONS

SEPTA's FY 2024 Capital Budget and FY 2024 – 2035 Capital Program is fiscally constrained and all projects in this budget reflect anticipated funding against forecasted funding levels.

The passage of the IIJA provides SEPTA with sustainable federal funding assumptions for FYs 2022 through 2026. In accordance with PennDOT funding assumptions, IIJA FY 2026 funding levels are carried forward from FY 2027 through FY 2035. The additional CMAQ funding negotiated at the regional level continues through FY 2034. Due to the unprecedented competitive funding created in the IIJA for transit systems and SEPTA's recent and historical success with these opportunities, SEPTA has programmed \$850 million of additional discretionary federal funding in FY 2025 through FY 2035. It is anticipated these funds will be secured through various competitive programs including the FTA All Stations Accessibility Program (ASAP), Rail Vehicle Replacement Program, Low or No-Emission Vehicle Program, Bus & Bus Facilities Program, Rebuilding American Infrastructure with Sustainability and Equity (RAISE), National Infrastructure Project Assistance Program (MEGA), the Capital Investment Grant (CIG) Program, and more.

State funding assumes an annual increase in funding per financial guidance distributed by PennDOT and the Delaware Valley Regional Planning Commission (DVRPC). With the transition of state public transportation support to the Motor Vehicle Sales and Use Tax, SEPTA and other providers of public transportation in the Commonwealth of Pennsylvania now have a sustainable and bondable long-term source of capital assistance. As approved by the Board, SEPTA leveraged these dollars to pursue an initial issuance in 2022 with subsequent planned annual bond issuances to support the capital program from FY 2027 through FY 2035.

For federal and state formula dollars, SEPTA assumes regular local match contributions from the City of Philadelphia and Bucks, Chester, Delaware and Montgomery Counties. Local match contributions to federal projects generally comprises 0.645 percent of total project costs for projects receiving federal assistance and 3.225 percent match to state funded projects. Local matching ratios may increase on a case-by-case basis to leverage future federal and state assistance to advance capital projects.

PROPOSED FY 2024 CAPITAL BUDGET: USES OF CAPITAL FUNDING

SEPTA’s FY 2024 Capital Budget totals \$976.79 million. Total FY 2024 spending is allocated among projects that will bring assets to a state of good repair, meet the Authority’s financial obligations, advance strategic objectives, and implement system improvements to enhance transit service. Due to the impacts of COVID-19, prior year funds are available to support Financial Obligations and Vehicle Acquisitions and Overhauls Programs costs in fiscal years 2024, 2025, and 2026. Therefore, less FY 2024-2026 funds are allocated to these projects than average. Additional details are provided in those sections of the document.

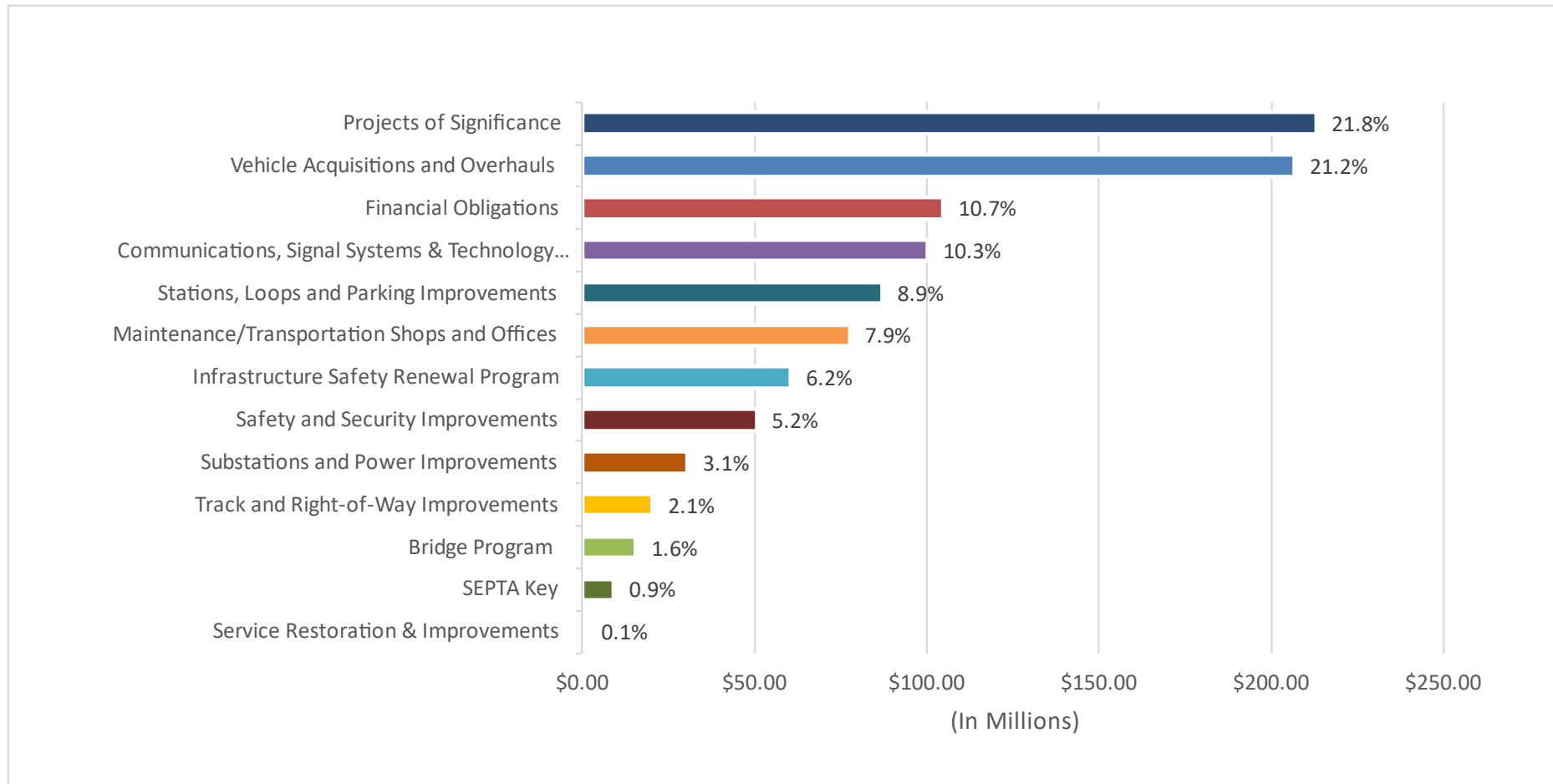

PROPOSED FY 2024 CAPITAL BUDGET AND
FY 2024 – 2035 CAPITAL PROGRAM

CAPITAL PROGRAM DESCRIPTIONS



BRIDGE PROGRAM

SEPTA owns and maintains more than 350 bridges. The majority of structures were constructed in the late 1800's and early 1900's. The bridge program consists of renewal and rehabilitation that will restore the structures to a state of good repair and extend their useful life. Highlights of the FY 2024 Capital Budget include the rehabilitation of the Bridgeport Viaduct, which carries the Norristown High Speed Line over the Schuylkill River, the Critical Bridge program, and the rehabilitation of bridges along the Chestnut Hill East and Chestnut Hill West Regional Rail Lines in Philadelphia.



Media/Elwyn Regional Rail Line Park Ave Bridge - Built

Bridge Program - Program Elements (\$ Millions)	Prior Funding	FY 2024	FY 2025	FY 2026	FY 2027	FY 2028	FY 2029-2035	12-Year Program Total	Total Budget
Regional Rail Bridge	\$39.43	\$11.20	\$18.53	\$16.65	\$17.70	\$26.92	\$176.61	\$267.61	\$307.04
Transit Bridge	\$6.72	\$4.35	\$1.70	\$13.78	\$12.44	-	-	\$32.28	\$39.00
Bridge Program Total	\$46.15	\$15.55	\$20.23	\$30.43	\$30.14	\$26.92	\$176.61	\$299.89	\$346.04



19th Century Stone Arch Bridges



Manayunk/Norristown Line Bridge MP 17.77 - Built 1900

Project Descriptions	Budget	Schedule / Status (Calendar Year)	Location	Service Area
Railroad Bridge Projects (FY 2024 – 2028)				
Chestnut Hill East Line Bridge Rehabilitation Program				
Rehabilitation of five bridges on the Chestnut Hill East Regional Rail Line located at: <ul style="list-style-type: none"> • Mile Post (MP) 5.04 (Wayne Avenue), Built 1893 • MP 5.72 (Logan Street), Built 1932 • MP 7.63 (Chew Street), Built 1901 • MP 8.90 (Mt. Pleasant Avenue), Built 1907 • MP 9.59 (Cresheim Valley Drive), Built 1931 	\$30.00 M	Design and Construction 2023 - 2028	Philadelphia	Philadelphia
Chestnut Hill West Line Bridge Rehabilitation Program				
Rehabilitation of seven bridges on the Chestnut Hill West Regional Rail Line located at: <ul style="list-style-type: none"> • MP 0.06 (SEPTA Main Line), Built 1913 • MP 0.83 (22nd Street), Built 1918 • MP 1.17 (Hunting Park Avenue), Built 1910 • MP 1.26 (CSX Tracks), Built 1917 • MP 2.98 (Rittenhouse Street), Built 1918 • MP 4.42 (Carpenter Lane), Built 1928 • MP 5.67 (Springfield Avenue), Built 1917 	\$35.00 M	Design and Construction 2023 - 2028	Philadelphia	Philadelphia

BRIDGE PROGRAM

Project Descriptions	Budget	Schedule / Status (Calendar Year)	Location	Service Area
Critical Bridge Program				
<p>Annual program to rehabilitate or replace bridges throughout the system to restore infrastructure to a state of good repair.</p> <p>Bridges programmed for design and/or construction in FY 2024 include but are not limited to:</p> <ul style="list-style-type: none"> • Fox Chase Line MP 7.03 (3rd St. Philadelphia), Built 1910 • Lansdale/Doylestown Line MP 11.62 (Keswick Ave.), Built 1904 • Lansdale/Doylestown Line MP 11.83 (Easton Road), Built 1928 • Media/Elwyn Line MP 10.12 (Small Run), Built 1965 • Media/Elwyn Line MP 13.81 (Park Ave.), Built 1917 • Manayunk/Norristown Line MP 17.16 (Dekalb St.), Built 1931 • Manayunk/Norristown Line MP 17.77 (Stoney Creek), Built 1900 • West Trenton Line MP 31.63 (Delaware & Raritan Canal), Built 1902 	\$172.84 M	Ongoing	Bucks Chester Delaware Montgomery Philadelphia	System-Wide
Mainline–Schuylkill Bridges (30th Street Station to Suburban Station)				
<p>Rehabilitation of seven bridges between 30th Street Station and Suburban Station located at: MP 0.49 (21st Street); MP 0.58 (22nd Street); MPs 0.61, 0.64 and 0.68 (22nd Street/23rd Street); MP 0.72 (CSX Tracks); and MP 0.76 (Schuylkill River). These bridges were built in 1929.</p> <p>The first phase of this project included critical repairs to bridges MP 0.49 and MP 0.58. The second phase will include duct bank and cable work. The third phase will include complete rehabilitation of all seven bridges.</p>	<p>Phase 2 \$10.95 M</p> <p>Phase 3 \$45.05 M</p>	<p>Phase 1 – Complete</p> <p>Phase 2 Design & Construction 2021 – 2025</p> <p>Phase 3 Design 2023 - 2025 Construction 2029 – 2032</p>	Philadelphia	System-Wide

Project Descriptions	Budget	Schedule / Status (Calendar Year)	Location	Service Area
Stone Arch Bridge Program - Phase 2				
Rehabilitation of Stone Arch Bridges on the Regional Railroad, including: Phase 2A (in Construction) <ul style="list-style-type: none"> • Lansdale/Doylestown Line MP 18.91 (Stream), Built 1903 • West Trenton Line MP 13.70 (Stream), Built 1912 • West Trenton Line MP 15.95 (Stream), Built 1876 • West Trenton Line MP 18.52 (Stream), Built 1948 Phase 2B (in Design/Construction) <ul style="list-style-type: none"> • Lansdale/Doylestown Line MP 4.87 (Creek), Built 1915 • Lansdale/Doylestown Line MP 17.31 (Honey Run Creek), Built 1903 • West Trenton Line MP 14.20 (Stream), Built 1912 	\$13.20 M	Construction 2020 – 2025	Bucks Delaware Montgomery Philadelphia	System-Wide
Transit Bridge Projects (FY 2024 – 2028)				
NHSL Bridge 0.15 over 69th St. Yard Tracks				
Critical repairs to the superstructure of Bridge 0.15 on the Norristown High Speed Line (NHSL). This bridge was built in 1906. Construction is being advanced in phases to limit operational impacts.	\$4.00 M	Construction 2018 – 2024	Delaware	Delaware Montgomery
NHSL Viaduct over Schuylkill River				
Rehabilitation of the Bridgeport Viaduct at Mile Post 12.81 (Schuylkill River) on the NHSL. The project includes steel, concrete and bearing repairs and painting. The viaduct was constructed in 1911 and is 3,165 feet long.	\$35.00 M	Design 2022-2024 Construction 2024 - 2027	Montgomery	Delaware Montgomery

COMMUNICATIONS, SIGNAL SYSTEMS AND TECHNOLOGY IMPROVEMENTS

This program provides for improvements to SEPTA’s communications systems, signal systems, and information technology infrastructure - including vehicle and facility video systems. As part of its capital program, SEPTA will replace its Computer Aided Radio Dispatch (CARD) System, install Positive Train Control on the Route 101/102 Trolley lines [Media-Sharon Hill Line (MSHL)], upgrade dispatching and scheduling systems, and implement a real-time vehicle arrival information display system. Rail signal modernization projects and interlocking improvements will enhance operational reliability and service quality. The annual Information Technology program provides replacement and upgrades of the Authority’s computer hardware, software and network equipment, such as servers, digital signage, and Enterprise applications. This program also provides capital dollars to support SEPTA’s transformative Efficiency and Accountability Initiative to improve how SEPTA functions as an organization on a day-to-day basis.

Communications, Signal Systems and Technology Improvements - Program Elements (\$ Millions)	Prior Funding	FY 2024	FY 2025	FY 2026	FY 2027	FY 2028	FY 2029 - 2035	12-Year Program Total	Total Budget
Communications & Signals	\$397.12	\$66.64	\$72.86	\$52.13	\$63.32	\$61.98	\$300.77	\$617.70	\$1,014.83
Technology Improvements	\$150.50	\$33.59	\$32.33	\$29.10	\$27.63	\$26.69	\$160.38	\$309.72	\$360.21
Communications, Signal Systems and Technology Improvements Total	\$447.62	\$100.23	\$105.19	\$81.23	\$90.95	\$88.67	\$461.15	\$927.42	\$1,375.04



101/102 Positive Train Control and Right-of-Way Improvements



Southwest Connection Improvement Program

COMMUNICATIONS, SIGNAL SYSTEMS AND TECHNOLOGY IMPROVEMENTS

Project Descriptions	Budget	Schedule / Status (Calendar Year)	Location	Service Area
Communications & Signal Improvements - Railroad Projects (FY 2024 – 2035)				
Harrisburg Line Capacity Improvements: Bidirectional Signaling - Paoli to Overbrook				
<p>This Federal Railroad Administration (FRA) Federal-State Partnership Grant Program funded project will bring the Paoli/Thorndale Line signal system to a state of good repair. The project will replace existing signal infrastructure with a modern bidirectional signal system that requires less maintenance and is more resistant to disruptions. Upgrading all tracks with bidirectional signals will greatly improve operational flexibility, reduce congestion, and add resiliency. This project is a joint effort of SEPTA, Amtrak, and the Pennsylvania Department of Transportation (PennDOT).</p>	\$21.91 M	Design & Construction 2022 - 2028	Chester Montgomery Philadelphia	System-wide
Positive Train Control				
<p>Design and installation of a Positive Train Control (PTC) system for the Railroad Division. The PTC system is similar in all aspects to the system provided on the Northeast Corridor, to ensure complete interoperability not only with Amtrak, but with the various freight carriers that operate in SEPTA’s territory. SEPTA has implemented PTC systems on all Regional Rail lines. The remaining work involves the cohesive integration and interoperability of SEPTA’s PTC system with CSX and Norfolk Southern PTC systems throughout the region. Construction was completed in 2021.</p>	\$174.02 M	Continuing Integration with Partner Railroads 2021 - 2026	Bucks Chester Delaware Montgomery Philadelphia Delaware (State) New Jersey	System-wide

COMMUNICATIONS, SIGNAL SYSTEMS AND TECHNOLOGY IMPROVEMENTS

Project Descriptions	Budget	Schedule / Status (Calendar Year)	Location	Service Area
<p>Positive Train Control - Onboard Survey Mapping</p> <p>Development of a Positive Train Control (PTC) Onboard Survey Map Software as required by the Federal Railroad Administration (FRA). The project will enhance SEPTA's existing PTC system (ACSEC II) by providing a supplementary and redundant safety measure. An Onboard Survey Map will contain the physical characteristics of the railroad that informs the train of the speeds and restrictions associated with its location. The information on the survey map is the same as the existing transponders but will be housed in the train's onboard computer. Having both a wayside and vehicle notification will strengthen SEPTA's PTC system and will comply with FRA requirements. This is the first phase of the project.</p>	\$3.30 M	Development 2021 - 2025	Bucks Chester Delaware Montgomery Philadelphia Delaware (State) New Jersey	System-wide
<p>Railroad Interlocking Improvement Program</p> <p>Rebuilding, reconfiguration and construction of railroad interlockings to improve operational efficiency. Regional Rail locations include but are not limited to 16th Street Interlocking, 20th Street Interlocking, Beth and York Interlockings, Broad Interlocking, Hunt Interlocking, Wayne Interlocking, and Schuylkill Interlocking.</p>	\$214.02 M	Ongoing	Montgomery Philadelphia	System-wide
<p>Southwest Connection Improvement Program (SCIP)</p> <p>Reconfiguration and rebuilding of signals, track, catenary, and interlockings from 30th Street Station to Phil Interlocking. Work includes new track special work, overhead contact systems (OCS), and updated signal system, as well as the addition of new PTC systems.</p>	\$57.99 M	Construction 2017 - 2024	Philadelphia	System-wide

COMMUNICATIONS, SIGNAL SYSTEMS AND TECHNOLOGY IMPROVEMENTS

Project Descriptions	Budget	Schedule / Status (Calendar Year)	Location	Service Area
Communications & Signal Improvements - Railroad Projects (FY 2029 – 2035)				
Regional Railroad Signal Improvement Program				
Modernization of the signal system on the Regional Rail Network. Work will include upgrades to improve operational reliability for the train control systems on the entire Regional Rail network.	\$40.00 M	Implementation 2029 - 2035	System-wide	System-wide
Communications & Signal Improvements - Transit Projects (FY 2024 – 2035)				
Broad Street Subway Line Signals				
Modernization of the signal system on the Broad Street Line and Broad-Ridge Spur. Work includes upgrades to improve operational reliability for the train control systems on the entire corridor.	Broad-Ridge Spur \$14.66 M	Design & Construction 2015 - 2024	Philadelphia	Philadelphia
	Broad Street Subway \$65.00 M	Design & Construction 2029 - 2035		
Norristown High Speed Line Interlockings				
Renewal and reconfiguration of interlockings on the Norristown High Speed Line at County Line Siding, Wynnewood, Bryn Mawr, and Matsonford to bring interlockings to a state of good repair and improve operational reliability.	\$12.27 M	Design & Construction 2018 - 2024	Delaware Montgomery	Delaware Montgomery

COMMUNICATIONS, SIGNAL SYSTEMS AND TECHNOLOGY IMPROVEMENTS

Project Descriptions	Budget	Schedule / Status (Calendar Year)	Location	Service Area
Route 101/102 Positive Train Control and ROW Improvements				
Installation of a new state-of-the art Communications Based Train Control (CBTC) system for the Route 101/102 trolley lines. The new system will automatically enforce trolley separation and provide overspeed and roadway worker protection. New power switching will be installed to facilitate operational flexibility. Includes new interlockings, track special work and power work, as well as a new Remote Operations Control Center.	\$95.00 M	Construction 2015 - 2024	Delaware	Delaware
Signal System Renewal on the Norristown High Speed Line				
Modernization of the signal system on the Norristown High Speed Line (NHSL). Work includes upgrades to improve operational reliability for the train control systems on the entire corridor. This project will address state of good repair needs for the existing line while ensuring resiliency by including the latest technology enhancements for signal systems.	\$80.00 M	Design 2023 - 2025	Delaware Montgomery	Delaware Montgomery
		Construction 2026 - 2030		

COMMUNICATIONS, SIGNAL SYSTEMS AND TECHNOLOGY IMPROVEMENTS

Project Descriptions	Budget	Schedule / Status (Calendar Year)	Location	Service Area
Communications & Signal Improvements – System-Wide Projects (FY 2024 – 2029)				

Computer Aided Radio Dispatch (CARD) System Replacement

This project will retire the existing Computer Aided Radio Dispatch (CARD) system. The CARD system is made up of two main subsystems: the Radio System and the Computer-Aided Dispatch / Automatic Vehicle Location system (CAD/AVL). Both systems are at end of system design lifespan. The current 502MHz radio system (T-Band) will be replaced with a new state-of-the-art 700 MHz radio system covering transit operations in the five counties in which SEPTA operates. The Transit Police were previously added to the system that includes interoperability with partner agencies in the City of Philadelphia and surrounding counties.

\$124.82 M

Construction
2022 – 2028

Bucks
Chester
Delaware
Montgomery
Philadelphia

System-wide

The CARD system is used to dispatch SEPTA buses, trolleys, Norristown High Speed Line, and paratransit vehicles and is the system that bus, and trolley operators use to communicate with the control center. The new system will provide enhanced functionality to improve SEPTA transit operations including real-time vehicle arrival information to be displayed on existing and new Audio-Visual Public Address (AVPA) signs, as well as the SEPTA website. Design is complete.

COMMUNICATIONS, SIGNAL SYSTEMS AND TECHNOLOGY IMPROVEMENTS

Project Descriptions	Budget	Schedule / Status (Calendar Year)	Location	Service Area
<p>Regional Rail VHF Radio Upgrade</p> <p>SEPTA operates a VHF conventional simulcast radio system compliance with AREMA and AAR standards to support Regional Railroad Operations on both SEPTA and Amtrak. The equipment utilized has reached the end of its useful life, in addition the original radio coverage design is 40+ years old and was maximized for mobile radio vehicle coverage not portable radio coverage. As a result, existing talk-out and talk-back coverage gaps are present with portable talk-back coverage deficiencies which pose potential safety hazards. The five channels in use are called North Road, South Road, Center City, Station and Maintenance of Way.</p>	\$57.00 M	Design and Construction 2024 - 2029	System-wide	System-wide
<p>Control Center Wall Display</p> <p>This project will provide for replacement of display hardware and technology upgrades for the Control Center and Video Evidence Department. The Control Center video walls are essential to the safe and efficient operation of all SEPTA modes of transportation. The current software and equipment are past their useful life. Design is complete.</p>	\$6.39 M	Construction 2021 - 2024	Philadelphia	System-wide

COMMUNICATIONS, SIGNAL SYSTEMS AND TECHNOLOGY IMPROVEMENTS

Project Descriptions	Budget	Schedule / Status (Calendar Year)	Location	Service Area
Real-Time Information / Audio Visual Public Address (AVPA) System				
Upgrade and modernization of SEPTA’s real-time arrival information for customers on all SEPTA modes of transportation. Includes installation of a Real-Time Vehicle Locating system on all SEPTA vehicles, providing vehicle location information that will be accessible to the public via smartphone applications and the web. In addition, SEPTA will upgrade Audio Visual Public Address (AVPA) equipment at all railroad and transit stations.	\$34.73 M	Implementation 2017 - 2026	System-wide	System-wide
Telecommunications System Replacement				
This project will replace SEPTA’s current telecommunications services with a new Voice over IP (VoIP) system. The resulting network will provide a secure, cost-effective, and high-reliability infrastructure for the voice systems. It will utilize existing internal cables and provides a method for integration into existing third-party systems, such as those used in the Control Center and Customer Call Centers. The project will also deliver additional benefits, including the option to migrate other services currently operating on the legacy phone system currently used at rail transit stations.	\$13.71 M	Design & Implementation 2022 - 2025	System-wide	System-wide

COMMUNICATIONS, SIGNAL SYSTEMS AND TECHNOLOGY IMPROVEMENTS

Project Descriptions	Budget	Schedule / Status (Calendar Year)	Location	Service Area
Technology Improvements (FY 2024 – 2025)				
Key System Network Communications Hardware				
Key system network communications hardware includes modems, antennas, station-level network switches and communication room UPS units. The existing communications network devices are at the end of their useful life and approaching their end-of-support dates.	\$6.00 M	Design & Construction 2023 - 2025	System-wide	System-wide
Fare Box Replacement				
This project is for the replacement of 1,500 fareboxes, spare parts, test equipment and a tracking system for repairs and replacements. The current fareboxes are beyond their useful life.	\$22.00 M	Design & Construction 2023 – 2025	System-wide	System-wide
Zero Eyes				
This project is to install ZeroEyes weapon detection technology on 3,000 security cameras to help prevent gun violence and aid prosecution of firearms offenses.	\$2.50 M	Implementation 2023 – 2025	System-wide	System-wide
Fare Evasion Pilot Program				
This project will test new fare gate technology to deter and reduce fare evasion.	\$0.99 M	Design & Construction 2023 – 2024	Philadelphia	Philadelphia

COMMUNICATIONS, SIGNAL SYSTEMS AND TECHNOLOGY IMPROVEMENTS

Project Descriptions	Budget	Schedule / Status (Calendar Year)	Location	Service Area
<p>Information Technology Program</p> <p>SEPTA addresses technology as 21st Century infrastructure. This program provides for the upgrades of back-end infrastructure systems to implement industry best practices in communications and control systems, as well as improved digital services for customers. SEPTA’s IT upgrades and improvements include new and replacement computer hardware and software, Enterprise Resource Systems (ERP), threat detection security appliances, and real-time location information for SEPTA travel and fare collection. Additionally, SEPTA will begin capitalizing acquisition, integration, and upgrade costs associated with cloud-based technology assets in accordance with Governmental Accounting Standards Board (GASB) guidance.</p> <p>The FY 2024 program includes:</p> <ul style="list-style-type: none"> • An initiative to upgrade Enterprise applications, including a replacement of the Financial, Human Resources, Payroll and Benefits systems; • Security and Network Appliance Technology Refresh including Cyber Security Appliances and related Hardware/Software; • Technology Program computers, laptops, and mobile devices; • Operations Applications and VMIS Upgrade/Replacement; • Public Facing Systems Refresh/Upgrade such as Web Services, Mobile Applications, Trip Planner. This includes investing in real-time data information for all modes of SEPTA transportation including applications for display signs, website and mobile app, and Application Programming Interface (APIs) for open data initiatives; • Enhancements to SEPTA’s network infrastructure including secure wireless networking for internal business and operational purposes; • Operational Technology (OT) Cyber Security Initiatives. 	\$267.08 M	Ongoing	Philadelphia	System-wide

COMMUNICATIONS, SIGNAL SYSTEMS AND TECHNOLOGY IMPROVEMENTS

Project Descriptions	Budget	Schedule / Status (Calendar Year)	Location	Service Area
SEPTA Transformation - Efficiency and Accountability Capital Support				
<p>This program will provide capital funding to support SEPTA’s Efficiency and Accountability (E&A) Transformation program. Spearheaded by a newly established Transformation Office, the SEPTA E&A initiative is an effort taking place across SEPTA which gives the Authority a framework to look within the organization and operations to understand where it can be better for employees and riders. This initiative has four main goals:</p> <ul style="list-style-type: none"> - Ensuring SEPTA has the right capabilities, mindsets, and resources in place to deliver on our strategic plan - Eliminating day-to-day pain points to make SEPTA a more satisfying place to work for employees - Driving efficiency, productivity, and accountability improvements in business units across the organization - Pursuing cost-saving and revenue-generating opportunities that put SEPTA on firm financial footing <p>Efforts being funded by this project include installation of communications video and training screens at SEPTA facilities, installation of self-compacting trash receptacles at rail stations, deployment of tablets at back shops, and other capital investments necessary to support SEPTA’s transformation efforts.</p>	\$2.50 M	Design & Implementation 2022 - 2024	System-wide	System-wide
Transit Asset Management System				
<p>The project includes the development and implementation of a system-wide asset management program that will automate the process of managing all assets and provide real-time inventory control. The system will have the data necessary to accurately track existing inventory and conditions.</p>	\$6.77 M	Design & Implementation 2011 – 2024	Philadelphia	System-wide

COMMUNICATIONS, SIGNAL SYSTEMS AND TECHNOLOGY IMPROVEMENTS

Project Descriptions	Budget	Schedule / Status (Calendar Year)	Location	Service Area
Video Systems Refreshment Program Replacement of existing Mobile Video System components and installation of equipment on SEPTA's vehicle fleets including, but not limited to inward facing cameras within Regional Rail Cars and crash hardened digital video recording devices in the bus fleet.	\$42.37 M	Ongoing	System-wide	System-wide

FINANCIAL OBLIGATIONS

The Capital Asset Lease Program provides for payments attributable to capital leases. Capital Asset Leases covered by this program include Amtrak trackage leases, copier machines throughout the Authority, and communications towers.

State and federal capital funds provide for debt service and the cost of issuance of bonds, notes and other indebtedness incurred by SEPTA. In addition to the three series of bonds previously issued, in October 2022 SEPTA issued bonds in the amount of \$550 million to pay for critical state of good repair and ADA Accessibility projects over the next several fiscal years. Additional bond issuances to cover short and long-term capital needs will continue to be explored.



SEPTA Operation on Amtrak's Keystone Corridor

Financial Obligations - Program Elements (\$ Millions)	Prior Funding	FY 2024*	FY 2025*	FY 2026*	FY 2027	FY 2028	FY 2029 - 2035	12-Year Program Total	Total Budget
Capital Leases	\$90.00	\$30.16	\$37.40	\$39.45	\$71.56	\$73.72	\$574.32	\$826.61	\$916.61
Debt Service	\$0.00	\$74.54	\$74.54	\$74.54	\$99.45	\$126.86	\$1,076.31	\$1,526.25	\$1,526.25
Financial Obligations Total	\$90.00	\$104.71	\$111.94	\$113.99	\$171.01	\$200.58	\$1,650.63	\$2,352.86	\$2,442.86

* FY 2024, FY 2025 and FY 2026 Capital Leases budgets reflect fiscal year allocations. Forecasted Capital Lease payments for FY 2024 are \$60.16M supported by prior year funding of \$30M; FY 2025 forecasted payments are \$67.40M supported by prior year funding of \$30.00M; and FY 2026 forecasted payments are \$69.45M supported by prior year funding of \$30M.



Wayne Junction Station (Series 2017/2019 Bond)



Frazer Shop and Yard / Regional Rail Electric Locomotive

Project Descriptions	Budget	Schedule / Status (Calendar Year)	Location	Service Area
Capital Asset Leases (FY 2024 – 2035)				
Amtrak Trackage				
<p>This agreement provides a payment mechanism for SEPTA’s use of Amtrak tracks to operate the Trenton, Wilmington/Newark and Paoli/Thorndale Regional Rail service, and portions of the Chestnut Hill West, Airport and Cynwyd Regional Rail Lines. With the enactment of the Passenger Rail Investment and Improvement Act of 2008 (PRIIA), Congress mandated that a standardized methodology be developed to allocate costs among the Northeast Corridor (NEC) owners and operators that ensures each agency take the full financial responsibility for its use of shared NEC infrastructure and related facilities. Payments made to Amtrak under this agreement are SEPTA’s costs based on methodologies and policies established by the NEC Infrastructure and Operations Advisory Commission for all NEC users pursuant to PRIIA.</p>	<p>12-Year Total \$826.61 M</p>	<p>Ongoing</p>	<p>System-wide</p>	<p>System-wide</p>
Copiers				
<p>This lease provides for rental of copiers, which are dispersed throughout SEPTA’s headquarters and transportation/maintenance facilities.</p>	<p>12-Year Total \$4.95 M</p>	<p>Ongoing</p>	<p>System-wide</p>	<p>System-wide</p>
Communications Towers				
<p>This lease provides for the right to house voice and data transmission and receiving equipment on towers at the following locations: Y-100, Loews Hotel, Malvern, West Rockhill, Lincoln Plaza Center, Newtown Square, and New Britain.</p>	<p>12-Year Total \$11.43 M</p>	<p>Ongoing</p>	<p>System-wide</p>	<p>System-wide</p>

FINANCIAL OBLIGATIONS

Project Descriptions	Budget	Schedule / Status (Calendar Year)	Location	Service Area
Debt Service (FY 2024 – 2035)				
Payments on Capital Grant Receipts Bonds, Series 2011/2017				
<p>Acquisition of 120 Silverliner V Regional Rail Cars - These electric multiple-unit (EMU) cars have replaced the Silverliner II and III rail cars, and provided additional cars to supplement the regional rail car fleet. Vehicles fully comply with Americans with Disabilities Act (ADA) requirements and federal and state regulations. The total cost for this project of \$319.7 million is funded through a combination of grants and capital financing.</p>	<p>12-Year Debt Service Total</p> <p>\$92.81 M</p>	<p>Final year of debt service funding for Series 2011/2017 Bonds - 2029</p>	<p>System-wide</p>	<p>System-wide</p>
<p>Rehabilitation of the Wayne Junction Intermodal Facility - The Wayne Junction Intermodal Facility was originally constructed at the turn of the 20th Century. This project provided for restoring the station’s historic integrity while modernizing its structure to provide a more accessible and environmentally friendly facility for local residents. The project provided for the enhancement of passenger amenities such as lighting, signage, shelters, audio and visual public announcement system, windscreens, benches, HVAC systems, and sanitary systems. Structural improvements included station building rehabilitation and ADA accessibility modifications, such as high-level platforms, elevators, stairway renovations, passenger tunnel improvements, new canopies and shelters. The total project cost of \$29.4 million is funded through a Federal Transit Administration Bus and Bus Facilities Livability Grant and capital financing.</p>				
<p>In October 2017, the Authority advance refunded a portion of Capital Grant Receipts Bonds, Series 2011 (“Series 2011 Bonds”), to reduce future debt service payments. The final maturity date of the newly issued Series 2017 Bonds was unchanged from the Series 2011 Bonds.</p>				

Project Descriptions	Budget	Schedule / Status (Calendar Year)	Location	Service Area
Payments on Fixed Rate Revenue Refunding Bonds, Series 2017/2019				
<p>Proceeds from the Fixed Rate Revenue Refunding Bonds (“Series 2010 Bonds”) were used to refund the Special Revenue Bonds, Series 1999, which provided funds for the Market-Frankford Line cars, various capital improvement projects, and partial refunding of Series 1995A Bonds. In October 2017, the Authority advance refunded a portion of the Series 2010 Bonds to reduce future debt service payments. In December 2019, the Authority refunded a portion of the Series 2010 bonds to further reduce future debt service payments. The final maturity of the Series 2017 and 2019 bonds was unchanged from the Series 2010 bonds.</p>	<p>12-Year Debt Service Total \$59.40 M</p>	<p>Final year of debt service funding for Series 2017/2019 Bonds - 2028</p>	<p>System-wide</p>	<p>System-wide</p>
Payments on Capital Grant Receipts Bonds, Series 2020				
<p>Acquisition of 140 Hybrid (Diesel-Electric) Buses – These buses replaced diesel buses acquired in 2004. The vehicles fully comply with Americans with Disabilities Act (ADA) requirements and federal and state regulations. The buses have electronic exterior and interior destination signs, voice announcement of bus destination and upcoming bus stops, interior video display monitors and the capability for SEPTA’s Control Center to broadcast messages directly to passengers. These buses are equipped with on-board video surveillance and automatic passenger counting systems. The buses are also equipped with enhanced passenger amenities such as USB Charging Ports, Cellular Router for real time critical vehicle data on demand and a dual-purpose Passenger Wi-fi system, and a QPod Wheelchair Restraint System to decrease wheelchair and scooter ambulatory device tipping.</p>	<p>12-Year Debt Service Total \$98.83 M</p>	<p>Final year of debt service funding for other Capital Financing - 2032</p>	<p>System-wide</p>	<p>System-wide</p>

FINANCIAL OBLIGATIONS

Project Descriptions	Budget	Schedule / Status (Calendar Year)	Location	Service Area
<p>Payments on State Motor Vehicle Sales Tax Bonds, Series 2022</p> <p>In October 2022, SEPTA issued bonds in the amount of \$550 M to support SEPTA’s capital program. This approval is based on PennDOT’s prior approval for SEPTA to issue debt pursuant to Section 1514(f) of Title 74 of the Pennsylvania Consolidated Statutes. The funds will be utilized for the refinancing of SEPTA’s outstanding EB-5 Loan as well as various state of good repair infrastructure, ADA Accessibility station, and rail fleet replacement projects.</p>	<p>12-year Debt Service Total (Estimated) \$1,275.21 M</p>	<p>Final year of debt service funding for other Capital Financing (Estimated) – 2052</p>	<p>System-wide</p>	<p>System-wide</p>

INFRASTRUCTURE SAFETY RENEWAL PROGRAM (ISRP)

The annual Infrastructure Safety Renewal Program (ISRP) provides for the restoration by SEPTA forces of SEPTA's City and Suburban transit and railroad infrastructure to a state of good repair. Projects to be advanced include:

- **Track and Right-of-Way** - Renewal or replacement of track, switches, and special work including yard and shop areas, track surfacing, culverts, bridges, retaining wall, and grade crossing improvements.
- **Station Facilities** - Rehabilitation and ADA Accessibility improvements of station buildings and associated facilities, including roofs and canopies, ticket offices and waiting rooms, platforms, lighting, sanitary facilities, and parking.
- **Communications and Signals Systems** - Rehabilitation of signal systems and select communications equipment.
- **Power Systems** - Rehabilitation of electric traction and power systems and associated components including catenary and support structures, feeders and transmission lines, and localized and centralized control facilities.
- **Maintenance/Support Facilities** - Rehabilitation of shops, maintenance/storage yards, and associated maintenance and support facilities, including improvements or replacement of air compressors, sump pumps, tunnel lighting, duct banks, vehicle servicing equipment, and other support functions.

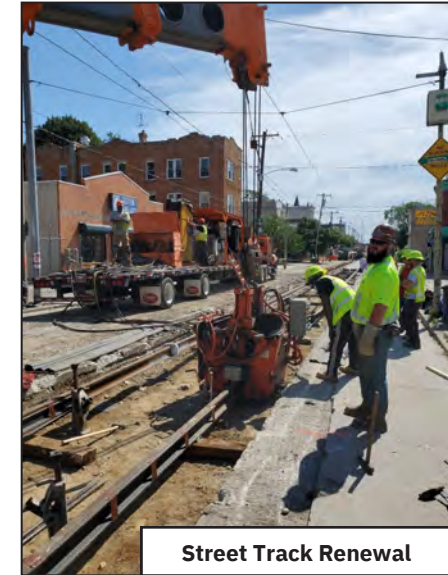

Street Track Renewal

Infrastructure Safety Renewal Program (ISRP) - Program Elements (\$ Millions)	Prior Funding	FY 2024	FY 2025	FY 2026	FY 2027	FY 2028	FY 2029 - 2035	12-Year Program Total	Total Budget
ISRP	\$0.00	\$60.46	\$61.67	\$62.91	\$64.16	\$65.44	\$496.26	\$810.90	\$810.90
ISRP Total	\$0.00	\$60.46	\$61.67	\$62.91	\$64.16	\$65.44	\$496.26	\$810.90	\$810.90



Power Systems



Track and Right-of-Way

INFRASTRUCTURE SAFETY RENEWAL PROGRAM (ISRP)

Project Descriptions	Budget	Schedule / Status (Calendar Year)	Location	Service Area
Fiscal Year 2024 ISRP Program	\$810.9M	2024 - 2035	System-wide	System-wide
<p><i>Track and Right-of-Way Program</i> <u>Regional Rail</u> - Regional Rail (RRD) Tie, Surface, and Brush Cutting Program; RRD Open Deck Bridge Timber Renewal; Track Bumper Replacement Program; West Trenton (Neshaminy) Continuous Welded Rail (CWR); Railroad Curve Worn Rail. <u>City/Suburban Transit</u> - City/Suburban Transit High Speed Special Track Work Renewal; Trolley Track Renewal Program; Market-Frankford Line (MFL) Direct Fixation Fastener Replacement; Track Bumper Replacement Program; STD Grade Crossing Renewal; Embedded Special Work; MSHL Tie Renewal.</p>				<p><i>Communications and Signals Program</i> <u>Regional Rail</u> - Communications & Signals Cable Installation Program; Pedestrian Crossings Program; Crossing Flasher Upgrades. <u>City/Suburban Transit</u> - Erie Interlocking Microprocessor Tech Refresh Project; Green Line Communications Based Train Control (CBTC) Upgrade; Market-Frankford Line Switch Machine Replacement; Market-Frankford Line Tech Refresh; Train Stop Replacement; PD-1 Relay Replacement. <u>Regional Rail / City/Suburban Transit</u> - Communications & Signals Standards Renewal Project Phase 2; Distributed Communications System (DCS) Project Phase 2; Security Camera Program.</p>
<p><i>Station Facilities Program</i> <u>Regional Rail</u> - Platform Improvements Program; Paoli Line Station Improvements Program; Pedestrian Tunnel Improvement Program; Center City RRD Stations Security Improvements; Station Improvements Program; Wallingford Platform Extension; Center City Dewatering Pump Upgrades. <u>City/Suburban Transit</u> - Station Entrance Improvements; Norristown High Speed Line (NHSL) Station Improvements; MFL Station Renewal Program; 69th Street Master Plan; 33rd & Dickenson Loop Improvement; Media-Sharon Hill Line (MSHL) Platform Improvements; Broad Street Subway (BSS) Station Renewal Program.</p>				<p><i>Power Systems Program</i> <u>Regional Rail</u> - Substation Control Battery Replacement RRD; Sectionalizing Switch/Remote Terminal Unit (RTU)/Section Insulators (SI) Replacement Program; Feeder and Signal Component Replacement; Negative Return System Improvement Program; Fox Chase Line Catenary Replacement; Wire Train Platform Replacement; Third Feeder Installation - Wayne Junction to Jenkintown; Airport Line Overhead Catenary System (OCS) Replacement Design. <u>City/Suburban Transit</u> - Manhole Rehabilitation Program; AC Power & Lighting Cable Replacement Program; City/Suburban Transit Substation Improvement Program; Trackless Trolley Power System Upgrade Program; 4/0 Trolley Wire Replacement Program; Suburban Transit LED Lighting Upgrade Program; Stinger System Replacement at Bridge Street Carhouse.</p>
<p><i>Maintenance/Support Facilities Program</i> <u>Regional Rail</u> - RRD Vent Well Reconstruction; Critical Catenary Structural Rehabilitation Program; Facilities Improvement Program (F.I.T.); Compressor House Upgrades. <u>City/Suburban Transit</u> - Vent Well and Emergency Exit Rehabilitation; Pump Room Overhaul Program; Facilities Improvement Team (F.I.T.); Garage and Shop Improvement Program; Ejector Room Replacement Program; Subway Column Rehab; V-Tag Wayside and Control System Upgrade; Motor Generator Improvement Program.</p>				<p><i>Civil Infrastructure Program</i> <u>Regional Rail</u> - Dynamic Envelope Striping and Delineators; Culvert Improvement Project <u>City/Suburban Transit</u> - Route 1 Pullover Improvements; Victory Crossing.</p>

MAINTENANCE/TRANSPORTATION SHOPS AND OFFICES

This program provides for improvements to SEPTA's bus and rail maintenance shops, administrative facilities, and office buildings. This program includes ongoing renewal and replacement of programs including but not limited to the wheel truing, bus and steel wheel lift, fire suppression, boilers, vehicle washer, shop and yard upgrades, and paving improvements. In addition, this program includes new facilities and rehabilitation of existing facilities as well as a roof rehabilitation and replacement program. Remediation and clean up activities at select facilities as well as activities that will reduce SEPTA's carbon footprint and enhance SEPTA's commitment to sustainability are also included in this program.



Maintenance Shop Equipment—Fall Arrest System

Maintenance/Transportation Shops and Offices - Program Elements (\$ Millions)	Prior Funding	FY 2024	FY 2025	FY 2026	FY 2027	FY 2028	FY 2029 - 2035	12-Year Program Total	Total Budget
Maintenance/Transportation Facilities and Offices	\$155.65	\$72.30	\$64.95	\$41.17	\$31.64	\$29.90	\$154.79	\$394.74	\$550.39
Roof Program	\$46.00	\$5.22	\$9.86	\$12.22	\$4.22	\$3.22	\$16.31	\$51.05	\$97.05
Maintenance/Transportation Shops and Offices Total	\$201.64	\$77.51	\$74.81	\$53.39	\$35.86	\$33.13	\$171.10	\$445.79	\$647.44



Frazer Rail Shop and Yard Upgrade



Courtland Shop Improvements

MAINTENANCE/TRANSPORTATION SHOPS AND OFFICES

Project Descriptions	Budget	Schedule / Status (Calendar Year)	Location	Service Area
Maintenance & Transportation Facilities (FY 2024 – 2035)				
Boiler Replacement Program				
Replacement of boilers at various SEPTA facilities. The boilers have exceeded their useful life and will be replaced with new energy efficient boilers.	\$5.65 M	Design & Construction 2024 - 2035	Delaware Montgomery Philadelphia	System-wide
Bus Lift Program				
Replacement of in-ground and portable lifts that have exceeded their useful life at select SEPTA City Transit and Suburban Transit bus maintenance facilities.	\$5.65 M	Design & Construction 2024 - 2035	Delaware Montgomery Philadelphia	System-wide
Courtland Shop Improvements				
Address the conditions at SEPTA's Courtland Track and Carpentry Facility. The design phase will evaluate renovation of the existing facility and relocating SEPTA crews to new facilities.	\$22.50 M	Design 2018 - 2023	Philadelphia	System-wide
		Construction 2024 - 2026		
Environmental Clean Up and Protection				
Activities include remediation associated with underground storage tanks, lead-based paint, asbestos, contaminated soil and groundwater. Site assessments to determine environmental exposure prior to acquiring properties are included under this program. The program also includes activities that will reduce SEPTA's environmental footprint, such as recycling containers and trash compactors.	\$15.27 M	Ongoing	Bucks Chester Delaware Montgomery Philadelphia	System-wide

MAINTENANCE/TRANSPORTATION SHOPS AND OFFICES

Project Descriptions	Budget	Schedule / Status (Calendar Year)	Location	Service Area
<p>Facilities Critical Infrastructure Program</p> <p>Annual renovation, renewal, and acquisition of critical infrastructure for SEPTA facilities including, but not limited to buildings, heating, ventilation, air conditioning, plumbing, and lighting. This is an ongoing systemwide program to address critical needs to keep the SEPTA system operating reliably and safely.</p>	\$62.30 M	Ongoing	Bucks Chester Delaware Montgomery Philadelphia	System-wide
<p>Facilities Furnishings Program</p> <p>This program will replace various facility furnishings throughout the Authority. Replacements will include Bus and Rail Operations facility furniture along with 1234 Market Street cubicle and office furniture. This program also includes planning and implementing a tracking and inventory program for Authority furnishings.</p>	\$7.00 M	Ongoing	System-wide	System-wide
<p>Frazer Rail Shop and Yard Expansion</p> <p>Phased upgrade of the Frazer Maintenance Facility to accommodate the expansion of SEPTA's Regional Rail railcar and locomotive fleets including multi-level railcars. Work includes extending existing storage tracks and adding new storage tracks; major upgrades to the repair shop and equipment, including the wheel truing machine and drop table; construction of a shop extension, new cleaning track, train washer building, storage building and yardmaster building; utility upgrades and stormwater improvements. In addition, the roof and mechanical equipment will be replaced.</p>	\$139.00 M	Phase 3: Construction 2022 – 2025	Chester	System-wide

MAINTENANCE/TRANSPORTATION SHOPS AND OFFICES

Project Descriptions	Budget	Schedule / Status (Calendar Year)	Location	Service Area
Frazer Transportation Building				
Construction of a new transportation building at SEPTA's Frazer Railroad facility to accommodate the expanded staff, including train crews, and provide functional quarters for the Yardmaster. This project was initially included within the scope of the Frazer Rail Shop and Yard project. However, the scope and budget of the project warrants it being funded and managed separately from the Frazer Rail Shop and Expansion Project.	\$25.00 M	Design 2023 – 2025 Construction 2026 – 2028	Chester	System-wide
Garage / Shop Overhead Doors				
Replacement of overhead and fire doors, which have exceeded their useful life, at various SEPTA facilities	\$7.0 M	Design & Construction 2029 - 2035	Delaware Philadelphia	Bucks Delaware Philadelphia
Maintenance Shop Equipment Program				
Annual replacement of shop equipment such as lifting jacks, wash tanks, lathes, diagnostic tools, and grip cranes. This is an ongoing systemwide program to address critical needs to keep the SEPTA system operating reliably and safely.	\$51.80 M	Ongoing	Bucks Chester Delaware Montgomery Philadelphia	System-wide
Powelton Yard Facility Improvements				
Improvements to the Powelton Yard Facility including building repairs, new windows, new bathrooms, and replacement of the storeroom facility currently housed in a former railroad boxcar. Design is complete.	\$5.53 M	Construction 2021 - 2024	Philadelphia	Philadelphia

MAINTENANCE/TRANSPORTATION SHOPS AND OFFICES

Project Descriptions	Budget	Schedule / Status (Calendar Year)	Location	Service Area
<p>Steel Wheel Lift Program</p> <p>Rebuilding/modernization or replacement of truck and body hoist systems at various SEPTA steel wheel shops. These hoists are used to facilitate body and truck separation and to elevate railcars to safe heights and hold them as required to perform inspections and repairs under the rail vehicles.</p>	\$12.32 M	Design & Construction 2023 - 2029	Bucks Chester Delaware Montgomery Philadelphia	System-wide
<p>Vehicle Washer Program</p> <p>Replacement and upgrading of the vehicle washers, which have exceeded their useful life, at various SEPTA facilities.</p>	\$20.00 M	Design & Construction 2024 - 2033	Delaware Montgomery Philadelphia	System-wide
<p>Wheel Truing Program</p> <p>Reconditioning and rebuilding wheel truing machines that have exceeded their useful life.</p>	\$10.50 M	Design & Construction 2024 - 2028	Delaware Philadelphia	System-wide
<p>Wyoming Complex Stormwater Retrofits</p> <p>Reconfigure stormwater management and improve pavement conditions in the existing parking lot at SEPTA's Wyoming Complex which includes Wyoming, Berridge and Courtland shops. The project is being implemented in partnership with the Philadelphia Water Department. Design was completed in 2021.</p>	\$13.35 M	Construction 2022 - 2025	Philadelphia	Philadelphia

MAINTENANCE/TRANSPORTATION SHOPS AND OFFICES

Project Descriptions	Budget	Schedule / Status (Calendar Year)	Location	Service Area
<p>Victory Shop and Storage</p> <p>Replacement of the existing deteriorated shop and storage facilities located at 103 Victory Avenue. Work also includes improvements to parking and vehicle circulation, installation of a stormwater management system and replacement of the salt dome.</p>	\$18.75 M	Design 2024 Construction 2025 - 2027	Delaware	Delaware Montgomery Philadelphia
<p>1234 Market Street Headquarters Improvements</p> <p>The 1234 Market Street office building was built in 1973 and has served as SEPTA's Headquarters since June 1994. Many critical building components are beyond their useful life and require rehabilitation. This project includes repairs and replacements of existing electrical switchgear, elevators, life safety systems, and HVAC units. Additionally, SEPTA will evaluate building space utilization and implement changes to maximize the building's efficiency and marketability to maximize leasing opportunities.</p>	\$10.00 M	Design and Construction 2024 - 2032	Philadelphia	Philadelphia

MAINTENANCE/TRANSPORTATION SHOPS AND OFFICES

Project Descriptions	Budget	Schedule / Status (Calendar Year)	Location	Service Area
Zero Emission Bus (ZEB) Fleet Transition Facility Upgrades				
<p>While public transit is already a sustainable form of transportation compared to single-occupancy vehicles, transit agencies have an opportunity to further contribute to regional and national greenhouse gas reduction goals and improve local air quality by transitioning away from diesel-powered buses. SEPTA is planning for a full transition to ZEBs, which could include a combination of Battery Electric Buses and Fuel Cell Electric Buses, by the year 2040, if adequate funding is made available for the investments that will be necessary to charge and fuel these new buses.</p> <p>SEPTA has secured \$27.66 M for ZEB infrastructure projects through the FTA’s Low or No Emissions Vehicle Program. SEPTA will design, procure, and install additional or upgraded electric utility infrastructure for redundant power supplies at Midvale, Allegheny, Callowhill, and Comly bus depots including redundant power feeders, backup generators, and electrical substations. These upgrades will make it possible for SEPTA to start procuring a significant number of ZEBs in the next few years. SEPTA will continue to apply for funds through the FTA Low-No program to advance this transition.</p>	\$50.00 M	<p>Design 2024 – 2025</p> <p>Construction 2026 - 2028</p>	System-Wide	System-Wide
Maintenance & Transportation Facilities (FY 2029 – 2035)				
Maintenance Facilities Improvement Program				
<p>This project will address the conditions at SEPTA’s various maintenance facilities and implement necessary improvements to improve safety and efficiency. Facilities will be identified and budgeted for improvements.</p>	\$35.00 M	<p>Evaluation & Implementation 2029 - 2035</p>	Regionwide	Regionwide

MAINTENANCE/TRANSPORTATION SHOPS AND OFFICES

Project Descriptions	Budget	Schedule / Status (Calendar Year)	Location	Service Area
Roof Program (FY 2024 – 2035)				
5800 Bustleton Roof Replacement				
Replacement of the roof at SEPTA’s office building located at 5800 Bustleton Avenue.	\$1.75 M	Design & Construction 2024 - 2025	Philadelphia	Philadelphia
Frankford Depot Roof Replacement				
Replacement of the Frankford Depot roof with a new roofing system. Includes replacement of mechanical equipment.	\$18.80 M	Design 2023-2024 Construction 2024 - 2026	Philadelphia	Philadelphia
Maintenance, Stations, and Substations Roof Program				
Replacement and upgrade of the existing roofs at maintenance facilities, stations and substations throughout the SEPTA system. Work may include replacement of mechanical equipment.	\$19.50 M	Ongoing	Bucks Chester Delaware Montgomery Philadelphia	System-wide
Midvale Bus Garage Roof Replacement				
Replacement of existing roofs with a new roofing system and mechanical equipment.	\$29.90 M	Construction 2020 - 2024	Philadelphia	Philadelphia
Southern Garage Roof Replacement				
Replacement and upgrade of the existing roof system at Southern Garage.	\$13.00 M	Design & Construction 2027 - 2030	Philadelphia	Philadelphia

PROJECTS OF SIGNIFICANCE

SEPTA and its regional partners continue to advance key Projects of Significance to build towards a shared lifestyle transit network vision for Southeastern Pennsylvania. These projects are instrumental to ensuring SEPTA is able to achieve the goals set forth in our strategic plan, SEPTA Forward. SEPTA's Bus Revolution, Trolley Modernization and railcar replacement projects are all critical links to ensuring SEPTA achieves its goal for a more resilient, prosperous and equitable region for everyone, with transit at the core.



69th Street Transportation Center

Projects of Significance - Program Elements (\$ Millions)	Prior Funding	FY 2024	FY 2025	FY 2026	FY 2027	FY 2028	FY 2029 - 2035	12-Year Program Total	Unfunded Balance	Total Budget
Bus Revolution	\$34.48	\$15.25	\$21.30	\$19.26	\$6.86	\$4.00	\$62.00	\$128.97	\$0.00	\$163.15
Rail Transit Vehicle Acquisition	\$0.00	\$35.00	\$56.00	\$72.03	\$108.00	\$99.14	\$579.84	\$950.00	\$0.00	\$950.00
Regional Rail Vehicle Acquisition	\$0.00	\$5.00	\$30.00	\$30.00	\$65.00	\$45.00	\$475.00	\$650.00	\$600.00	\$1,250.00
Trolley Modernization	\$233.53	\$157.17	\$109.35	\$96.98	\$199.87	\$146.06	\$690.33	\$1,399.75	\$616.71	\$2,250.00
Regional Rail Master Plan	\$0.00	\$0.60	\$0.60	\$0.60	\$0.60	\$0.60	\$0.00	\$3.00	\$0.00	\$3.00
Projects of Significance Total	\$268.01	\$213.01	\$217.25	\$218.86	\$380.34	\$294.80	\$1,807.17	\$3,131.43	\$1,216.71	\$3,399.43



Bus Revolution



Trolley Modernization

PROJECTS OF SIGNIFICANCE

Project Descriptions	Budget	Schedule / Status (Calendar Year)	Location	Service Area
Bus Revolution (FY 2024 – 2035)				
Bus Network Enhancement Projects				
<p>A key goal of Bus Revolution is to ensure SEPTA’s bus network is more equitable by increasing opportunities for low-income individuals and people of color, who rely on public transportation to meet their needs more than the population at large. Projects will be informed by the results of Bus Revolution to ensure investments serve the people most dependent on transit resulting in better service and customer experience. These infrastructure improvements include but are not limited to right-of-way enhancements including transit priority measures, bus end of line facilities, bus wayfinding, and enhanced bus stops.</p> <p>Locations for End of Line facilities identified through Bus Revolution include Knights Road, Ivy Ridge, Germantown, Neshaminy Mall, & Willow Grove. SEPTA will utilize funds to acquire property where necessary, design, and construct the facilities.</p>	\$91.13 M	Property Acquisition, Design & Construction 2022 – 2035	System-Wide	System-Wide
Exton Station Multimodal Improvements				
<p>Initiate design and implement Phase 2 of Exton Station Multimodal Improvements project on the Paoli-Thorndale Regional Rail Line. This phase will design and implement multimodal improvements, including the construction of a bus loop with bus shelter. Derived from the recommendations of Bus Revolution, the planned bus circulator loop will promote intermodal access to the station.</p>	\$6.00 M	Design & Construction 2023 – 2026	Chester	Chester

Project Descriptions	Budget	Schedule / Status (Calendar Year)	Location	Service Area
<p>South Philadelphia Transportation Center</p> <p>Work on a new South Philadelphia Transportation Center, which was selected by the Federal Transit Administration (FTA) to receive \$9.8 M in grant funding to construct new end of line facilities in South Philadelphia for both east-west & north-south routes.</p>	\$12.25 M	Property Acquisition, Design & Construction 2023 – 2027	Philadelphia	Philadelphia
<p>Wissahickon Transportation Center</p> <p>This project will expand and improve the Wissahickon Transportation Center (WTC) in Philadelphia to effectively accommodate its ridership and enhance the transportation network, intermodal connections, and access to jobs and essential services. Expansion of the WTC will allow vehicles and pedestrians to safely navigate the area while reducing congestion. These improvements will strategically position the facility for future connectivity with the Roosevelt Boulevard Direct Bus project. Design is complete.</p>	\$45.16 M	Construction 2023 – 2025	Philadelphia	Montgomery Philadelphia
<p>Micro Transit Service Implementation</p> <p>Micro transit is a new on demand mode designed to improve service delivery in low-density, suburban jurisdictions. The mode will use new, smaller vehicles. The new vehicle specification will be coordinated with CCT for future paratransit fleet procurements.</p>	\$6.11 M	Vehicle Acquisition & Implementation 2025 – 2026	Philadelphia	Bucks Chester Delaware Montgomery

PROJECTS OF SIGNIFICANCE

Project Descriptions	Budget	Schedule / Status (Calendar Year)	Location	Service Area
Rail Vehicle Replacement Program (FY 2024 – 2034)				
Market-Frankford Line Vehicle Replacement				
<p>This project will purchase modern trainsets to replace the aging Market-Frankford Line M-4 Railcars. Included within the project’s budget is vehicle specification development, as well as signal system and other infrastructure improvements needed to enhance operational efficiency of the new railcars.</p> <p>Modernization of the signal system on the Market-Frankford Line will improve operational reliability for the train control systems on the entire corridor.</p> <p>MLF vehicle design was completed in 2022.</p>	\$950.00 M	Rail Vehicle Acquisition 2025 – 2031 Design 2024 – 2025 Construction 2026 – 2030	Delaware Philadelphia	Delaware Philadelphia
Regional Rail Cars Silverliner IV Replacement				
<p>The Silverliner IV railcar fleet was manufactured between 1974 and 1976 and are closely approaching 50 years of service. An investment in the replacement of the aging fleet will provide vehicle specification, infrastructure improvements, and enable SEPTA to consider a partial fleet replacement that supports implementation of Reimagining Regional Rail.</p>	\$650.00 M	Implementation 2028 – 2034	Bucks Chester Delaware Montgomery Philadelphia	System-Wide

Project Descriptions	Budget	Schedule / Status (Calendar Year)	Location	Service Area
----------------------	--------	--------------------------------------	----------	--------------

Trolley Modernization (FY 2024 – 2035)

<p>SEPTA is committing a total of \$1.633 billion for the Trolley Modernization program. These capital funds enable SEPTA to advance the acquisition of 130 new ADA accessible trolleys to replace the Authority’s aging fleet and upgrade trolley network infrastructure to improve accessibility, capacity, reliability, and safety.</p>				
<p>SEPTA’s Trolley system is the largest in North America and serves tens of thousands of transit-dependent riders in Philadelphia and Delaware counties every day. The current vehicles are over 40 years old and were acquired prior to the passage of ADA – meaning people with disabilities, seniors, and anyone with mobility issues or using a stroller cannot take full advantage of the connections they provide. Trolley Modernization opens the doors to these communities with new, low-floor vehicles and improved track infrastructure that will make the system fully ADA accessible.</p>	<p>Trolley Vehicles \$790.00 M</p>	<p>Trolley Acquisition 2023 – 2030</p>	<p>Delaware Philadelphia</p>	<p>Delaware Philadelphia</p>
<p>This program advances equity by improving trolley access and service that disproportionately serves people of color, low-income populations, and individuals with disabilities. SEPTA’s Trolley Modernization Project will catalyze over 38,000 permanent jobs and create an increase of \$5.8 billion in property values across the region. Specific activities include the following:</p> <ul style="list-style-type: none"> • Acquisition of 130 new, 84-foot ADA accessible trolley vehicles. • Property acquisition, design, and construction of a new Trolley Maintenance Facility in Southwest Philadelphia. • ADA Accessibility and State of Good Repair Improvements at 19th, 22nd, 33rd, 36th and 37th Street Trolley Stations. • Trolley Tunnel State of Good Repair Program, including the overhaul of the 40th Street Substation • Design of modern stations and identification of new station locations with public input and community engagement • Study and advancement of end-of-line improvements and extensions • Coordination with utilities, the City of Philadelphia, and Delaware County <p>Preliminary engineering and design for Bridge, Communication & Signals, Power, and Track system upgrades</p>	<p>Trolley Modernization Infrastructure \$843.29 M</p>	<p>Design & Construction 2023 – 2035</p>		
	<p>Balance Needed for Program: \$616.71 M</p>			

PROJECTS OF SIGNIFICANCE

Project Descriptions	Budget	Schedule / Status (Calendar Year)	Location	Service Area
<p>69th Street Transportation Center Comprehensive Plan Implementation</p> <p>Development of a comprehensive master plan and undertake early actions to rehabilitate and improve service and the customer experience at the 69th Street Transportation Center. These infrastructure and intermodal connectivity improvements are critical to the success of Trolley Modernization and Bus Revolution.</p>	\$4.00 M	Design and Early Actions 2022 – 2024	Delaware	Delaware Montgomery Philadelphia
<p>Regional Rail Master Plan Implementation</p> <p>This process will progress concepts and alternatives evaluated through the Regional Rail Master Plan effort, including more detailed alternative analysis and concept design. Work may include progression of appropriate NEPA work with a focus on increasing grant-program readiness. Specific components for further study are currently being identified but will include continued coordination with external stakeholders.</p>	\$3.00 M	Implementation Ongoing	System-Wide	System-Wide

SAFETY AND SECURITY IMPROVEMENTS

Safety is a core value at SEPTA. All projects advanced in the capital program have a safety-first focus throughout. Having a comprehensive safety plan and program is part of SEPTA’s goal to promote safety and public health. This program includes life safety assessments and facility and vehicle safety and security measures. This program also includes projects funded with competitive U. S. Department of Homeland Security grant funds. The Authority is part of the Philadelphia Area Regional Transit Security Working Group (PARTSWG), which is working to advance safety and security improvements for all transit operations into and out of Philadelphia and the surrounding area.



Jefferson Station Ventilation

Safety and Security Improvements - Program Elements (\$ Millions)	Prior Funding	FY 2024	FY 2025	FY 2026	FY 2027	FY 2028	FY 2029 - 2035	12-Year Program Total	Total Budget
Resiliency & Recovery Projects	\$95.87	\$23.59	\$13.11	\$6.00	\$12.00	\$2.00	\$5.00	\$61.71	\$157.57
Safety and Security Projects	\$48.36	\$24.55	\$36.17	\$24.98	\$20.33	\$29.06	\$158.73	\$293.83	\$342.20
Transit Security Grant Projects	-	\$2.38	\$1.00	\$1.00	\$1.00	\$1.00	\$7.00	\$13.38	\$13.38
Safety and Security Improvements Total	\$144.23	\$50.53	\$50.28	\$31.98	\$33.33	\$32.06	\$170.73	\$368.92	\$513.15



Grade Crossing Enhancement Program

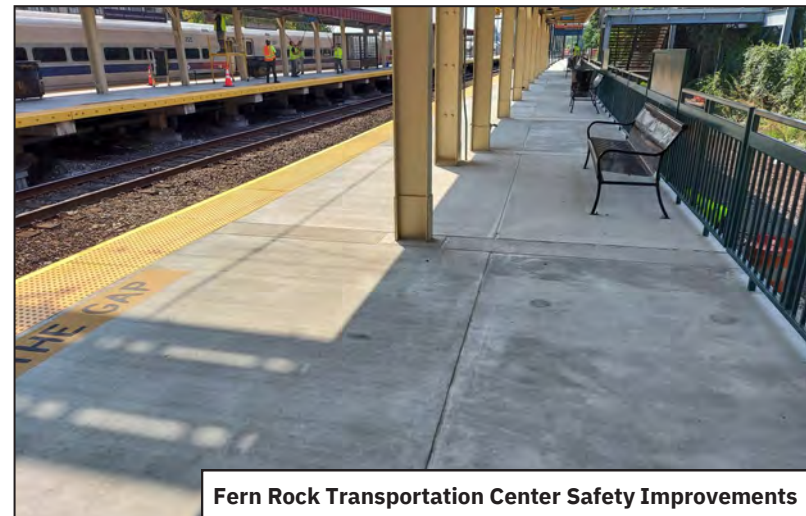

Fern Rock Transportation Center Safety Improvements

Project Descriptions	Budget	Schedule / Status (Calendar Year)	Location	Service Area
Resiliency Projects (FY 2024 - 2025)				
Jenkintown Flood Mitigation				
<p>Implementation of a drainage improvement program at Jenkintown Station, a key hub in the Regional Rail network. The project will include: 1) A comprehensive study of the drainage patterns and contributory areas (Tacony Creek, Baeder Creek, and Tookany Creek) and suggested improvements to downstream best management practices; 2) The design and construction of a new box culvert and detention system at Culvert 10.38; 3) The design and construction of reinforcements to Bridge 10.97 or replacement, including the stabilization of area structures and a rainwater detention system; and Construction to widen the stream North of Jenkintown Station. Design is complete.</p>	\$19.98 M	Construction 2022 – 2024	Montgomery	Bucks Montgomery Philadelphia
Railroad Signal Power Reinforcement				
<p>This project will upgrade the Regional Rail Signal Power System to significantly improve the reliability of SEPTA’s Railroad through a new powering system. The new power system will consist of a local utility feed with solar and battery power as a back-up. Upon completion, all SEPTA owned Railroad lines will have a resilient signal power system. Design is complete.</p>	\$43.23 M	Construction 2019 – 2025	Bucks Montgomery Delaware Philadelphia	System-Wide

SAFETY AND SECURITY IMPROVEMENTS

Project Descriptions	Budget	Schedule / Status (Calendar Year)	Location	Service Area
Sharon Hill Line Flood Mitigation				
This project will provide the Route 102 Sharon Hill Trolley Line flooding relief by constructing a pumped drainage system where the Sharon Hill Trolley crosses under a freight railroad bridge at Mile Post 5.30 in Delaware County. This frequently flooded underpass forces SEPTA to rely on a bus substitution program to detour service around the high-water area more than a dozen times each year. Bus substitution is employed at a significant cost and disruption to passengers. Design is complete.	\$15.37M	Construction 2018 – 2024	Delaware	Delaware
Safety and Security Projects (FY 2024 - 2035)				
Escalator / Elevator Improvement Program				
This is an ongoing systemwide program to address critical needs to keep the SEPTA system operating reliably and safely by modernizing and upgrading escalators and elevators throughout the SEPTA system. Work includes design, construction, and integration of an escalator remote monitoring system.	\$76.00 M	Ongoing	Philadelphia	System-Wide
Fern Rock Transportation Center Safety Improvements				
Safety improvements at the Fern Rock Transportation Center Regional Rail Station, which serves the Lansdale/Doylestown, Warminster and West Trenton Regional Rail Lines and provides connecting service to the Broad Street Line. Work includes overhauling the elevator, platform repairs, fencing installation, lighting, and related station modifications. Design was completed in 2022.	\$17.26 M	Construction 2019 – 2025	Philadelphia	Bucks Montgomery Philadelphia

SAFETY AND SECURITY IMPROVEMENTS

Project Descriptions	Budget	Schedule / Status (Calendar Year)	Location	Service Area
<p>Fern Rock Transportation Center Pedestrian Access</p> <p>This project will provide an undergrade pedestrian connection from the neighborhood immediately east of Fern Rock Transportation Center. SEPTA is working with the City of Philadelphia to determine the safest, most accessible, and efficient path of travel for this connection.</p>	\$25.00 M	<p>Design 2024– 2025</p> <p>Construction 2033 – 2035</p>	Philadelphia	<p>Bucks Montgomery Philadelphia</p>
<p>Grade Crossing Enhancement Program</p> <p>This safety project will renew and upgrade various railroad and trolley highway/rail grade crossing locations within the SEPTA system, including the addition of passive and/or active safety enhancements.</p>	\$20.82 M	Ongoing	<p>Bucks Delaware Montgomery Philadelphia</p>	System-Wide
<p>Safety and Security Infrastructure Hardening Program</p> <p>Infrastructure improvements and modifications throughout the SEPTA system will improve safety and security of both passengers and assets.</p> <p>This program includes but is not limited to culvert and retaining wall replacements and renewal. It will also allow SEPTA to perform analysis and conceptual design of key safety and security initiatives. This is an ongoing systemwide program to address critical needs to keep the SEPTA system operating reliably and safely.</p>	\$50.00 M	Ongoing	<p>Bucks Delaware Montgomery Philadelphia</p>	System-Wide

SAFETY AND SECURITY IMPROVEMENTS

Project Descriptions	Budget	Schedule / Status (Calendar Year)	Location	Service Area
<p>Safety and Security Shop, Yard, & Office Hardening</p> <p>Infrastructure improvements and modifications throughout SEPTA’s shops, yards, and offices to improve safety and security of employees and assets. This program includes but is not limited to fencing, lighting, and securement of materials. It also allows SEPTA to perform analysis and conceptual design of key safety and security initiatives. This is an ongoing systemwide program to address critical safety and security needs to keep the SEPTA system operating reliably and safely.</p>	\$40.00 M	Ongoing	Bucks Delaware Montgomery Philadelphia	System-Wide
<p>Safety & Security Technology Upgrades</p> <p>This project will fund critical infrastructure software and hardware investments necessary to address current and future security and functional needs. Funding includes upgrades for Positive Train Control (PTC) and SEPTA Key technology and system support.</p>	\$20.00 M	Implementation 2033 – 2035	Bucks Chester Delaware Montgomery Philadelphia	System-Wide
<p>Suburban Station Ventilation Improvements</p> <p>This project will consist of engineering services and third-party construction for Suburban Station replacement of the general ventilation systems. Suburban Station work includes replacement of 11 platform level exhaust fans and the installation of 8 vane axial exhaust/supply fans for the concourse level smoke abatement system. Design is complete.</p>	\$12.82 M	Construction 2022 – 2024	Philadelphia	System-Wide

Project Descriptions	Budget	Schedule / Status (Calendar Year)	Location	Service Area
<p>Tank Replacement Program</p> <p>Replacement or relining of storage tanks, which have exceeded their useful life, at various SEPTA facilities. This is an ongoing systemwide program to address critical needs to keep the SEPTA system operating reliably and safely.</p>	\$24.50 M	Ongoing	Bucks Chester Delaware Montgomery Philadelphia	System-Wide
<p>Regional Rail Grade Crossing</p> <p>This safety project will renew and upgrade various railroad and trolley highway/rail grade crossing locations within the SEPTA system, including the addition of passive and/or active safety enhancements. This project is being supported by two Federal Highway Administration (FHWA) Commuter Authority Rail Safety Improvement grants.</p>	\$22.00 M	Design and Construction 2023 – 2028	Bucks Delaware Montgomery	System-Wide
<p>NHSL Slope Stabilization at Rebel Hill</p> <p>The SEPTA Norristown High Speed Line (NHSL) passes adjacent to a near vertical rock cut between New Gulf Road and Interstate 76 (Schuylkill Expressway), in Upper Merion Township, Montgomery County known as Rebel Hill. Constant erosion from precipitation events has caused the rock slope through this area to become increasingly unstable over time. Consequently, falling rock debris has the potential to damage the NHSL Right-of-Way. The project will design and construct slope stabilization measures to mitigate these risks.</p>	\$22.00 M	Design and Construction 2025 – 2028	Delaware Montgomery	System-Wide

SAFETY AND SECURITY IMPROVEMENTS

Project Descriptions	Budget	Schedule / Status (Calendar Year)	Location	Service Area
Lawndale Station Grade Separation & High-Level Platform				
Construction of a grade separated pedestrian access to Lawndale Station on the Fox Chase Regional Rail Line. This project also includes the installation of a high-level platform and passenger shelters on the SEPTA platform.	\$22.00 M	Design and Construction 2017 – 2026	Philadelphia	Philadelphia
Safety and Security Projects (FY 2029 – 2035)				
NRG Station Ventilation Improvements				
Replacement and upgrade of the existing ventilation systems and installation of a smoke abatement system at NRG Station. Phase 1 is complete.	\$10.00 M	Phase 2 2034 – 2035	Philadelphia	Philadelphia
On-Site Power for Major Facilities				
Installation of emergency back-up power and power system upgrades and at major SEPTA maintenance and transportation facilities.	\$5.00 M	Construction 2030 – 2035	Bucks Chester Delaware Montgomery Philadelphia	System-Wide

Project Descriptions	Budget	Schedule / Status (Calendar Year)	Location	Service Area
Transit Security Grant Projects (FY 2024 - 2035)				
<p>Through the U.S. Department of Homeland Security (DHS), the competitive annual Transit Security Grant Program (TSGP) provides funds to operators of public transportation systems to protect critical surface transportation assets and the traveling public from acts of terrorism, and to increase the resilience of transit infrastructure. From this grant program, SEPTA has funded closed circuit television (CCTV) cameras on vehicles; multi-jurisdictional counter terrorism emergency simulation drills on various transit modes; directed SEPTA Transit Police Patrols in strategically designated areas during periods of elevated alert using specially trained anti-terrorism teams; hazardous material identification kits for Special Operations and Response Teams (SORT); purchase of explosive detection devices, intrusion detection and surveillance equipment, and bulletproof vests; Special Operations and Response Teams (SORT) and K-9 patrol teams; upgraded mobile communications and Control Center monitoring equipment; installation of video surveillance cameras at transit facilities; implementation of a radio interoperability system (RIOS); maintenance of a computer aided dispatch and records management system (CAD/RMS) for the Philadelphia region; and perimeter fencing and security cameras at SEPTA's Fern Rock facility. SEPTA will continue to fund eligible projects from this grant program.</p>	\$13.38 M	Ongoing	Bucks Chester Delaware Montgomery Philadelphia	System-Wide

SEPTA KEY PROGRAM

The SEPTA Key project is modernizing SEPTA’s antiquated fare payment and collection system by replacing it with a system that utilizes contactless payment devices and readers. Fare Kiosks located in stations and other terminal locations improve customer convenience for fare instrument purchases. Key Cards are also widely available in retail establishments throughout the SEPTA service area and are reloadable via the following methods: 1) at Fare Kiosks or ticket offices; 2) automatically through an account with SEPTA; or 3) through an on-line transaction or the Call Center.

SEPTA Key is unique as it includes all of SEPTA’s service modes. SEPTA Key deployment is complete for Transit services (Bus, Trolley, Trackless Trolley and High Speed Lines). Regional Rail deployment is complete with Center City station farelines, outer

station platform validators and on-board conductor handheld sales devices accepting credit/debit cards. CCT deployment/integration is complete. Parking Payment is partially deployed.

Other completed features include: school passes, Partner Portal for corporations, social service agencies & universities and mobile app ticketing for SEPTA Key. Key features still under development and being rolled out include upgraded Key Card readers, Key Tix and contactless payment/mobile wallets. The SEPTA Key project will be completed in 2024.

The SEPTA Board approved a loan agreement with the Philadelphia Industrial Development Corporation (PIDC), Limited Partnership (LP) XXVIII, to partially finance this project. The total project cost includes the loan repayment, interest, program management, and companion project costs.



SEPTA Key - Program Elements (\$ Millions)	Prior Funding	FY 2024	FY 2025	FY 2026	FY 2027	FY 2028	FY 2029- 2035	12-Year Program Total	Total Budget
SEPTA Key	\$309.45	\$5.55	-	-	-	-	-	\$5.55	\$315.00
SEPTA Key 2.0	\$12.00	\$3.57	\$40.00	\$45.00	\$45.00	\$40.00	\$54.67	\$228.24	\$240.24
SEPTA Key Program Total	\$321.45	\$9.12	\$40.00	\$45.00	\$45.00	\$40.00	\$54.67	\$233.79	\$555.24

The SEPTA Key 2.0 Fare Payment System project will upgrade the existing system to a next-generation, account based electronic fare collection system which is necessary to meet future needs to provide a more flexible and secure back-office system as well as the replacement of obsolete field equipment. The goals and objectives of the SEPTA Key 2.0 Fare Payment System support the implementation of the SEPTA Forward Strategic Plan including: improve the customer experience with simple, intuitive interfaces; use modern technology to streamline operations & reduce fare evasion; improve financial controls; maximize system flexibility with an open architecture to integrate with other mobility providers; enhance data security; and deploy equitable fare policies. In addition to the System Upgrade, SEPTA Key 2.0 will also include the following:

- Parking System- To support revenue collection at SEPTA controlled parking lots and garages. The Parking System will be integrated with the new core Fare Payment System and provide open lot, garage and permit parking.
- Continual Fare Media Order- This contract will provide for new forms of fare media inventory required to support future fare collection operations and sales. The types of fare media include:
 - Extended-Use Media (reloadable smart cards)
 - Limited-Use Media (Disposable Smart media aka DSM)
 - Paper Tickets (QR-code)
- Building Access System- SEPTA will procure the supplies, equipment and software required to support building access at designated SEPTA facilities accessed by SEPTA staff, contractors and building tenants.
- Call Center Operations- The build-out, equipping, and staffing of a call center to process inbound calls and contacts from SEPTA Key customers.

Procurement for SEPTA Key 2.0 is underway and the project will be implemented in 2024 through 2030.

SEPTA Key information is available online at <http://www.septakey.org>.

SERVICE RESTORATION

This program provides for the Coatesville Service Restoration project that will restore rail service on the Paoli/Thorndale Regional Rail Line from its existing terminus at Thorndale, Chester County, to a new terminus in Coatesville, Chester County. Regional Rail service beyond Thorndale was discontinued in 1996. PennDOT is currently reconstructing the Coatesville Station with completion anticipated in mid to late 2025. The new station will be ADA accessible and includes improved lighting, overhead canopies, elevators, and a passenger connection for crossing the tracks.

In order for SEPTA to restore Regional Rail service, additional track and signal infrastructure improvements are needed along the line. SEPTA, in coordination with PennDOT, Amtrak, & Chester County, will facilitate the design of track and signal infrastructure improvements that are necessary to operate an efficient service to Coatesville Station. While designing the infrastructure upgrades, SEPTA will coordinate with its partners to schedule implementation and secure funding for construction and operations.

Service Restoration & Enhancements - Program Elements (\$ Millions)	Prior Funding	FY 2024	FY 2025	FY 2026	FY 2027	FY 2028	FY 2029 - 2035	12-Year Program Total	Total Budget
Coatesville Service Restoration - Regional Rail	\$0.00	\$1.00	\$1.00	\$0.00	\$0.00	\$0.00	\$0.00	\$2.00	\$2.00
Service Restoration & Enhancements Total	\$0.00	\$1.00	\$1.00	\$0.00	\$0.00	\$0.00	\$0.00	\$2.00	\$2.00



Coatesville Station Site



Coatesville Track Upgrades

Photos courtesy of PennDOT

STATIONS, LOOPS AND PARKING IMPROVEMENTS

This program provides for the construction, reconstruction or rehabilitation of transit and regional rail stations and terminals, bus/trolley loop facilities, transportation centers, bicycle facilities, and parking expansions and improvements. Program elements include the replacement or rehabilitation of station and loop facility components, such as station buildings, ticket offices, waiting rooms, passenger shelters, canopies, platforms, crosswalks and overpasses, escalators and elevators, lighting and other security features, signage, and accessible paths. All improvements fully comply with requirements of the Americans with Disabilities Act (ADA). SEPTA currently has 109 wheelchair accessible railroad/rail transit stations.



Ardmore Transportation Center

Stations, Loops and Parking Improvements - Program Elements (\$ Millions)	Prior Funding	FY 2024	FY 2025	FY 2026	FY 2027	FY 2028	FY 2029 - 2035	12-Year Program Total	Total Budget
Multi-Modal Stations	\$0.50	\$3.90	\$0.00	\$0.00	\$0.00	\$0.00	\$0.00	\$3.90	\$4.40
Parking Improvements	\$31.59	\$7.00	\$8.05	\$1.70	\$0.00	\$0.00	\$0.00	\$16.75	\$48.33
<i>Conshohocken Station Parking</i>	\$31.59	\$7.00	\$8.05	\$1.70	\$0.00	\$0.00	\$0.00	\$16.75	\$48.33
Regional Rail Stations	\$110.05	\$30.78	\$32.51	\$40.98	\$43.13	\$43.62	\$249.15	\$440.18	\$550.23
<i>Ardmore Transportation Center - Phases 1 & 2</i>	\$45.00	\$7.00	\$1.60	\$0.00	\$0.00	\$0.00	\$0.00	\$8.60	\$53.60
<i>Cornwells Heights Station Reconfiguration</i>	\$16.00	\$3.00	\$3.00	\$0.00	\$0.00	\$0.00	\$39.00	\$45.00	\$61.00
<i>Paoli Transportation Center - Phases 1 & 2</i>	\$0.00	\$0.00	\$0.00	\$0.00	\$0.00	\$0.00	\$50.28	\$50.28	\$50.28
<i>Villanova Station - Phases 1 & 2</i>	\$0.00	\$0.35	\$3.16	\$6.94	\$0.00	\$0.00	\$0.00	\$10.45	\$10.45
Transit Stations	\$283.33	\$45.31	\$55.95	\$62.59	\$68.11	\$58.10	\$213.53	\$503.59	\$786.92
<i>City Hall & 15th Street Station</i>	\$86.72	\$2.12	\$16.03	\$17.77	\$23.40	\$27.00	\$16.00	\$102.31	\$189.04
Stations, Loops and Parking Improvements Total	\$425.46	\$86.99	\$96.52	\$105.27	\$111.24	\$101.73	\$462.67	\$964.42	\$1,389.88



Susquehanna-Dauphin Station and ADA Accessibility Improvements



Tasker-Morris Station Rendering

STATIONS, LOOPS AND PARKING IMPROVEMENTS

Project Descriptions	Budget	Schedule / Status (Calendar Year)	Location	Service Area
Multi-Modal Station Improvements and ADA Accessibility Projects (FY 2024 – 2033)				
ADA Bridge Plates				
<p>This project will provide replacement and additional bridge plates at rail stations to assist passengers with disabilities or special needs to board railcars over gaps that exist between station platforms and vehicles.</p>	\$4.40 M	Design & Procurement 2020 - 2024	Bucks Chester Delaware Montgomery Philadelphia	System-wide
Bicycle Transit Access Program				
<p>Installation of new bicycle parking shelters and racks and improved bicycle access at select SEPTA stations. The addition of bicycle parking shelters and racks and improving bicycle access and security at SEPTA stations will encourage more customers to bike to transit and expand opportunities to access SEPTA stations.</p>	\$2.50 M	Ongoing to 2033	System-wide	System-wide

STATIONS, LOOPS AND PARKING IMPROVEMENTS

Project Descriptions	Budget	Schedule / Status (Calendar Year)	Location	Service Area
Center City Concourses				
<p>Multi-phase improvements to the Center City Concourses to enhance accessibility and bring the concourse network to a state of good repair. This program includes new finishes, lighting and security features structural rehabilitation, new drainage, and electrical upgrades.</p> <p>Major capital improvements will be advanced in the following phases:</p> <ul style="list-style-type: none"> • Phase 1 (Complete): Center Square under South Penn Street passing over South Broad concourse and terminating at Juniper Street. • Phase 2: East Suburban Station entrance adjacent to Love Park continuing in front of the Municipal Services Building and terminating at the Market East Concourse (North). • Phase 3: (Complete) Concourse from 15th Street Station to Dilworth Park and West Trolley entrance. • Phase 4: East Market Street Concourse (North and South Corridors). • Phase 5: 8th Street concourse on North and South side of Market Street including structural repairs and water proofing, • Phase 6: Corridor from City Hall Station to Juniper Street. • Phase 7: Corridors in Suburban Station between 17th and 16th Streets. • Phase 8: South Broad Concourse from City Hall to Spruce Street. 	\$59.65 M	<p>Phase 2 & 4: Design 2020 - 2023</p> <p>Construction 2021 - 2024</p> <p>Phase 5: Construction 2023 - 2024</p> <p>Phases 6 – 8: Design & Construction 2024 - 2030</p>	Philadelphia	Philadelphia

STATIONS, LOOPS AND PARKING IMPROVEMENTS

Project Descriptions	Budget	Schedule / Status (Calendar Year)	Location	Service Area
Rail Transit Wayfinding & Signage				
<p>SEPTA will redesign and replace the wayfinding & signage system for its Rail Transit network, which includes the Market-Frankford Line, Broad Street Line, Norristown High Speed Line, Trolleys, and Media-Sharon Hill Lines. The project will include new station identification signage and pylons, directional signage, platform signage, in-vehicle signage, regulatory signage, and system, line and station area maps. The signs will utilize clear, accessible, and consistent standard service communications language and graphic standards outlined in an updated wayfinding and signage manual.</p>	\$40.00 M	Design & Implementation 2021 - 2026	Delaware Montgomery Philadelphia	Delaware Montgomery Philadelphia
Regional Rail Station ADA Accessibility and Improvement Program (FY 2024 – 2035)				
Ardmore Transportation Center on the Paoli/Thorndale Line				
<p>Improvements to the Ardmore Transportation Center on the Paoli/Thorndale Regional Rail Line will be completed in two phases.</p>	Phase 1: \$53.60 M	Phase 1: Construction 2019 - 2025	Montgomery	Chester Delaware Montgomery Philadelphia
<p>Phase 1 will make this station fully ADA accessible with enhancements that include a new inbound station building; outbound shelters; high and low-level platforms; canopies; passenger amenities; tunnel accessibility improvements; elevators and accessible pathways; improved lighting; new signage; landscaping and site improvements including stormwater management; and installing foundations for a future parking garage.</p>	Phase 2: TBD	Phase 2: TBD		
<p>Phase 2 includes the construction of an accessible multi-level parking garage with approximately 500 spaces; landscaping; site improvements; bus berthing area inside the garage; and improved vehicle and pedestrian access to Lancaster Avenue. Due to reduced ridership resulting from the COVID-19 pandemic and in conjunction with the Reimagining Regional Rail initiative, SEPTA is re-evaluating its station parking project schedules. A schedule and funding plan for Phase 2 will be developed as ridership levels increase and the necessity for additional parking becomes clearer.</p>				

STATIONS, LOOPS AND PARKING IMPROVEMENTS

Project Descriptions	Budget	Schedule / Status (Calendar Year)	Location	Service Area
<p>Bristol Station on the Trenton Line</p> <p>This project will make the Bristol Station on the Trenton Regional Rail Line fully ADA accessible and includes full length high-level platforms, new passenger shelters, security improvements and passenger amenities.</p>	\$30.00 M	<p>Design 2022 - 2023</p> <p>Construction 2024 - 2026</p>	Bucks	<p>Bucks Philadelphia New Jersey</p>
<p>Chestnut Hill East Station on the Chestnut Hill East Line</p> <p>Accessibility improvements at the Chestnut Hill East Regional Rail Station include construction of a high-level platform, station building improvements and an ADA accessible pathway at the station.</p>	\$11.17 M	<p>Design 2021 - 2023</p> <p>Construction 2023 - 2026</p>	Philadelphia	Philadelphia
<p>Conshohocken Station on the Manayunk/Norristown Line</p> <p>This project provides for design and construction of a new fully ADA accessible station, and station access improvements at Conshohocken Station on the Manayunk/Norristown Regional Rail Line. This station will receive new full length high-level platforms; new station building and passenger shelters; accessible pathways, sidewalks and handrails/guardrails; bike facilities; additional roadway access to the station; new signage and lighting; stormwater management systems and landscaping.</p>	\$15.92 M	<p>Construction 2020 - 2025</p>	Montgomery	<p>Montgomery Philadelphia</p>

STATIONS, LOOPS AND PARKING IMPROVEMENTS

Project Descriptions	Budget	Schedule / Status (Calendar Year)	Location	Service Area
----------------------	--------	--------------------------------------	----------	--------------

Cornwells Heights Station Reconfiguration on the Trenton Line

This project will make the station Cornwells Heights Station on the Northeast Corridor, serving Amtrak Keystone Services trains and the SEPTA Trenton Line Regional Rail Line fully ADA accessible and includes full length high-level platforms, new passenger shelters, security improvements and passenger amenities. The reconstructed station will have a pedestrian overpass with elevators between the platforms that will allow safe, convenient movement between the two platforms and the parking lots on its north side.

\$61.00 M

Design
2024 - 2025

Construction
2032 - 2035

Bucks

Bucks
Philadelphia

Exton Station on the Paoli/Thorndale Line

This project provides for the phasing of improvements at Exton Station on the Paoli/Thorndale Regional Rail Line.

Phase 2:
\$6.00 M

Phase 2:
Design & Construction
2023 – 2026

Construction
TBD

Chester

Chester
Delaware
Montgomery
Philadelphia

Phase 2 includes the construction of bus loops with bus shelters. The planned bus circulator loops will promote intermodal access to the station. This phase is included within the Projects of Significance - Bus Revolution section of the capital budget.

Phase 3 will provide for the development and construction of a fully accessible parking expansion. **Due to reduced ridership resulting from the COVID-19 pandemic and in conjunction with the Reimagining Regional Rail initiative, SEPTA is re-evaluating its station parking project schedules. A schedule and funding plan for Phase 3 will be developed as ridership levels increase and the necessity for additional parking becomes clearer.**

Phase 3:
TBD

Phase 3:
TBD

STATIONS, LOOPS AND PARKING IMPROVEMENTS

Project Descriptions	Budget	Schedule / Status (Calendar Year)	Location	Service Area
Jenkintown-Wyncote Station on the Regional Rail Mainline				
Improvements that will make the station fully ADA accessible. This station will receive new full length high-level platforms; new pedestrian overpass and elevators; new passenger shelters; accessible pathways and handrails/guardrails; new signage and lighting; stormwater management systems and landscaping.	\$50.28 M	Design 2016 - 2024 Construction 2024 - 2029	Montgomery	Bucks Montgomery Philadelphia
Malvern Station on the Paoli/Thorndale Line				
This project will make the station fully ADA accessible and includes full length high-level platforms, new passenger shelters, security improvements and passenger amenities.	\$15.26 M	Design 2023 - 2025 Construction 2026 - 2028	Chester	Chester Montgomery Philadelphia
Marcus Hook Station on the Wilmington Line				
This project will make the station fully ADA accessible and includes full length high-level platforms, new passenger shelters, security improvements and passenger amenities.	\$22.50 M	Design 2023 - 2025 Construction 2027 - 2029	Delaware	Delaware Philadelphia Delaware (State)

STATIONS, LOOPS AND PARKING IMPROVEMENTS

Project Descriptions	Budget	Schedule / Status (Calendar Year)	Location	Service Area
<p>Noble Station on the West Trenton Line</p> <p>Construction to make the station ADA accessible and provide a storage track for operational efficiency at Noble Station on the West Trenton Regional Rail Line. Work will make the station fully ADA accessible and includes full length high-level platforms; canopies and passenger shelters; accessible pathways, sidewalks and handrails/ guardrails; new signage, lighting and security cameras; stormwater management systems and landscaping. SEPTA is coordinating this project with PennDOT’s replacement of the adjacent Route 611 bridge. Phase 1 includes stairs and ramps that connect to PennDOT Route 611 Bridge. The remainder of the project will be completed in Phase 2.</p>	<p>\$28.20 M</p>	<p>Phase 1: Construction 2023-2025</p> <p>Phase 2: Design 2023 - 2024</p> <p>Construction 2026 - 2029</p>	<p>Montgomery</p>	<p>Bucks Montgomery Philadelphia New Jersey</p>

STATIONS, LOOPS AND PARKING IMPROVEMENTS

Project Descriptions	Budget	Schedule / Status (Calendar Year)	Location	Service Area
Paoli Transportation Center on the Paoli/Thorndale Line				
<p>This project provides for the engineering and construction of a new multimodal transportation center in Paoli, Chester County. The facility is located on SEPTA's Paoli/Thorndale Regional Rail Line and Amtrak's Harrisburg Line. Connecting services include Bus Routes 92, 106, 204, and 206.</p>	<p>Phase 2: \$50.28 M</p>	<p>Phase 2: Design & Construction 2029 - 2035</p>	<p>Chester</p>	<p>Chester Delaware Montgomery Philadelphia</p>
<p>The project includes three phases. Phase 1, completed in September 2019, made the existing station ADA accessible.</p>	<p>Phase 3: TBD</p>	<p>Phase 3: TBD</p>		
<p>Phase 2 includes construction of an additional high-level platform on the outbound side, passenger amenities, enhanced bus facilities, improved station access. A companion PennDOT project will consist of the extension of Darby Road over the railroad, including a new bridge connecting to the station, and the removal of the North Valley Road bridge. This companion project needs to be completed prior to advancement of Phase 2.</p>				
<p>Phase 3 includes the construction of an accessible multi-level parking garage. Due to reduced ridership resulting from the COVID-19 pandemic and in conjunction with the Reimagining Regional Rail initiative, SEPTA is re-evaluating its station parking project schedules. A schedule and funding plan for Phase 3 will be developed as ridership levels increase and necessity for additional parking becomes clearer.</p>				
Regional Rail Station Roof Program				
<p>Ongoing program for repair, renewal, and/or replacement of station roofs along the Regional Rail network.</p>	<p>\$13.06 M</p>	<p>Ongoing</p>	<p>Bucks Chester Delaware Montgomery Philadelphia</p>	<p>System-wide</p>

STATIONS, LOOPS AND PARKING IMPROVEMENTS

Project Descriptions	Budget	Schedule / Status (Calendar Year)	Location	Service Area
Swarthmore Station on the Media/Elwyn Regional Rail Line				
Improvements to the ADA path of travel at the Swarthmore Station on the Media/Elwyn Regional Rail Line. Work includes improvements to tunnel and new ramps between tunnel and platforms.	\$7.96 M	Design & Construction 2022 - 2025	Delaware	Delaware Philadelphia
Willow Grove Station on the Warminster Regional Rail Line				
Relocation of Willow Grove Station on the Warminster Regional Rail Line will make the station fully ADA accessible and address traffic congestion issues on Rt 611 near the existing station.	\$44.00 M	Phase 2: Construction 2024 - 2029	Montgomery	Bucks Montgomery Philadelphia
Phase 1 work was completed in 2023 and included track realignment and related right-of-way improvements. Phase 2 work will include new full length high-level center platform passenger shelters; accessible pathways and handrails/ guardrails; improved station access; parking expansion; new signage and lighting; stormwater management systems; and landscaping.				
Villanova Station on the Paoli/Thorndale Regional Rail Line				
This project will make the station fully ADA accessible and includes full length high-level platforms, new canopies, station building improvements, passenger shelters, security improvements and passenger amenities. Phase 1 was completed in 2019.	Phase 2: \$10.45 M	Phase 2: Final Design & Construction 2024 - 2026	Delaware	Chester Delaware Montgomery Philadelphia

STATIONS, LOOPS AND PARKING IMPROVEMENTS

Project Descriptions	Budget	Schedule / Status (Calendar Year)	Location	Service Area
Parking Improvements (FY 2023 – 2026)				
Conshohocken Station Parking				
<p>In support of PennDOT’s I-76 Integrated Corridor Management (ICM) Program, this project provides for design, property acquisition, and construction of a multi-level smart parking facility. This project will increase available parking from 118 to 528 spaces. SEPTA is forecasted to receive \$10 million in Federal Highway Administration (FHWA) Congestion Mitigation and Air Quality (CMAQ) program dollars to support this project. Design was completed in 2022.</p>	\$48.33 M	Construction 2023 - 2026	Montgomery	Montgomery Philadelphia
<p>Due to reduced ridership resulting from the COVID-19 pandemic and as part of the Reimagining Regional Rail initiative, SEPTA is re-evaluating station parking needs. The following projects listed under the previous capital budget will be revisited in coordination with the results of Reimagining Regional Rail and as ridership returns and the need for parking at each location is clearer.</p>				
<ul style="list-style-type: none"> 69th Street Transportation Center Parking Garage Fern Rock Complex Gwynedd Valley Station Parking Ivy Ridge Parking Improvements Noble Station Parking Garage Philmont Station Parking Secane Station Parking 			Delaware Philadelphia Montgomery Philadelphia Montgomery Montgomery	Bucks Chester Delaware Montgomery Philadelphia

STATIONS, LOOPS AND PARKING IMPROVEMENTS

Project Descriptions	Budget	Schedule / Status (Calendar Year)	Location	Service Area
Transit Rail Station ADA Accessibility and Improvements Program (FY 2024 – 2035)				

City Hall & 15th Street Stations

Rehabilitation of City Hall Station on the Broad Street Line and 15th Street Station on the Market-Frankford Line (MFL) to make the stations fully ADA accessible; bring the stations to a state of good repair; improve customer use, safety and security; and reduce heavy maintenance costs. 15th Street Station rehabilitation was completed in 2020. The project will:

- Provide full access for riders with disabilities through installation of 14 new elevators and ramps to all levels of both stations, new and wider ramped corridors and accessible fare line gates;
- Improve passenger flow with reconfigured fare lines, wider stairs and railings, and more open areas on platforms and the 15th Street Mezzanine;
- Update station interiors and systems including new architectural finishes, signs, Art-in-Transit, lighting and public address systems, fire alarm system, closed-circuit TV and security systems;
- Provide structural repairs and upgrades, mechanical and natural ventilation and improvements to prevent/intercept water infiltration and inflow, new fire suppression systems and new employee restrooms.

The City Hall / 15th Street Stations project is being advanced in phases:

- Dilworth Park Phase and 15th Street Station (complete)
- Interlocking Reconfiguration: Modification of Fairmount interlocking to allow for track outages necessary to complete project construction and provide for greater future operational flexibility.
- Inter-Station Connections and City Hall Station structural work (underpinnings): New and widened corridors with ramps, improved ventilation structures, platform wall openings, and new elevator shaftways from the City Hall Station mezzanines to the platforms.
- City Hall Station: Upgrades within City Hall Station including fitting out the elevator shaftways with elevators and new or renovated platforms, stairs, lighting and amenities.

\$189.04 M

City Hall Station:
Design
2019 – 2023

Construction
2020 - 2029

Philadelphia

Philadelphia

STATIONS, LOOPS AND PARKING IMPROVEMENTS

Project Descriptions	Budget	Schedule / Status (Calendar Year)	Location	Service Area
Broad Street Subway Stations				

Design for Broad Street Subway Station ADA Accessibility

With funding programmed as part of the IIJA, SEPTA is initiating design of stations along the Broad Street Subway to advance construction as soon as operational needs allow. Design will be performed for the following station projects: Chinatown, Ellsworth-Federal, Fairmount Stations (Mainline and Broad-Ridge Spur), Hunting Park, Logan, Lombard-South, Snyder and Wyoming.

Commencing design now also allows SEPTA to pursue competitive funding that will be made available via the federal All Stations Accessibility Program (ASAP), a new program created by the Infrastructure Investment and Jobs Act (IIJA) that provides funding specifically for ADA Accessibility improvements at legacy rail stations.

\$12.00 M	Design 2022 - 2024	Philadelphia	Philadelphia
-----------	-----------------------	--------------	--------------

Chinatown Station on the Broad-Ridge Spur

Improvements to Chinatown Station on the Broad-Ridge Spur that will make the station fully ADA accessible. The project provides for the installation of elevators and accessibility improvements; renovation of existing platforms and station interior; new signage, lighting and security cameras; and waterproofing improvements. This project is being supported by an FTA All Stations Accessibility Program grant.

\$10.00 M	Construction 2025 - 2028	Philadelphia	Philadelphia
-----------	-----------------------------	--------------	--------------

STATIONS, LOOPS AND PARKING IMPROVEMENTS

Project Descriptions	Budget	Schedule / Status (Calendar Year)	Location	Service Area
<p>Ellsworth-Federal Station</p> <p>Improvements to Ellsworth-Federal Station on the Broad Street Line that will make the station fully ADA accessible. The project provides for the installation of elevators and accessibility improvements; renovation of existing platforms and station interior; new signage, lighting and security cameras; and waterproofing improvements.</p>	\$19.82 M	Construction 2029 - 2031	Philadelphia	Philadelphia
<p>Erie Station</p> <p>Improvements to the Erie station on the Broad Street Line that will make the station fully ADA accessible. Work includes installation of three (3) ADA accessible elevators with one being between street level and the mezzanine level of the station, and the other two being located within the paid areas of the mezzanine level and will serve the north and southbound platforms. The project will also provide for the construction of head houses for the elevator and station entrances at street level; new signage and lighting, security features including surveillance cameras, passenger amenities; and drainage and waterproofing improvements. This project is being supported by an FTA All Stations Accessibility Program grant.</p>	\$38.00 M	Design 2020 - 2023 Construction 2025 - 2027	Philadelphia	Philadelphia
<p>Fairmount Stations</p> <p>Improvements to Fairmount Station on the Broad Street Line and Broad-Ridge Spur to make both platform levels of the station fully ADA accessible. The project provides for installation of elevators and accessibility improvements; renovation of existing platforms and station interior; new signage, lighting and security cameras; and waterproofing improvements. This project is being supported by an FTA All Stations Accessibility Program grant.</p>	\$35.05 M	Construction 2024 - 2026	Philadelphia	Philadelphia

STATIONS, LOOPS AND PARKING IMPROVEMENTS

Project Descriptions	Budget	Schedule / Status (Calendar Year)	Location	Service Area
<p>Hunting Park Station</p> <p>Improvements to Hunting Park Station on the Broad Street Line that will make the station fully ADA accessible. The project provides for the installation of elevators and accessibility improvements; renovation of existing platforms and station interior; new signage, lighting and security cameras; and waterproofing improvements.</p>	\$24.76 M	Design 2022 - 2024 Construction 2028 - 2031	Philadelphia	Philadelphia
<p>Logan Station</p> <p>Improvements to Logan Station on the Broad Street Line that will make the station fully ADA accessible. The project provides for installation of elevators and accessibility improvements; renovation of existing platforms and station interior; new signage, lighting and security cameras; and waterproofing improvements.</p>	\$24.76 M	Construction 2029 - 2032	Philadelphia	Philadelphia
<p>Lombard-South Station</p> <p>Improvements to Lombard-South Station on the Broad Street Line that will make the station fully ADA accessible. The project provides for installation of elevators and accessibility improvements; renovation of existing platforms and station interior; new signage, lighting and security cameras; and waterproofing improvements.</p>	\$19.82 M	Construction 2029 - 2032	Philadelphia	Philadelphia
<p>Snyder Station</p> <p>Improvements to Snyder Station on the Broad Street Line that will make the station fully ADA accessible. The project provides for the installation of elevators and accessibility improvements; renovation of existing platforms and station interior; new signage, lighting and security cameras; and waterproofing improvements. This project is being supported by an FTA All Stations Accessibility Program (ASAP) grant.</p>	\$30.36 M	Construction 2024 - 2026	Philadelphia	Philadelphia

STATIONS, LOOPS AND PARKING IMPROVEMENTS

Project Descriptions	Budget	Schedule / Status (Calendar Year)	Location	Service Area
<p>Susquehanna-Dauphin Station</p> <p>Modernization of Susquehanna-Dauphin Station on the Broad Street Line to make the station fully ADA accessible. The project includes the installation of elevators; relocating the existing head house and replacing with a covered head house; accessible pathways and handrails/ guardrails; signage, lighting and security cameras.</p>	\$23.87 M	Construction 2020 - 2024	Philadelphia	Philadelphia
<p>Tasker-Morris Station</p> <p>Improvements to Tasker-Morris Station on the Broad Street Line that will make the station fully ADA accessible. The project provides for installation of elevators and accessibility improvements; renovation of existing platforms and station interior; new signage, lighting and security cameras; and waterproofing improvements.</p>	\$19.21 M	Construction 2022 - 2026	Philadelphia	Philadelphia
<p>Wyoming Station</p> <p>Improvements to Wyoming Station on the Broad Street Line that will make the station fully ADA accessible. The project provides for installation of elevators and accessibility improvements; renovation of existing platforms and station interior; new signage, lighting and security cameras; and waterproofing improvements.</p>	\$24.76 M	Construction 2029 - 2030	Philadelphia	Philadelphia

STATIONS, LOOPS AND PARKING IMPROVEMENTS

Project Descriptions	Budget	Schedule / Status (Calendar Year)	Location	Service Area
Market-Frankford Line Stations				
11th Street Station				
Improvements to 11th Street Station on the Market-Frankford Line that will make the station fully ADA accessible. The project provides for installation of elevators and accessibility improvements; renovation of existing platforms and station interior; new signage, lighting and security cameras; and waterproofing improvements. This project is being supported by an FTA All Stations Accessibility Program grant.	\$23.81 M	Design 2019 - 2023 Construction 2024 - 2027	Philadelphia	Philadelphia
34th Street Station				
Improvements to the 34th Street Station on the Market-Frankford Line that will make the station fully ADA accessible. The project provides for the installation of elevators and accessibility improvements; renovation of existing platforms and station interior; new signage, lighting and security cameras; and waterproofing improvements.	\$31.00 M	Design & Construction 2023 - 2028	Philadelphia	Philadelphia
Spring Garden Station				
Improvements to Spring Garden Station on the Market-Frankford Line that will make the station fully ADA accessible. The project provides for the installation of elevators and accessibility improvements; renovation of existing platforms; and new signage, lighting and security cameras. Work will be conducted concurrently with and in coordination with PennDOT's I-95 Improvement Project.	\$7.37 M	Design & Construction 2024 - 2028	Philadelphia	Philadelphia

STATIONS, LOOPS AND PARKING IMPROVEMENTS

Project Descriptions	Budget	Schedule / Status (Calendar Year)	Location	Service Area
----------------------	--------	--------------------------------------	----------	--------------

Norristown High Speed Line Stations

Bridgeport Station

As part of the rehabilitation of the Bridgeport Viaduct at Mile Post 12.81 (Schuylkill River) on the Norristown High Speed Line (NHSL), improvements will be made to Bridgeport Station to make the station fully ADA accessible. This project will also include rehabilitation of station facilities, including improvements to existing platforms and shelters, accessibility improvements including ramps and handrails/ guardrails, new signage, lighting and security cameras, and stormwater management.

\$4.00 M

Design & Construction
2024 - 2027

Montgomery

Delaware
Montgomery

Villanova Station

Improvements will make Villanova Station on the NHSL fully ADA accessible. Rehabilitation of station facilities, including improvements to existing platforms and shelters; accessibility improvements including ramps and handrails/ guardrails; new signage, lighting, and security cameras; and stormwater management.

\$4.00 M

Design & Construction
2023 - 2026

Delaware

Delaware
Montgomery

STATIONS, LOOPS AND PARKING IMPROVEMENTS

Project Descriptions	Budget	Schedule / Status (Calendar Year)	Location	Service Area
Regional Rail and Rail Transit Station ADA Accessibility and Improvements Program (FY 2029 – 2035)				
Stations programmed in FY 2028 - 2035 will be modernized and made ADA accessible. A detailed scope of work for these stations and additional Regional Rail and rail transit stations identified for capital improvements will be developed as they are designed. Stations include but are not limited to the following:				
• Devon Station on the Paoli/Thorndale Regional Rail Line	\$20.00 M	2029 - 2035 Project	Chester	
• East Falls Station on the Manayunk/Norristown Regional Rail Line	\$19.50 M	2029 - 2035 Project	Philadelphia	
• Glenside Station on Regional Rail Mainline	\$24.75 M	2029 - 2035 Project	Montgomery	
• Ivy Ridge Station on the Manayunk/Norristown Regional Rail Line	\$18.50 M	2029 - 2035 Project	Philadelphia	
• Wissahickon Station on the Manayunk/Norristown Regional Rail Line	\$28.20 M	2029 - 2035 Project	Philadelphia	
• Wyndmoor Station on the Chestnut Hill East Regional Rail Line	\$19.50 M	2029 - 2035 Project	Philadelphia	
• Wynnewood Station on the Paoli/Thorndale Regional Rail Line	\$19.50 M	2029 - 2035 Project	Montgomery	
• Other regional rail stations and Norristown High Speed Line: TBD	TBD	2029 - 2035 Project	TBD	

SUBSTATIONS AND POWER IMPROVEMENTS

Many of SEPTA’s railroad and transit substations have been in continuous operation since the 1920s and 1930s. In order to bring these substations up to modern standards of reliability and performance, they must be overhauled or replaced. These projects will replace existing equipment with modern indoor switchgear and state-of-the-art industry safety systems, communications and relay protection systems, and will provide additional power and reliability. Work includes replacing transformers, trolley breakers, feeder switches, substation switchgears and protective relaying.

Power infrastructure must also be brought to a state of good repair. This includes replacing catenary systems and upgrading 80+ year old Regional Rail infrastructure. Additional power improvements will be undertaken as part of the Infrastructure Safety Renewal Program (ISRP).



Portal Switching Station

Substations and Power Improvements - Program Elements (\$ Millions)	Prior Funding	FY 2024	FY 2025	FY 2026	FY 2027	FY 2028	FY 2029 - 2035	12-Year Program Total	Total Budget
Power	\$26.89	\$4.84	\$5.00	\$17.54	\$23.07	-	-	\$50.46	\$77.34
Substation	\$110.16	\$25.71	\$33.13	\$34.93	\$47.52	\$60.30	\$181.41	\$383.00	\$493.17
Substations and Power Improvements Total	\$137.05	\$30.55	\$38.13	\$52.47	\$70.59	\$60.30	\$181.41	\$433.46	\$570.51



12th Street Switching Station



30th Street West Catenary

SUBSTATIONS AND POWER IMPROVEMENTS

Project Descriptions	Budget	Schedule / Status (Calendar Year)	Location	Service Area
Multimodal Substation Overhaul Program (FY 2024 - 2028)				
Supervisory Control and Data Acquisition (SCADA) System and Network Upgrade				
<p>SEPTA’s expansive traction power infrastructure is monitored and controlled centrally from its Control Center through a complex Supervisory Control and Data Acquisition (SCADA) system. The SCADA system allows SEPTA’s dispatch personnel to continuously monitor and control traction power substation and wayside equipment throughout SEPTA’s City Transit, Suburban Transit, and Regional Rail Divisions. In addition to the traction power equipment, the SCADA system also monitors/controls primary lighting and signal circuits, pump rooms, intrusion and fire alarms, and various other points of indication/control.</p> <p>This project will replace an existing aged legacy SCADA system that is becoming increasingly difficult to maintain due to the obsolescence of critical components and supporting communication infrastructure. The project will modernize the system and control room to improve operational efficiencies and provide enhanced data for trending and analytics.</p>	\$18.50 M	Design & Implementation 2024 – 2028	System-wide	System-wide
Substation Design and Equipment Purchase				
<p>This program includes the design necessary for improvements to seven transit substations (Market, Ellen, Ranstead, Park, Broad, Loudon, and Castor), nine railroad substations and switching stations (Neshaminy, Bethayres, Yardley, Lansdale, Hatboro substations and 12th Street, 18th Street, and Portal switching stations), and one new substation at Woodbourne. The program also includes procuring long lead equipment such as auto transformers and circuit breakers that will be required for the substation construction projects.</p>	\$28.23 M	Design / Procurement 2016 – 2027	Bucks Montgomery Philadelphia	System-wide

SUBSTATIONS AND POWER IMPROVEMENTS

Project Descriptions	Budget	Schedule / Status (Calendar Year)	Location	Service Area
Power Improvements (FY 2023 - 2027)				
30th Street West Catenary Replacement				
Replacement and upgrade of the overhead contact system including catenary structures from 30th Street Station to 'K' Interlocking and the Powelton Yard Complex.	\$77.00 M	Design 2015 – 2023 Construction 2024 – 2027	Philadelphia	System-wide
Railroad Substations (FY 2024 - 2028)				
18th Street Switching Station				
Overhaul of 18th Street Switching Station in the Center City Tunnel. Work includes new transformers, trolley breakers, feeder breakers, substation switchgear and protective relaying. Design is being performed as part of the Substation Design and Equipment Purchase project (see description above).	\$13.00 M	Construction 2024 – 2027	Philadelphia	Network-wide
Brill Substation				
Replacement of major power components at Brill Substation, originally built in 1985, on the Airport Regional Rail Line. Work includes installing new transformers, trolley breakers, feeder breakers, substation switchgear and protective relaying.	\$12.80 M	Design & Construction 2026 – 2028	Philadelphia	Philadelphia

SUBSTATIONS AND POWER IMPROVEMENTS

Project Descriptions	Budget	Schedule / Status (Calendar Year)	Location	Service Area
Cresheim Valley Substation				
Construction of a new substation for the Chestnut Hill East and West Regional Rail Lines. Work includes new transformers, trolley breakers, feeder breakers, substation switchgear and protective relaying. The new Cresheim Valley substation will consolidate the functions of the existing Chestnut Hill East substation, Allen’s Lane switching station, and Amtrak’s North Philadelphia substation.	\$25.79 M	Design 2022 – 2024 Construction 2025 – 2027	Philadelphia	Bucks Chester Delaware Montgomery Philadelphia New Jersey
Wayne Junction Static Frequency Converters (SFC) #1-4				
The major components of the three Static Frequency Converters (SFCs), located adjacent to Wayne Junction Substation, are past their useful lives. SFCs are necessary to convert 230 kV 60 Hz power provided from PECO into a one-of-a-kind 24/12 kV 25 Hz auto transformer system. The construction of a new #4 converter must be completed before the replacement of the three existing converters is initiated to sustain existing service during construction. Design was completed in 2021.	\$101.72 M	Construction 2022 – 2028	Philadelphia	Bucks Montgomery Philadelphia
Woodbourne Substation				
Construction of a new Traction Power and Substation on the West Trenton Regional Rail Line. Design is being performed as part of the Substation Design and Equipment Purchase project (see description above).	\$23.79 M	Construction 2024 – 2027	Bucks	Bucks Montgomery Philadelphia

SUBSTATIONS AND POWER IMPROVEMENTS

Project Descriptions	Budget	Schedule / Status (Calendar Year)	Location	Service Area
Regional Rail Substations (FY 2028 – 2035)				
Regional Rail Substation Program				
Multi-year overhaul of other regional rail substations. Work includes installing new breakers, rectifiers, transformers, relays and switch gear.	\$36.00 M	2029 – 2035	Bucks Chester Delaware Montgomery Philadelphia	System-wide
Transit Substations (FY 2024 - 2029)				
Ellen Substation				
Overhaul of Ellen Substation, serving the Market-Frankford Line and a portion of the Rt. 15 Trolley. Work includes replacement and upgrade of existing breakers, rectifiers, transformers, relays and switch gears. Design is being performed as part of the Substation Design and Equipment Purchase project (see description above).	\$12.68 M	Construction 2026 – 2028	Philadelphia	Delaware Philadelphia
Market Substation				
Overhaul of the Market Substation, serving the Market-Frankford Line and City Trolley Lines. Work includes replacement and upgrade of existing breakers, rectifiers, transformers, relays and switch gears. Design is being performed as part of the Substation Design and Equipment Purchase project (see description above).	\$15.00 M	Construction 2024 – 2026	Philadelphia	Delaware Philadelphia

SUBSTATIONS AND POWER IMPROVEMENTS

Project Descriptions	Budget	Schedule / Status (Calendar Year)	Location	Service Area
Park, Broad, Loudon, Castor Substations				
<p>Overhaul of the following transit substations. Work includes replacement and upgrade of existing breakers, rectifiers, transformers, relays and switch gears.</p> <ul style="list-style-type: none"> • Park Substation, serving the Broad Street Line (BSS). • Broad Substation, serving the BSS and Ridge Avenue Spur. • Loudon Substation, serving the BSS and Route 75 Trackless Trolley. • Castor Substation, serving the Route 59 Trackless Trolley. <p>Design is being performed as part of the Substation Design and Equipment Purchase project (see description above).</p>	\$41.65 M	Construction 2024 – 2028	Philadelphia	Philadelphia
Ranstead Substation				
<p>Overhaul of Ranstead Substation, serving the Market-Frankford Line and a portion of the City and Suburban Trolley Lines. Work includes replacement and upgrade of existing breakers, rectifiers, transformers, relays and switch gears.</p> <p>Design is being performed as part of the Substation Design and Equipment Purchase project (see description above).</p>	\$12.68 M	Construction 2027 – 2029	Philadelphia	Philadelphia Delaware
Transit Substations (FY 2029 - 2035)				
Transit Substation Program				
<p>Multi-year overhaul of other transit substations. Work includes installing new breakers, rectifiers, transformers, relays and switch gear.</p>	\$140.00 M	2029 – 2035	Philadelphia	Philadelphia

TRACK AND RIGHT-OF-WAY IMPROVEMENTS

This program will provide for improvements to SEPTA’s track and right-of-way (ROW). SEPTA operates rail service over 605 route miles of track (including track owned by SEPTA, Amtrak, the City of Philadelphia, and CSX). Projects will return rail infrastructure to a state of good repair and help preserve rail transit service for current and future customers. This program includes projects on both the Transit and Regional Rail systems that will renew street track and special work, replace continuous welded rail (CWR), and renew ties and timbers. This program also focuses on the stabilization of soil and rock slopes, stormwater and erosion control, track drainage, and the repair and prevention of sinkholes in the right-of-way. Additional track and right-of-way improvements will be undertaken as part of the Infrastructure Safety Renewal Program (ISRP).

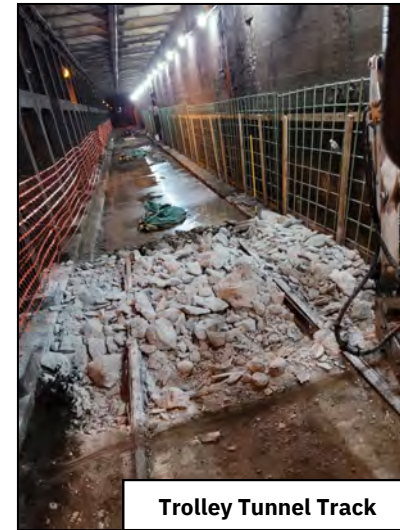

Trolley Tunnel Track

Track and Right-of-Way Improvements - Program Elements (\$ Millions)	Prior Funding	FY 2024	FY 2025	FY 2026	FY 2027	FY 2028	FY 2029 - 2035	12-Year Program Total	Total Budget
Regional Rail Track & ROW	\$11.85	\$12.50	\$7.33	\$5.00	\$15.00	\$15.00	-	\$54.83	\$66.68
Transit Track & ROW	\$56.73	\$7.92	\$3.44	\$4.38	\$2.61	\$2.50	\$17.52	\$38.38	\$95.11
Track and Right-of-Way Improvements Total	\$68.58	\$20.42	\$10.77	\$9.38	\$17.61	\$17.50	\$17.52	\$93.20	\$161.78

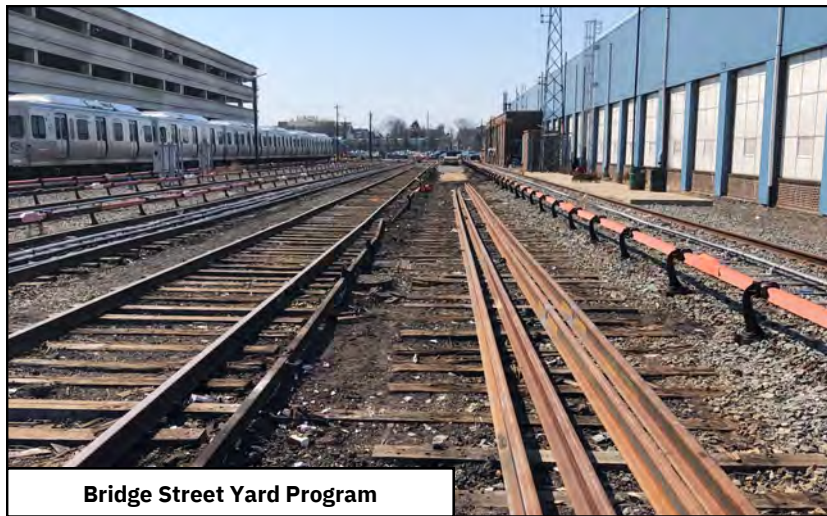

Bridge Street Yard Program



NHSL Tie Replacement & Continuous Welded Rail

TRACK AND RIGHT-OF-WAY IMPROVEMENTS

Project Descriptions	Budget	Schedule / Status (Calendar Year)	Location	Service Area
Railroad Track and Right-of-Way Improvements (FY 2024 – 2028)				
Harrisburg Line Capacity Improvements – Track 2				
The project will rehabilitate and upgrade Track 2 from Glen to Thorn Interlocking in Chester County, PA, on the Amtrak-owned Harrisburg Line between Philadelphia and Harrisburg. The Federal Railroad Administration (FRA) Federal-State Partnership Grant funded project will upgrade 10 miles of track to FRA class 3 standards (60 mph) and upgrade the signal system with bidirectional signals. This project is a joint effort of SEPTA, Amtrak, and PennDOT.	\$16.68 M	Construction 2021 - 2025	Philadelphia	Philadelphia Delaware
Norristown & Airport Line Freight Separation				
The project includes design & construction of new track segments along the Manayunk/Norristown Line and Airport Line to separate SEPTA regional rail services from freight rail operations. Separating from freight operations creates the opportunity for increased frequency on the Manayunk/Norristown & Airport Lines. As part of the project, the Norristown & Eastwick Regional Rail stations will be reconstructed and made fully ADA accessible.	\$50.00 M	Design & Construction 2023 - 2028	Montgomery Philadelphia	Montgomery Philadelphia
Transit Track and Right-of-Way Improvements (FY 2024 – 2027)				
Market-Frankford Line Bridge Street Yard Program				
Renewal of yard tracks including 3rd rail for the Market-Frankford Line at the Bridge Street Yard.	\$3.00 M	Construction 2021 - 2024	Philadelphia	Philadelphia Delaware

TRACK AND RIGHT-OF-WAY IMPROVEMENTS

Project Descriptions	Budget	Schedule / Status (Calendar Year)	Location	Service Area
<p>Norristown High Speed Line Tie Replacement and Continuous Welded Rail</p> <p>Renewal of ties and bridge timbers, and conversion of 100-pound bolted rail to 115-pound bolted rail for the Norristown High Speed Line (NHSL), including track surfacing, and new special track work. Project includes acquiring special rail maintenance of way (MOW) equipment including a tie handler, tie inserter/extractor, tamper, spiker, and spike puller. Design is complete.</p>	\$40.0 M	Construction 2014 - 2025	Delaware Montgomery	Delaware Montgomery
<p>Route 101/102 Yard Tracks Program</p> <p>Renewal of yard tracks and special track work for the Suburban Transit Division Route 101/102 Trolley Lines at the 69th Street maintenance complex. Design was completed in 2022.</p>	\$7.10 M	Construction 2023 - 2027	Delaware	Delaware
<p>Trolley Tunnel Track</p> <p>Annual program to renew track, ties, and curve worn rail in the City Transit Division Trolley Tunnel. The tunnel serves Trolley Routes 10, 11, 13, 34 and 36. This is an ongoing systemwide program to address critical needs to keep the SEPTA system operating reliably and safely.</p>	\$33.01 M	Ongoing	Philadelphia	Philadelphia
<p>Removal of Abandoned Trolley Tracks</p> <p>Annual program to remove abandoned trolley tracks no longer in service along City of Philadelphia streets to improve safety in the public right-of-way.</p>	\$12.00 M	Ongoing	Philadelphia	Philadelphia

VEHICLE ACQUISITIONS AND OVERHAULS

SEPTA utilizes a fleet of over 3,000 revenue vehicles and non-revenue vehicles that support revenue services and utility work. Under this Program of Projects, vehicles will be overhauled on a planned schedule to maintain a state of good repair throughout a vehicle's service life. This program also provides for the replacement of revenue and utility vehicles and equipment that have exceeded their useful life. As SEPTA continues to develop its Zero Emission Bus (ZEB) Playbook (<https://planning.septa.org/projects/zero-emission-bus/>), the authority is proceeding with a 3-year bus procurement to replace the final diesel powered buses with more efficient hybrid-electric vehicles. Future bus purchases beginning in FY 2027 will be guided by the results of Bus Revolution and the ZEB Playbook.



Work Train Locomotive Replacement

Vehicle Acquisitions and Overhauls - Program Elements (\$ Millions)	Prior Funding	FY 2024*	FY 2025*	FY 2026	FY 2027	FY 2028	FY 2029 - 2035	12-Year Program Total	Total Budget
Bus Purchase Program	\$226.50	\$110.92	\$24.18	\$0.00	\$108.19	\$111.43	\$870.94	\$1,225.65	\$1,452.15
Paratransit Vehicle Acquisition	\$5.00	\$5.15	\$8.50	\$9.66	\$7.82	\$8.33	\$56.00	\$95.46	\$100.46
Regional Rail Vehicle Acquisition	\$150.39	\$10.00	\$10.00	\$14.61	-	-	-	\$34.61	\$185.00
Utility Fleet Vehicle Acquisition	\$6.00	\$18.00	\$18.34	\$14.37	\$12.00	\$10.00	\$74.50	\$147.21	\$153.21
Vehicle Overhaul Program	\$158.68	\$62.65	\$40.37	\$96.55	\$94.66	\$93.00	\$651.00	\$1,038.23	\$1,196.90
Vehicle Acquisitions and Overhauls Total	\$546.56	\$206.71	\$101.39	\$135.19	\$222.66	\$227.77	\$1,652.44	\$2,541.16	\$3,087.72

* FY 2024 and FY 2025 Vehicle Overhaul Program budgets reflect fiscal year allocations. Forecasted Vehicle Overhaul Program cashflows for FYs 2024 and 2025 are \$113.84M and \$104.72M, respectively, supported by prior funding in the amount of \$115.54M.



SEPTA Transit Police Vehicle Replacement



Bus Purchase Program

VEHICLE ACQUISITIONS AND OVERHAULS

Project Descriptions	Budget	Schedule / Status (Calendar Year)	Location	Service Area
Bus Purchase Program (FY 2024 - 2035)				
<p>SEPTA is planning for a full transition to zero-emission buses (ZEBs) by the year 2040. The Zero Emission Bus (ZEB) Master Plan will lay the groundwork for the bus fleet of the future. SEPTA has completed the first phase of analysis that examines the feasibility of procuring battery electric buses (BEBs) and installing charging infrastructure to support the fleet. The next phase of the plan will evaluate fuel cell electric buses (FCEBs) and the necessary fueling infrastructure to support them.</p> <p>To ensure the reliability and continuity of bus operations while the ZEB Master Plan and transition plan is finalized, the Authority contracted with New Flyer to purchase 220 hybrid buses with an option for 120 additional buses, which SEPTA has executed. This bus procurement will allow SEPTA to retire the last of the 40-foot all-diesel fleet which is now more than 15 years old (purchased in 2005).</p> <p>Additionally, SEPTA was selected to receive an FTA Low or No Emission Vehicle Program grant for the purchase of 10 hydrogen fuel cell electric buses and the requisite fueling equipment. Procurement is underway and these vehicles, which will operate out of Midvale Depot, will be delivered in 2024. Future bus purchases will be guided by the ZEB Playbook and the results of Bus Revolution.</p>	<p>340 40-Ft. Hybrid Bus Purchase \$339.35 M</p> <p>10 Fuel Cell Electric Buses \$22.24</p> <p>Future Bus Purchases \$1,090.56 M</p>	<p>340 40-Ft. Hybrid Buses Delivery 2023 - 2025</p> <p>10 40-Ft. Fuel Cell Buses Delivery 2024</p> <p>Future Bus Purchases Procurement & Delivery 2027 - 2035</p>	<p>System-Wide</p>	<p>System-Wide</p>

VEHICLE ACQUISITIONS AND OVERHAULS

Project Descriptions	Budget	Schedule / Status (Calendar Year)	Location	Service Area
Paratransit Vehicle Purchase Program (FY 2024- 2035)				
<p>SEPTA routinely acquires new revenue vehicles for its paratransit and shared-ride services to replace vehicles that have exceeded their useful life of five years. These vehicles are provided to private carriers, which operate the services and maintain the vehicles under contract to SEPTA.</p> <p>SEPTA ownership of these vehicles provides the following benefits:</p> <ul style="list-style-type: none"> • The flexibility to rapidly exchange vehicles between carrier networks should the need arise • Creates an economic incentive for carriers to provide quality service • More control over fleet composition and standardization of the fleet • More control over vehicle design features. 	\$100.46 M	Ongoing	Bucks Chester Delaware Montgomery Philadelphia	Bucks Chester Delaware Montgomery Philadelphia
Regional Rail Multi-Level Car Acquisition (FY 2017 - 2025)				
<p>This project provides for the acquisition of new multi-level push-pull passenger railcars. In 2017, a contract was awarded to CRRC MA Corp. for 45 railcars with an option for an additional 10 push-pull railcars. The new cars will fully comply with Americans with Disabilities Act (ADA) requirements and federal and state regulations regarding safety features and systems. The cars will include passenger amenities, such as a state-of-the-art climate control system, bicycle storage area and Wi-Fi. The new cars will have electronic exterior and interior destination signs, voice annunciation and corresponding display on video screens of train destination and upcoming station stops. In addition, the new railcars will be equipped with on-board video surveillance and automatic passenger counting systems. The contract award is complete.</p>	\$185.00 M	Delivery 2024 - 2025	System-Wide	System-Wide

VEHICLE ACQUISITIONS AND OVERHAULS

Project Descriptions	Budget	Schedule / Status (Calendar Year)	Location	Service Area
Vehicle Overhaul Program (VOH) (FY 2024 - 2035)				
<p>SEPTA's Vehicle Overhaul Program (VOH) provides for the systematic replacement or upgrade of systems on SEPTA's rolling stock and VOH support equipment. In addition to vehicle fleet overhauls, this program also provides for vehicle campaigns to address specific component overhaul needs of a bus or rail fleet. The VOH Program allows SEPTA to continue its overhaul of rolling stock, thus ensuring continued safe and reliable service, particularly for its increasingly aging rail vehicle fleet.</p> <p>Vehicles are scheduled for overhauls during their service lives based on vehicle type and age to optimize performance throughout its useful service life. Prudent fleet management requires a program of preventive maintenance for optimal fleet reliability, service quality, efficient performance, and passenger comfort. Advanced scheduling of vehicle overhauls and campaigns allows SEPTA to purchase material and produce rebuilt components in an efficient and effective manner.</p> <p>Highlights of the Fiscal Year 2024 program includes the following activities:</p> <ul style="list-style-type: none"> • Bus Overhaul: 40-foot Nova hybrid buses, 60-foot Nova Articulated hybrid buses and prototypes for the midlife overhaul of New Flyer 40-foot Xcelsior hybrid and 30-foot MiDi Series fleets. • Rail Overhaul: Broad Street B-IV cars, City and Suburban trolleys, Regional Rail Silverliner IV and V cars, Regional Rail Push-Pull cars, Market Frankford M-4 cars, Route 15 PCC-II Trolley Cars, Norristown High Speed Line N-5 cars, and support vehicles and equipment. 	\$1,196.90 M	Annual program to overhaul portions of each vehicle fleet	System-Wide	System-Wide

VEHICLE ACQUISITIONS AND OVERHAULS

Project Descriptions	Budget	Schedule / Status (Calendar Year)	Location	Service Area
Utility Fleet Renewal (Non-Revenue Vehicles) (FY 2024 - 2035)				
<p>The Utility Fleet Renewal Program is a comprehensive effort to upgrade and replace the Authority’s utility fleet and automotive service fleet. SEPTA utility vehicles support transit and railroad operations. To have adequate and reliable utility vehicles, SEPTA has developed a program to periodically renew this fleet on a vehicle-by-vehicle basis, contingent upon the vehicle’s age, condition and usage within the Authority.</p> <p>The utility fleet comprises the following types of vehicles and equipment:</p> <ul style="list-style-type: none"> • Utility vehicles for transit and paratransit supervisors, and SEPTA police officers. • Maintenance-of-way vehicles used for inspection, maintenance and construction of buildings, overhead power systems, communications systems, signal systems and track. These vehicles include trucks, cranes, high rail vehicles and maintenance-of-way equipment. • Transporter vehicles used in garages and shops, including revenue trucks, forklifts for material handling, pick-up trucks for material movement between depots and shops, and for snow removal. • Service vehicles used for vehicle maintenance including wreckers, tow tractors, man lifts and pick-up trucks. • Miscellaneous equipment such as generators, compressors, trailers, floor scrubbers and welding units. 	\$153.21 M	Ongoing	System-Wide	System-Wide

APPENDIX A: BUDGET AND SCHEDULE CHANGES

The table below summarizes changes to project budgets and schedules between the approved Fiscal Year (FY) 2023 Capital Budget (FY 2023 - 2034) Capital Program and the proposed FY 2024 Capital Budget (FY 2024 - 2035) Capital Program.

Program	Project	FY 2023 Capital Program		FY 2024 Capital Program	
		FY2023 Budget	FY2023 Schedule	FY2024 Budget	FY2024 Schedule
Bridge Program	Chestnut Hill East Line Bridge Rehabilitation	\$30.00	Design and Construction 2022 - 2027	\$30.00	Design and Construction 2023 - 2028
	Chestnut Hill West Line Bridge	\$35.00	Design and Construction 2022 - 2028	\$35.00	Design and Construction 2023 - 2028
	Critical Bridge Program	\$164.19	Ongoing	\$172.84	Ongoing
	Mainline-Schuylkill Bridges Phase 1	\$10.95	Design and Construction 2021 - 2024	\$10.95	Complete
	Mainline-Schuylkill Bridges Phase 2	\$10.95	Design and Construction 2021 - 2024	\$10.95	Design and Construction 2021 - 2025
	Mainline-Schuylkill Bridges Phase 3	\$45.05	Design & Construction 2022 - 2028	\$45.05	Design 2023 - 2025; Construction 2029 - 2032
	Stone Arch Bridge Program - Phase 2	\$13.20	Design 2017 - 2020 Construction 2020 - 2026	\$13.20	Construction 2020 - 2025
	NHSL Bridge 0.15 over 69th St. Yard Tracks	\$4.00	Construction 2018 - 2023	\$4.00	Construction 2018 - 2024
	NHSL Viaduct over Schuylkill River	\$35.00	Design 2022 Construction 2023 - 2026	\$35.00	Design 2022 - 2024 Construction 2024 - 2027
	Suburban Rail Transit Critical Bridge	\$29.85	Ongoing	\$29.82	Ongoing
Communications, Signal Systems & Technology	Broad Street Line Ridge-Spur Signals	\$14.66	Design & Construction 2015 - 2023	\$14.66	Design and Construction 2015 - 2024
	Broad Street Line Signals	\$65.00	Design & Construction 2028 - 2034	\$65.00	Design & Construction 2029 - 2035
	Computer Aided Radio Dispatch (CARD) System Replacement	\$124.82	Design Complete; Construction 2022 - 2026	\$124.82	Design Complete; Construction 2022 - 2028
	Control Center Wall Display	\$6.39	Design Complete; Construction 2021 - 2023	\$6.39	Design Complete; Construction 2021 - 2024
	Fare Payment Technology Upgrade Design	\$5.00	Design 2022 - 2024		
	Information Technology Program	\$134.32	Ongoing	\$267.08	Ongoing
	Interlocking Improvement Program (RRD)	\$183.96	Ongoing	\$214.02	Ongoing
	Positive Train Control	\$174.02	Construction 2012 - 2021; Continuing Integration with Partner Railroads 2021 - 2023	\$174.02	Construction 2012 - 2021; Continuing Integration with Partner Railroads 2021 - 2026
	Norristown High Speed Line Interlockings	\$12.27	Construction 2018 - 2024	\$12.27	Design and Construction 2018 - 2024
	Real-Time Information / Audio Visual Public Address (AVPA)	\$34.73	Implementation 2017 - 2024	\$34.73	Implementation 2017 - 2026
	Regional Rail Signal Upgrades Program	\$40.00	2031 - 2034 & Beyond Project	\$40.00	2029- 2035 Project
	Regional Rail VHF Radio Upgrade			\$57.00	Design and Construction 2024 - 2029
	Route 101/102 Positive Train Control & ROW Improvements	\$90.12	Construction 2015 - 2023	\$95.00	Construction 2015 - 2024
	Southwest Connection (30th to Phil Signals, Catenary & ROW)	\$57.99	Construction 2017 - 2022	\$57.99	Construction 2017 - 2024
	Fare Evasion Pilot Program			\$0.99	Design and Construction 2023 - 2024
	Trolley Signal Systems	N/A	Part of Trolley Modernization		
	Video Systems Refreshment Program	\$42.37	Implementation 2023 - 2034	\$42.37	Ongoing
	PTC - Onboard Survey Mapping / ACCESS III	\$3.30	Development 2021-2024	\$3.30	Development 2021 - 2025
	Market-Frankford Line PTC (Preliminary Engineering)	\$82.00	Preliminary Design 2022 - 2028	\$82.00	Design 2024 - 2025; Construction 2026 - 2030
	Harrisburg Line Capacity Improvements - Bidirectional Signaling - Paoli to Overbrook	\$21.90	Design and Construction 2022 - 2029	\$21.91	Design and Construction 2022 - 2028
	SEPTA Transformation - Efficiency and Accountability Capital Support	\$1.90	Design & Implementation 2022 - 2024	\$2.50	Design & Implementation 2022 - 2024
	Signal System Renewal on the Norristown High Speed Line	\$80.00	Design 2022 - 2023; Construction 2023 - 2030	\$80.00	Design 2023 - 2025; Construction 2026 - 2030
	Supervisory Control and Data Acquisition (SCADA) System and Network Upgrade	\$18.40	Design and Implementation 2028 - 2034	\$18.50	Design and Implementation 2024 - 2028
	Transit Asset Management System	\$6.77	Design and Implementation 2011 - 2023	\$6.77	Design and Implementation 2011 - 2024
	Zero Eyes			\$2.50	Implementation 2023 - 2025
	Key System Network Communication Hardware			\$6.00	Design and Construction 2023 - 2025
	Fare Box Replacement			\$22.00	Design and Construction 2023 - 2025

APPENDIX A: BUDGET AND SCHEDULE CHANGES

Program	Project	FY 2023 Capital Program		FY 2024 Capital Program	
		FY2023 Budget	FY2023 Schedule	FY2024 Budget	FY2024 Schedule
Financial Obligations	Capital Asset Leases	\$859.02	Ongoing	\$916.61	Ongoing
	Debt Service	\$8,244.01	Ongoing	\$1,526.25	Ongoing
ISRP	Infrastructure Safety Renewal Program	\$52.00	Ongoing	\$810.90	Ongoing
Maintenance/Transportation Shops and Offices	Environmental Clean Up and Protection	\$24.60	Ongoing	\$15.27	Ongoing
	Facilities Critical Infrastructure Program	\$43.00	Ongoing	\$62.30	Ongoing
	Facilities Furnishings Program			\$7.00	Ongoing
	Frazer Rail Shop and Yard Expansion	\$139.00	Design 2016 - 2021; P1&P2 Complete; P3 Construction 2022 - 2026	\$139.00	Phase 3 Construction 2022 - 2025
	Frazer Transportation Building	\$25.00	Design 2019 - 2022; Construction 2025 - 2030	\$25.00	Design 2023 - 2025; Construction 2026 - 2028
	Garage / Shop Overhead Doors	\$7.50	Design and Construction 2025 - 2034	\$7.00	Design and Construction 2029 - 2035
	Maintenance Facilities Improvement	\$55.00	2028 - 2034 Project	\$35.00	Evaluation & Implementation 2029 - 2035
	Maintenance Shop Equipment Program	\$61.00	Ongoing	\$51.49	Ongoing
	Midvale Dyno			\$0.31	Implementation 2024
	Powelton Yard Facility Improvements	\$5.53	Design Complete; Construction 2021 - 2023	\$5.53	Design Complete; Construction 2021 - 2024
	Steel Wheel Lift Program	\$12.32	Design and Construction 2023 - 2034	\$12.32	Design and Construction 2023 - 2029
	Vehicle Washer Program	\$20.00	Design and Construction 2023 - 2034	\$20.00	Design and Construction 2024 - 2033
	Wayne Car Shop Improvements	N/A	N/A		
	Wheel Truing Program Phase 1	\$10.51	Design and Construction 2023 - 2034	\$10.51	Design and Construction 2024 - 2028
	Wyoming Complex Stormwater Retrofits	\$8.36	Design 2020 - 2021; Construction 2022 - 2024	\$13.35	Design 2020 - 2021; Construction 2022 - 2025
	Boiler Replacement Program - Phase 2	\$16.00	Design & Construction 2027 - 2034	\$5.65	Design & Construction 2024 - 2035
	Bus Lift Program	\$8.00	Design & Construction 2027 - 2034	\$5.65	Design & Construction 2024 - 2035
	Courtland Facility (formerly Track Shop Facility)	\$22.50	Design 2018 - 2022; Construction 2023 - 2025	\$22.50	Design 2018 - 2023; Construction 2024 - 2026
	Victory Shop & Storage Phase 2	\$18.75	Design 2023 - 2024; Construction 2024 - 2030	\$18.75	Design 2024; Construction 2025 - 2027
	1234 Market Street Headquarters Improvements			\$10.00	Design and Construction 2024 - 2032
Zero Emission Bus (ZEB) Fleet Transition Facility Upgrades			\$50.00	Design 2024 - 2025; Construction 2026 - 2028	
Roof Program	69th St. Transportation Center Shop Complex Roofs Replacement	\$14.10	Construction 2016 - 2023		
	Frankford Depot Roof Replacement	\$8.80	Design 2023; Construction 2024 - 2026	\$18.80	Design 2023 - 2024; Construction 2024 - 2026
	Midvale Bus Garage Roof Replacement	\$29.90	Design Complete; Construction 2020 - 2023	\$29.90	Construction 2020 - 2024
	Southern Garage Roof Replacement	\$7.58	Design & Construction 2026 - 2029	\$13.00	Design & Construction 2027 - 2030

APPENDIX A: BUDGET AND SCHEDULE CHANGES

Program	Project	FY 2023 Capital Program		FY 2024 Capital Program	
		FY2023 Budget	FY2023 Schedule	FY2024 Budget	FY2024 Schedule
Projects of Significance	Bus Network Enhancement Projects	\$105.00	Design and Construction 2022 - 2034	\$91.13	Property Acquisition, Design and Construction 2022 - 2035
	Exton Station Multimodal Improvements	\$6.00	Design & Construction 2022 - 2024	\$6.00	Design & Construction 2023 - 2026
	40th Street Portal Construction			\$25.00	Design & Construction 2026 - 2028
	Market-Frankford Line Vehicle Replacement	\$720.00	MFL Vehicle Design 2021 - 2022; Rail Vehicle Acquisition 2023 - 2031	\$950.00	MFL Vehicle Design 2021 - 2022; Rail Vehicle Acquisition 2025 - 2031; Design 2024 - 2025; Construction 2026 - 2030
	Micro Transit Service Implementation			\$6.11	Vehicle Acquisition & Implementation 2025 - 2026
	Regional Rail Silverliner IV Replacements	\$92.57	2027 - 2033 Project	\$650.00	Implementation 2028 - 2034
	Regional Rail Master Plan Implementation			\$3.00	Implementation 2024 - 2028
	South Philadelphia Transportation Center	\$12.25	Design & Construction 2022 - 2026	\$12.25	Property Acquisition, Design & Construction 2023 - 2027
	Trolley Modernization	\$1,800	Design & Initial Enhancements 2021 - 2025; Trolley Acquisition 2027 - 2033; Construction 2021 - 2029	\$2,250.00	Trolley Acquisition 2023 - 2030; Design & Construction 2023 - 2035
Safety & Security	Fern Rock Transportation Center Pedestrian Access			\$25.00	Design 2024 - 2025 Construction 2033 - 2035
	Fern Rock Transportation Center Safety Improvements	\$20.52	Design 2018 - 2022; Construction 2019 - 2024	\$17.26	Design 2018 - 2022; Construction 2019 - 2025
	Escalator / Elevator Improvement Program	\$74.70	Ongoing	\$76.00	Ongoing
	Grade Crossing Enhancement Program	\$22.17	Ongoing	\$20.82	Ongoing
	Lawndale Station Pedestrian Underpass & High Level Platform	N/A	N/A	\$22.00	Design and Construction 2017 - 2026
	NHSL Slope Stabilization at Rebel Hill			\$22.00	Design and Construction 2025 - 2028
	Regional Rail Grade Crossing			\$22.00	Design and Construction 2023 - 2028
	Railroad Signal Power Reinforcement	\$43.23	Design Complete ; Construction 2019 - 2024	\$43.23	Design Complete ; Construction 2019 - 2025
	Safety and Security Infrastructure Hardening Program	\$50.44	Ongoing	\$50.00	Ongoing
	Safety and Security Shop, Yard, and Office	\$42.44	Ongoing	\$40.00	Ongoing
	Sharon Hill Line Flood Mitigation	\$15.37	Design Complete; Construction 2018 - 2023	\$15.37	Design Complete; Construction 2018 - 2024
	Station Ventilation Improvements: NRG	\$10.00	2028 - 2034 Project	\$10.00	Phase 1 Complete; Phase 2 2034 - 2035
	On-Site Power for Major Facilities	\$6.00	2028 - 2034 Project	\$5.00	Implementation 2030 - 2035
	Safety & Security Technology Upgrades	\$30.00	Ongoing	\$20.00	Implementation 2033 - 2035
Transit Security Grant Projects	\$12.00	Ongoing	\$13.38	Ongoing	
SEPTA Key	SEPTA Key 2.0 (New Payment Technology)			\$240.24	Implementation 2024 - 2030
Service Restoration	Elwyn to Middletown/US Route 1 Rail	\$197.21	Design Complete; Construction 2018 - 2022	N/A	N/A
	Coatesville Service Restoration	\$0.00		\$2.00	Design and Construction 2024 - 2025

APPENDIX A: BUDGET AND SCHEDULE CHANGES

Program	Project	FY 2023 Capital Program		FY 2024 Capital Program	
		FY2023 Budget	FY2023 Schedule	FY2024 Budget	FY2024 Schedule
Stations, Loops, & Parking	11th Street Station	\$23.81	Design 2019 - 2022; Construction 2022 - 2025	\$23.81	Design 2019 - 2023; Construction 2024 - 2027
	30th Street Station (MFL) - Phase A			\$24.80	
	30th Street Station (MFL) - Phase B			\$49.30	
	34th Street Station	\$31.00	Design & Construction 2022 - 2025	\$31.00	Design & Construction 2023 - 2028
	ADA Bridge Plates	\$2.21	Design & Procurement 2020 - 2023	\$4.40	Design & Procurement 2020 - 2024
	Ardmore Transportation Center Phase 1	\$53.60	Construction 2019 - 2023	\$53.60	Construction 2019 - 2024
	Ardmore Transportation Center Phase 2	\$26.05	TBD	TBD	TBD
	Bicycle Transit Access Program	\$2.26	Ongoing	\$2.50	Ongoing to 2033
	Bridgeport Station (NHSL)	\$4.00	Design and Construction 2022 - 2025	\$4.00	Design and Construction 2024 - 2027
	Broad Street Station ADA Accessibility	\$12.48	Design 2023 - 2025	\$12.00	Design 2022 - 2024
	Center City Concourses	\$59.65	P 2 & 4 Design 2020 - 2021; Construction 2021 - 2024; P 5 8 Design & Construction 2024 - 2029	\$59.65	P 2 & 4 Design 2020 - 2023; Construction 2021 - 2024; P 5 Design Complete Construction 2023 - 2024; P 6 - 8 Design & Construction 2024 - 2030
	Chinatown Station	\$10.00	Design 2022 - 2023; Construction 2025 - 2028	\$10.00	Construction 2025 - 2028
	Conshohocken Station	\$15.00	Design Complete; Construction 2020 - 2024	\$15.92	Design Complete; Construction 2020 - 2025
	Conshohocken Station Parking	\$38.22	Design 2020 - 2022; Construction 2022 - 2025	\$48.33	Design 2020 - 2022; Construction 2023 - 2026
	Cornwells Heights Station Reconfiguration			\$61.00	Design 2024 - 2025 Construction 2032 - 2035
	Devon Station	\$20.00	2028 - 2034 Project	\$20.00	2029 - 2035 Project
	East Falls Station	\$19.50	2028 - 2034 Project	\$19.50	2029 - 2035 Project
	Ellsworth-Federal Station	\$19.82	Design 2022 - 2024; Construction 2029 - 2031	\$19.82	Construction 2029 - 2031
	Erie Station	\$23.27	Design 2020 - 2022; Construction 2023 - 2025	\$38.00	Design 2020 - 2023; Construction 2025 - 2027
	Fairmount Station	\$35.05	Design 2020 - 2024; Construction 2025 - 2028	\$35.05	Construction 2024 - 2026
	Glenside Station	\$24.75	2028 - 2034 Project	\$24.75	2029 - 2035 Project
	Hunting Park Station	\$24.76	Design 2022 - 2024; Construction 2027 - 2030	\$24.76	Design 2022 - 2024; Construction 2028 - 2031
	Ivy Ridge Station	\$18.50	2028 - 2034 Project	\$18.50	2029 - 2035 Project
	Jenkintown-Wyncote Station	\$50.28	Design 2016 - 2023; Construction 2023 - 2026	\$50.28	Design 2016 - 2024; Construction 2024 - 2029
	Logan Station	\$24.76	Design 2026 - 2027; Construction 2028 - 2030	\$24.76	Construction 2029 - 2032
	Lombard-South Station	\$19.82	Design 2022 - 2024; Construction 2029 - 2032	\$19.82	Construction 2029 - 2032
	Malvern Station High Level Platforms	\$15.26	Design 2022 - 2024; Construction 2026 - 2027	\$15.26	Design 2023 - 2025; Construction 2026 - 2028
	Marcus Hook Station	\$22.50	Design 2022 - 2024; Construction 2029 - 2030	\$22.50	Design 2023 - 2025; Construction 2027 - 2029
	Noble Station on West Trenton Line	\$28.20	Design 2016 - 2023; Construction 2027 - 2031	\$28.20	Phase 1 Design Complete; Construction 2023 - 2025; Phase 2 Design 2023 - 2024; Construction 2026 - 2029
	Paoli Intermodal Transportation Center Phase 2	\$50.28	Design & Construction 2028 - 2034 Project Phase 3 TBD	\$50.28	Design & Construction 2029 - 2035
	Rail Transit Station ADA Stations	\$75.00	2032 - 2034 & Beyond Project		
	Rail Transit Wayfinding Signage	\$40.00	Design & Implementation 2021 - 2025	\$40.00	Design & Implementation 2021 - 2026
	Regional Rail Station Roof Program	\$12.00	Ongoing	\$13.06	Ongoing
	Roslyn Station	\$6.50	2028 - 2034 Project		
	Snyder Station	\$30.36	Design 2022 - 2024; Construction 2025 - 2026	\$30.36	Construction 2024 - 2026
	Spring Garden Station MFL	\$7.37	Design & Construction 2024 - 2026	\$7.37	Design & Construction 2024 - 2028
	Stenton Station	\$7.15	2028 - 2034 Project		

APPENDIX A: BUDGET AND SCHEDULE CHANGES

Program	Project	FY 2023 Capital Program		FY 2024 Capital Program	
		FY2023 Budget	FY2023 Schedule	FY2024 Budget	FY2024 Schedule
Stations, Loops, & Parking	Susquehanna-Dauphin Station	\$23.87	Construction 2020 - 2023	\$23.87	Construction 2020 - 2024
	Tasker-Morris Station	\$19.21	Design Complete; Construction 2022 - 2023	\$19.21	Design Complete; Construction 2022 - 2026
	Villanova Station NHSL	\$4.00	Design & Construction 2022 - 2025	\$4.00	Design & Construction 2023 - 2026
	Willow Grove Station	\$39.44	Phase 1 2017 - 2023; Phase 2 2024 - 2033 Project	\$44.00	Phase 1 Construction 2017 - 2023; Phase 2 Construction 2024 - 2029
	Wissahickon Station	\$28.20	2028 - 2034 Project	\$28.20	2029 - 2035 Project
	Wissahickon Transportation Center	\$37.64	Design Complete; Construction 2021 - 2025	\$45.16	Design Complete; Construction 2023 - 2025
	Wyndmoor Station	\$19.50	2028 - 2034 Project	\$19.50	2029 - 2035 Project
	Wynnewood Station	\$19.50	2028 - 2034 Project	\$19.50	2029 - 2035 Project
	Wyoming Station	\$24.76	Design 2022 - 2024; Construction 2027 - 2029	\$24.76	Construction 2029 - 2030
	Regional Rail and Norristown High Speed Line Stations			TBD	2029 - 2035 Project
Substations & Power	30th Street West Catenary Replacement	\$77.00	Design 2015 - 2023; Construction 2023 - 2027	\$77.00	Design 2015 - 2023; Construction 2024 - 2027
	Substation Design and Equipment Purchase	\$28.23	Design / Procurement 2016 - 2024	\$28.23	Design / Procurement 2016 - 2027
	Railroad Substation - 18th Street Switching Station	\$13.00	Construction 2023 - 2025	\$13.00	Construction 2024 - 2027
	Railroad Substation - Brill Substation	\$12.80	Design & Construction 2024 - 2028	\$12.80	Design & Construction 2026 - 2028
	Railroad Substation - Cresheim Valley Substation	\$25.79	Design & Construction 2022 - 2026	\$25.79	Design 2022 - 2024 Construction 2025 - 2027
	Railroad Substation - Lansdale, Hatboro and 12th Street/Portal Switching Stations	\$31.54	Construction 2019 - 2022		
	Railroad Substation - Woodbourne	\$23.79	Construction 2022 - 2026	\$23.79	Construction 2024 - 2027
	Regional Rail Substation Program	\$36.61	2032 - 2034 & Beyond Project	\$36.00	2029 - 2035 & Beyond Project
	Transit Substation - Ellen	\$12.68	Construction 2025 - 2028	\$12.68	Construction 2026 - 2028
	Transit Substation -Market	\$12.50	Construction 2022 - 2024	\$15.00	Construction 2024 - 2026
	Transit Substation - Park, Broad, Loudon, Castor Substations	\$19.95	Construction 2022 - 2024	\$41.65	Construction 2024 - 2028
	Transit Substation Program	\$140.00	2028 - 2034 & Beyond Project	\$140.00	2029 - 2035 & Beyond Project
Wayne Junction Static Frequency Converters (SFC) #1-4	\$85.70	Design 2015 - 2021; Construction 2022 - 2027	\$101.72	Design 2015 - 2021; Construction 2022 - 2028	
Track & ROW Improvements	Harrisburg Line Capacity Improvements - Track 2	\$16.68	Design & Construction 2021 - 2023	\$16.68	Construction 2021 - 2025
	Market-Frankford Line Bridge Street Yard Program	\$3.00	Design and Construction 2021 - 2023	\$3.00	Design and Construction 2021 - 2024
	Norristown High Speed Line Tie Replacement and Continuous Welded Rail	\$33.60	Construction 2014 - 2023	\$40.00	Construction 2014 - 2025
	Norristown Station Regional Rail & Airport Line Freight Separation	\$34.50	2028 - 2034 & Beyond Project	\$50.00	Design and Construction 2023 - 2028
	Remove Abandoned Trolley Tracks			\$12.00	Ongoing
	Route 101/102 Yard Tracks Program	\$7.10	Design & Construction 2021 - 2024	\$7.10	Design 2021 - 2022 Construction 2023 - 2027
	Transit Track and Right of Way Improvements	\$18.00	2026 - 2034 Project		
	Trolley Tunnel Track	\$42.80	Purchase & Delivery 2022 - 2024; Future Procurement & Delivery 2024 - 2033	\$33.01	Ongoing
Vehicle Acquisitions & Overhauls	Automatic Passenger Counters (APCs)	N/A	N/A		
	Bus Purchase Program	\$1,287.24	Ongoing	\$1,452.15	340 40' hybrid Delivery 2023 - 2025; 10 40' Fuel Cell Delivery 2024; Future Procurement & Delivery 2027 - 2035
	Paratransit Vehicle Purchase	\$102.50	Ongoing	\$100.46	Ongoing
	Regional Rail Electric Locomotive Acquisition	\$250.00	2028 - 2034 Project	\$252.00	2028 - 2034 Project
	Regional Rail Multi-Level Car Acquisition	\$180.00	Delivery 2022 - 2025	\$185.00	Delivery 2024 - 2025
	Utility Fleet Renewal	\$145.36	Ongoing	\$153.21	Ongoing
	Vehicle Overhaul Program	\$1,011.84	Ongoing	\$1,196.90	Ongoing